









# RADIO TELEPHONY

FOR

# AMATEURS

BY  
STUART BALLANTINE

CONSULTING ENGINEER AND FORMERLY EXPERT RADIO AID, UNITED STATES NAVY



PHILADELPHIA  
DAVID McKAY COMPANY, PUBLISHERS

TK6550  
B3

504606

Copyright, 1922, by  
DAVID MCKAY COMPANY

70 5151  
ANNONIAO



# CONTENTS

---

CHAPTER	PAGE
I. PRINCIPLES OF RADIO TELEPHONY.....	11
II. THE AUDION.....	44
III. ANTENNA CONSTRUCTION.....	58
IV. CONSTRUCTION AND OPERATION OF THE TRANSMITTER.....	96
V. SOURCES OF POWER.....	156
VI. RECEIVING APPARATUS.....	191
APPENDIX	
A. UNDERWRITERS' SPECIFICATIONS GOVERNING INSTALLATION OF RECEIVING ANTENNÆ.....	281
B. RADIO CLUBS. THE AMERICAN RADIO RELAY LEAGUE.....	284
<hr/>	
INDEX.....	289

## ERRATUM

Due to an unfortunate choice of words, the statement on page 91 (Art. 37) relative to the amount of resistance to be employed with the Beverage receiving antenna, may easily be construed to mean that the surge impedance of a line 10 feet high of No. 16 A. W. G. copper wire at high frequencies, is from 200-600 ohms. There is fortunately no such uncertainty about the surge impedance of a line of these dimensions, 550 ohms being the correct value. The range, 200-600 ohms, is indicated to allow for effects which the simple theory, giving the correct resistance as approximately equal to the surge impedance does not embrace.

## PREFACE

---

Truly "of the making of many books there is no end" and in view of the large number of radio books already existant and advertised as in the process of preparation or printing, perhaps some justification is necessary for the appearance of another. My *apologia* is a simple one, and possibly one engendered by ideas and aspirations not unfamiliar to all other radio amateurs. Since connecting up my first receiving apparatus in 1908 I have longed for the appearance of a certain type of radio book; a book issuing preferably from the pen of an amateur, radiating the true amateur spirit of inquest and investigation, a book chock-full of practical information and suggestions for new things to do and instructions for going about it, in a word, a book which would at once ignite the spark of my enthusiasm and furnish the material for its combustion. Such a book has never appeared, nor ever shall for the great majority of us, for we have all our own ideas as to what the ideal radio book for amateurs should be like. But intercourse extending over a number of years with kindred spirits and frequent discussions with them on this subject has induced the belief that in the main our ideas converge in a common channel. This book represents my conception of the direction and breadth of this channel.

I have always looked upon the book-making business with a great deal of fear and hesitation, clearly recognizing

the seriousness of addressing such a vast audience and the power of the pen for the dissemination of good or evil information. Particularly is this true of a book of this nature, whose readers are for the most part non-technical and in no position to judge the theoretical soundness of the suggestions and methods exploited, yet who are at the same time full of enthusiasm and ready to spend time and money upon almost any suggestion offered. My original plan therefore was to defer the book-writing for the growth of a few gray hairs, but this plan has aborted due to the encouragement of friends, the interest of the publishers, and my own feeling that in view of the present widespread popular enthusiasm a more auspicious time for publication will probably never arrive.

With elementary treatments of the theory of radio communication on the one hand, and with systematic engineering texts on the other, my book obviously enters into no competition. It is addressed mainly and first of all to the amateur; to the *amateur* in both the commonly accepted meaning of the word and in the true French sense of a lover, or admirer. This latter may be regarded as the legitimate amateur; a serious-minded individual with perhaps some technical propensities. My primary aim has been to include a maximum amount of practical information between its covers; secondarily to furnish an elementary theoretical web for this information, and to indicate in detail consistent with its restricted scope, the reasons for the suggestions and recommendations that have been made. No discussions of the "wonderfulness" of radio will be found, these being regarded as quite valueless and already furnished in super-sufficient quantity (considering the intelligence and imagina-

tion of the average individual), in radio books more obviously designed for exploitation on a favorable market. I have preferred to deal with hard facts rather than with such soft fancies.

In a book of restricted theoretical scope it is very hard to avoid a certain looseness of expression, and a considerable sacrifice of accuracy is sometimes necessary in order to leave the real issue free from obscurity. To take an example, on page 161 will be found a statement that the temperature of the audion filament is proportional to the rate at which heat is developed by the electric current, and I can picture in my mind a dozen academic purists and super-sophisticated electricians rising and scornfully tossing the book into a corner, molested by thoughts of the changing specific heats at high temperatures, the Stefan-Boltzman radiation law, heat of vaporization of the electrons, and a myriad other technical objections to this simple statement, the modification of which would not only be the rankest and most offensive kind of pedantry, but would also obscure the real point to be emphasized. I have also avoided mathematical formulæ, not because I did not feel that many of the arguments could have been considerably illumined by their use, but because I preferred to use the formulæ myself and state the results concisely in wire sizes, number of turns, and other terms of greater meaning to the average amateur. Most of the designs and specifications for construction rest upon such calculations, and in most cases I have at one time or other verified their correctness by experimental test. I have also had no hesitancy in making use of the results and experiences of others, as the references in the footnotes and the acknowledgements at the end of this foreword will show.

The first two chapters undertake an exposition of the fundamental principles of radio communication, particularly as applied in the present-day carrier-wave system of radio telephony. While I have had the beginner in mind and have endeavored to present this in a clear and understandable manner, yet lack of space prevents a detailed treatment of the elementary electrical theory a knowledge of which is desirable for the best comprehension of the more difficult theory of radio communication and the complicated electrical processes in the radio circuits. The reader who finds his interest in these matters stimulated is urged to consult works devoted to them, of which the best in the language are that admirable little book of Prof. J. J. Thomson's, *The Elements of the Mathematical Theory of Electricity and Magnetism* (Cambridge University Press); and another dealing more particularly with radio theory and no less carefully prepared and written by a staff of experts of the Bureau of Standards, *Principles Underlying Radio Communication*, copies of which latter may be obtained from the Supt. of Documents, Government Printing Office, Washington, D. C., for a dollar.

In the third and succeeding chapters all mistaken attempts at a popular treatment have been frankly abandoned. This I felt was necessary in order to get something said and to avoid the repetition of much subject matter adequately covered in other books. But the practical man will have no trouble, I think, in following the discussion, since the statements are explicit and to the point. I have tried to avoid the expression of opinions which are not defensible by rigid mathematical and experimental tests, and on controversial matters, feeling that in view of the advanced stage

to which the experimental technic has advanced and the rational theory which is now available respecting many of the radio-electrical processes (except radiation and propagation over the earth's surface) there is no excuse nor room in radio for differences of opinion. A number of pernicious and prevalent fallacies I have tried to expose and condemn and I hope the reader will overlook the impassioned way in which in many cases I have gone about it. Strong and forceful language is necessary when one is not gifted with the power of lucid expression.

While the preparation of this book may be said to date back to 1908 the actual writing was undertaken on short notice and I have not had the opportunity to look into the literature of amateur radio to the extent that I should desire, or to give to them the thought that many of the matters deserve. But I have had the advantage of advice, assistance and many helpful suggestions from numerous friends, to whom it remains to make the following acknowledgments: To conversations (1920) with Dr. J. M. Miller, of the Bureau of Standards, on the subject of dielectric losses in antennæ; to the Harvard lectures of Prof. G. W. Pierce on the radiation from flat-top antennæ, with the assistance of which I was able to demonstrate the advisability of operating the transmitting antenna at its fundamental wavelength in this case; to Prof. L. A. Hazeltine, of Stevens' Institute of Technology, for information on designing power audion oscillators; to Mr. L. M. Hull, Whiting Fellow in Harvard University, for the use of material from his unpublished doctorate thesis, dealing with the calculation of the power output of the separately-excited audion oscillator; to Mr. E. S. Purington, formerly Associate Physicist in the Bureau

of Standards, who kindly supplied me with numerous oscillograms and data from his study of radio telephone modulation; to Mr. W. D. Loughlin, engineer of the U. S. Navy, for assistance in securing the electrical characteristics of certain commercial types of audions; to Mr. L. R. Damon, of the Federal Institute of Radio Telegraphy, and to Mr. W. G. Ellis, engineer of the U. S. Navy, for many practical suggestions; to Mr. K. B. Warner, Secretary of the American Radio Relay League for information concerning the League and the use of material and illustrations from its official publication, *QST*; to Mr. W. S. Fogg for most of the illustrations; and to the publishers for their encouragement and constant consideration shown in matters connected with the printing.

In the first impression freedom from error is hardly to be hoped for and I shall be grateful for the report of any which the reader may discover; other minor errors of typography and circuitual infelicities he may magnanimously overlook or silently emend.

STUART BALLANTINE.

PHILADELPHIA, PA.,  
May 17, 1922.



## CHAPTER I

### PRINCIPLES OF RADIO TELEPHONY

**1. Radio Telephony and Radio Telegraphy.**—Radio telephony may be designated as the art of transmitting spoken words through space without the means of connecting wires. Just as its sister art, the now very familiar wire telephony, constituted a great improvement over the cruder, slower, and more laborious wire telegraphy and supplanted it to a large extent, so also is this newest of communicational means destined soon to share the rapidly increasing burden of radio telegraphy. From a technical point of view the underlying principles of radio telegraphy and radio telephony are the same, the chief difference in detail being that in telegraphy the radiated energy is inelegantly chopped up into lumps to form the dots and dashes of the telegraph code, whereas in telephony it must be moulded to correspond to the modulations of the sounds to be transmitted.

Thus radio telephony, while obeying the same fundamental principles as radio telegraphy, is yet a more complicated mechanism, as might be expected since the finest modulations of the voice are to be transmitted instead of the characterless dots and dashes of the telegraph. It was just this refinement of modulation which radio telephony demands, this necessity, so to speak, of working in a plastic clay rather than in mosaic, that prevented it for many years from assuming its proper place with radio telegraphy in

communication. Commenting upon the difficulty of the problem and the relative ease of the two methods of signalling, Goldsmith remarks (*Radio Telephony*, New York, 1918) with singular justice: "The difference in degree is not far from that between ruling a dot and dash line and making a dry-point etching of an autumn landscape."

The problem is further complicated by another element, the *size* of the job. Relatively enormous quantities of electrical energy are required for radio transmission as compared with wire communication because the radio waves are not guided as in the latter case by wires, but spread out over the earth's surface in all directions; consequently but a small fraction of the original radiation reaches the receiving station. This greatly increased energy of the transmitter must be controlled by the relatively feeble voice waves generated when we speak into the transmitter. It is very much like prodding an elephant with a toothpick. It was, therefore, not until DeForest invented that remarkable amplifying device known as the "audion," and the application of it to magnifying the feeble voice effects, that the art of radio telephony came into its own.

Most of the development of radio telephony has taken place since about 1914, and received great stimulus from the War, chiefly on account of its great military importance as a means of rapid communication between aircraft and their bases and between ships at sea. A great portion of this work was done in this country by DeForest, and in the research laboratories of the Navy and Army, and of the large electrical organizations such as the Western Electric Company and the General Electric Company. As in the case of the radio telegraph, no man invented it—in spite

of a popular view—and the credit for the beautiful mechanism as we know it today must be very widely distributed.

**2. What is Electricity?**—Perhaps the most natural and therefore, the first question most frequently asked by the layman is this: *What is electricity?* A harder one can hardly be imagined. So far as I am aware the question is unanswerable, since electricity is a something which enjoys a unique existence and cannot therefore be described in terms of things more familiar to the inquisitor. We might reply, enigmatically, that "*Electricity is electricity,*" or that it is a perfectly good *word* used in discussing something which we can neither see, hear, smell, taste or feel, and whose presence and actions are evident to us only through other physical effects, such as heat, light, mechanical forces, etc. But in spite of the enormous handicap of this indirect method of dealing, our knowledge of it is by no means scant, and indeed, there has been amassed in the past thirty years an astonishing amount of information concerning it and its ultimate relation to material things. From the study of this we now believe that matter, instead of being itself fundamental, as was formerly supposed, is entirely made up of electricity. This view is embodied in, and forms the substance of, what is called *the electron theory of matter*.

**3. Fundamental Ideas and Experimental Facts of Electricity.**—In this section it is proposed to review very briefly only so much of the material included by the above caption as is considered essential to a simple explanation of the principles of radio telephony.

(a) **The Electric Current.**—When electricity moves or flows from one place to another there is said to be an *electric current*. Of such currents we shall be interested in two

types: those which flow in conducting substances, called *conduction currents*; and those which flow through free space like a flock of birds, and are called *convection currents*. The first kind of current is familiar to all of us; the second class we meet with in the "audion." The conduction current alone will be considered here, and will be referred to as *the current* unless otherwise stated. Such a current flows through a metallic wire connected to the terminals of an electric battery, as shown in Fig. 1. In this simple case the

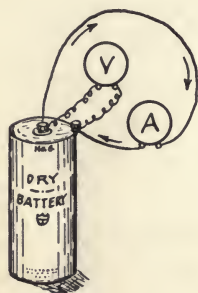

Fig. 1.—Electric current in simple circuit.

terminal voltage of the battery (measured by the voltmeter,  $V$ ) is the driving force, and the quantity of current which flows (measured by the ammeter,  $A$ ) will be determined by the conducting qualities of the wire circuit. Substances differ in their ability to conduct the electric current. (Some of them are, in fact, regarded as insulators, or non-conductors, because they permit its passage in such small quantities.) This conducting property of

an electrical circuit, or device, when steady currents are involved, is called its *conductance*, or reciprocally, its *resistance*, and an important relation involving it exists between the current which flows and the impressed *electromotive force* (*e.m.f.*).

(b) **Ohm's Law for Steady Currents.**—This relation is known as *Ohm's law* and may be stated as follows: The current which flows in a circuit in response to a steady impressed e.m.f.,  $E$ , is equal to this e.m.f. divided by the resistance of the circuit; or algebraically stated,  $I = E/R$  (where  $I$  is the current, and  $R$  the resistance). If in the above law the

e.m.f. is given in *volts* and the resistance in *ohms*, then the current will be expressed in *amperes*.

(c) **Resistances Connected in Series and in Parallel.**—In the case of a more complicated form of circuit in which there are different kinds of conductors connected in series, or where there are two or more paths for the current, the value of resistance to be inserted in this formula is determined by the following rules:

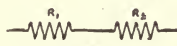
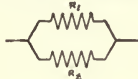
	$R = R_1 + R_2;$	<i>(resistances in series),</i>
	$R = \frac{R_1 R_2}{R_1 + R_2};$	<i>(resistances in parallel).</i>

With the aid of these relations the current flowing in any circuit or branch of any circuit which obeys Ohm's law, can be computed.

(d) **Effects of the Current.**—We are able to detect the passage of current through the wire in Fig. 1 by two principal effects:

1. Heating effect.
2. Magnetic effect.

The *heating effect* is caused by the friction of the electricity in flowing through the wire, by means of which some of the electrical energy is converted into heat and therefore from the electrical point of view, lost. This is called the *Joule* effect, or the *Joule* loss. The rate at which heat is generated in this way is equal to the resistance multiplied by the square of the current, or algebraically:  $Heat = I^2R$ . This effect is a familiar one on our every-day life, being utilized in the electric incandescant lamp, arc lamp, electric heaters, and so forth.

The *magnetic effect* may be described as follows: Fig. 2 shows a solenoid carrying a steady current due to the battery,  $E$ . If a magnetic compass,  $C$ , is placed at various positions in the neighborhood of the solenoid its needle will be found to be affected and to take up approximately the positions shown by the dotted lines of this figure. The force which deflects the needle is a *magnetic force*, and by this exploration with the compass we have mapped out the *magnetic field* of the solenoid. The magnetic force (designated by the letter,  $H$ ) has the direction of the dotted lines

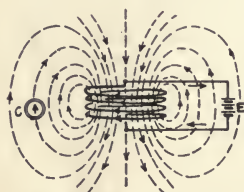

Fig. 2.—Magnetic field of solenoid carrying steady current.

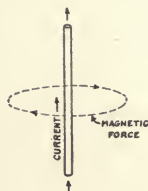

Fig. 3.—Showing relation between directions of current and magnetic force.



Fig. 4.—Illustrating right-hand rule.

in the diagram. The *lines of magnetic force* are always *closed* when there are no magnetic substances, such as iron, in the field. Their direction is simply related to that of the current by *Ampere's Rule*, which is illustrated by Fig. 3. Here the current flows in the straight conductor and gives rise to the circular lines of magnetic force, shown dotted. The arrows indicate the relations; or they may be kept in mind by the device of supposing that if on the right hand the thumb points in the direction of the current, then the fingers will give the direction of the magnetic force, and *vice versa* (see Fig. 4). This remarkable relation be-

tween electricity and magnetism is of great importance in radio communication, as in many other electrical applications.

(e) **Electromagnetic Induction. Faraday's Law of Induction.**—

We come now to the discussion of an effect which is the converse of the above. Instead of inquiring as in this case into the creation of a magnetic field, let us assume that one is already created, either by means of an electric current or by a steel magnet. In this field place a solenoid whose circuit is closed through the current indicating instrument, *A*, Fig. 5. Now so long as the field is undisturbed, or constant, the ammeter will register no current; but as soon as the number of lines of force embraced by the solenoid is changed, either by moving the source of the field or by moving the solenoid itself through the field, a current will be indicated. Indeed, this we would naturally expect, for if a current is capable of producing a magnetic field (which represents energy), so conversely should the change or disappearance of this field be capable of delivering back to the circuit, or any other circuit, some of this energy. If the circuit is closed, a current flows; if the circuit is not closed there is still generated an e.m.f. capable of driving a current when a path is provided. This phenomenon is known as *electromagnetic induction*, and also has important applications in the electrical world, in dynamos, etc., and in radio communication.

It was first extensively studied experimentally by Faraday, who disclosed the following fundamental law regarding it: *The e.m.f. induced in a closed electrical circuit by a varying magnetic field is equal to the rate at which the total flux of magnetic induction linked with it positively is decreasing*

with respect to time. This is known as the *first law of induction*.

(f) **Magnetic Coupling Between Two Circuits. Mutual Induction.**—Instead of producing the variation of the magnetic field by moving the circuits as in the last paragraph, let this be accomplished by varying the current in the first (1) circuit (Fig. 5). An e.m.f. will be induced in the second (2) circuit as before, and since the circuits are fixed in position its value will depend upon the time rate of decrease of the current in circuit (1), and the geometry of the circuits; thus  $e_2 = M \times \text{rate of decrease of current in (1)}$ .  $M$  is a constant,

called the *coefficient of mutual induction* and depends upon the linkage of the flux from (1) through (2), or upon the “coupling” of the circuits. Two circuits related in this manner are said to be *magnetically coupled*.

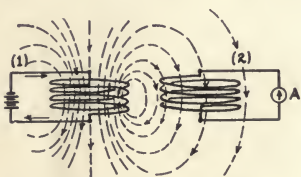

Fig. 5.—Illustrating electromagnetic induction.

(g) **Self-induction.**—It has been explained that the variation of the magnetic flux through a circuit induces therein an e.m.f. Such a variation of magnetic flux will be produced when, after connecting the coil in Fig. 2 to the battery, the current begins to rise and tends to establish the steady value given by Ohm’s law. The circuit reacts upon itself, inducing an e.m.f., called the *back e.m.f.*, opposed to that of the battery and acting to restrain the swift rise of the current which would otherwise take place. This phenomenon is known as *self-induction* and is very similar to the inertia of mechanics which is manifested when a massive body is acted upon by a suddenly applied force (Fig. 6).



In this case the motion of the body lags behind the application of the force just as in the electrical circuit the current lags behind the application or change of the electric force.

This property of an electric circuit, by virtue of which it opposes changes in the current, is termed its *coefficient of self-induction*, or simply its *inductance*, and is denoted by the letter  $L$ . It is defined in terms of the back e.m.f. induced as follows:  $e = L \times \text{rate of decrease of current}$ , and depends only upon the geometry of the circuit, that is in the case of the solenoid, upon its dimensions, number of

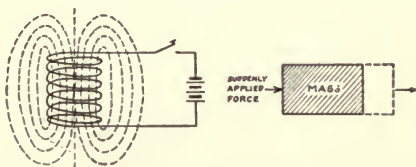

Fig. 6.—Mechanical analogy of self-induction in an electric circuit.

turns of wire, etc. The practical unit of inductance is the *henry*, defined as the inductance required to produce a back e.m.f. of one volt when the current is changing at the rate of one ampere per second. For radio purposes where small coils are used, subdivisions of this unit are convenient and customarily employed as follows:

- 1 milli-henry (m.h.) = .001 h.
- 1 micro-henry ( $\mu$ .h.) = .000001 h.
- 1 centimeter (cm.) = .000000001 h.

Inductance has the dimensions of a length and might also be expressed in feet or miles; but this practice has fortunately not yet been established.

The energy stored in a magnetic field associated with a circuit carrying a steady current  $I$ , is equal to  $\frac{1}{2}LI^2$ .

Inductance coils (inductors) connected in series and parallel in such a way that there is no coupling between them, are computed by rules given in Art. 2 (c) for resistances.

(h) **Forms of Inductors for Radio Telephone Circuits.**—Inductance is one of the most important properties of a radio circuit, as we shall presently see, and many forms of “inductances” (more properly *inductors*) or “load-coils” are employed. These may be divided into two classes: those of fixed value, and those whose inductance can be varied.

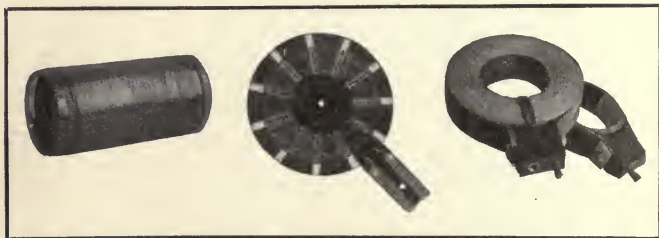

Fig. 7.—Some types of fixed inductors for radio receiving circuits.

Generally these inductors take the form of coils wound in various ways with a conductor having a low resistance for the radio frequency (r.f.) currents. A number of such coils of fixed values designed for use in radio frequency circuits are shown in Fig. 7. The inductance for a coil of given dimensions may be increased by inserting an iron core; this is often done for low frequencies or direct current (d.c.), but is not advantageous for the very high frequency currents used at amateur wavelengths on account of large heat losses in the iron core. Typical forms of variable inductors are shown in Fig. 8. This depicts a very convenient and

popular type suitable for use in receiving circuits where low currents are encountered. Technically this inductor is called a "variometer" and the principle of its adjustment is as follows:

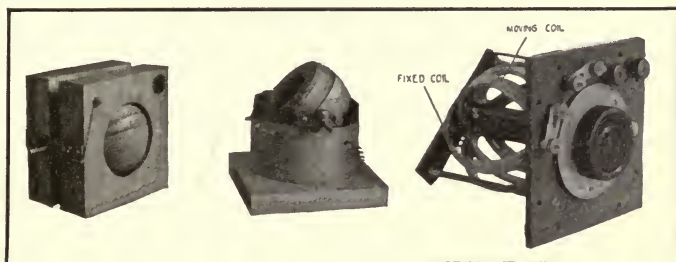

Fig. 8.—Types of variable inductors for radio receiving circuits.

Figure 9 shows at (a) two coils  $L_1$  and  $L_2$  wound in the same direction so that their fields are additive and the mutual inductance between them is positive. The effective induct-

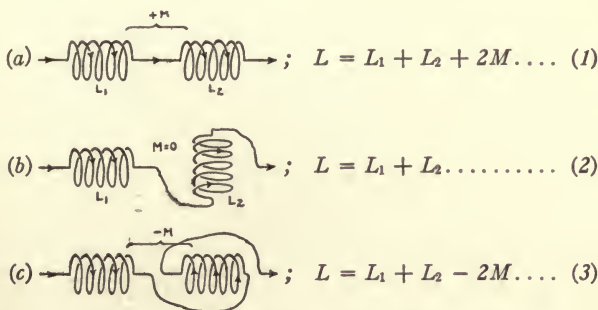

Fig. 9.—Illustrating principle of the variometer.

ance of the arrangement is larger than the sum of their separate inductances by twice the mutual inductance. [Equation (1).] If they are placed so that there is no coupling between them, at right angles for instance, as

shown at (b), the effective inductance will be simply  $L_1 + L_2$ . But if one of the coils is reversed, so that their mutual inductance is negative, the inductance will be less than the sum  $L_1 + L_2$  by twice the mutual inductance. [Equation (3).] Thus by simply varying the coupling between two coils connected in series a variation of the total inductance may be produced. This is the principle of the variometer and in the types illustrated above the coupling is varied from full positive through zero to full negative by rotating one of the coils through 180 degrees. This gives a smooth variation of the inductance difficult to obtain in any other

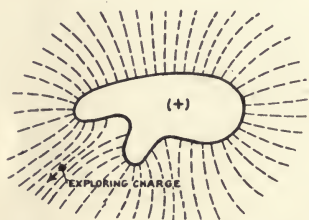

Fig. 10.—Electric field of a charged conductor.

way and for this reason the instrument is a very valuable one in radio circuits requiring close adjustment. They are rather well developed and many different types are available on the market at very reasonable prices.

(i) **The Electric Field.**—We have considered the magnetic field, particularly as produced by an electric current; let us now discuss the *electric field*. Figure 10 shows a conductor upon which an electric charge has been placed. In the magnetic case the field was explored by means of a magnetic compass needle; here we shall employ a small particle carrying a unit charge of positive (+) electricity. As this exploring charge is placed in the different positions it will be urged in various directions with various intensities. The mechanical force thus observed is a manifestation of the *electric force* and serves as a means of measuring and defin-

ing it. If the direction in which the particle is urged is plotted for its various positions, the *lines of electric force* shown in Fig. 10 will be obtained, analogous to the lines of magnetic force of Fig. 2. But unlike the latter these lines *are not closed* (in the steady field), but terminate upon electric charges.

(j) **Electrostatic Capacity. Condensers.**—The ability of a conductor to become charged as above is termed its *electrostatic capacity*, or simply its *capacity*. This ability depends among other things upon the size of the conductor and upon the proximity of other conductors in the field. It may be in-

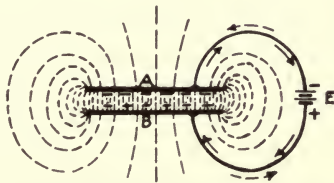

Fig. 11.—Parallel plate electric condenser.

creased for a conductor of given dimensions by means of an arrangement shown in Fig. 11. The parallel plates *A* and *B* are preferably of large area and are separated by a small distance. The field and the electrostatic energy it represents is thus largely concentrated in the space between the plates, and on account of this the device is called a *condenser*. Its capacity is directly proportional to the area of the plates and inversely proportional to their separation. When the plates are connected to the battery, *E*, a current flows through the circuit in the direction of the full line arrows, conveying charges which accumulate upon the opposing surfaces of the plates. The condenser is then said

to be *charged*. The electrostatic energy stored in the field is  $\frac{1}{2}CE^2$ , where  $E$  is the voltage between the plates. If the battery is now removed and replaced, let us say, by a resistance, the condenser will *discharge*, that is, a current will flow (dotted arrows) until the charges on  $A$  and  $B$  are equalized.



Fig. 12.—Mechanical analogy of the charged condenser.

Thus in the charged condenser there is a state of tension which has its mechanical analogue in the state of a stretched spring (Fig. 12), and the electrical energy corresponds to the potential energy of the stretched spring. Each will do work if the opportunity is provided.

Condensers connected in series and in parallel are computed by the following rules:

$$\begin{array}{l} \text{---} \parallel \overset{C_1}{\text{---}} \text{---} \parallel \overset{C_2}{\text{---}} \text{---}; \quad C = \frac{C_1 C_2}{C_1 + C_2}, \quad (\text{capacities in series}), \\ \text{---} \text{---} \parallel \overset{C_1}{\text{---}} \text{---} \parallel \overset{C_2}{\text{---}} \text{---}; \quad C = C_1 + C_2, \quad (\text{capacities in parallel}). \end{array}$$

It will be noticed that the effect of these connections is opposite to that in the case of inductance and resistance; connecting condensers in parallel, for example, increases the total capacity, whereas in the case of resistance and inductance the composite value is diminished.

The practical unit of capacity is the *farad*, defined as the

capacity required to pass a current of one ampere when the voltage across it is changing at the rate of one volt per second. (Cf. definition of unit of inductance, Art. 2 (g).) This unit is, however, much too large for practical use (the capacity of a sphere the size of the earth is only .005 farad), and subdivisions are convenient and generally employed in practice as follows:

1 micro-farad	(mfd.)	= .000001 f.
1 micro-micro-farad	(mmfd.)	= .000000000001 f.
1 centimeter	(cm.)	= .00000000000111 f.

(k) **Specific Inductive Capacity. Dielectrics.**—It is found experimentally that the capacity of the parallel plate condenser is increased by inserting a piece of glass, mica, paraffined paper, etc., between the plates. This discovery is often utilized in the construction of condensers and permits a great saving in space and materials in building a condenser of given capacity. The voltage at which the condenser breaks down, that is, at which disruptive discharge takes place between the plates, is also often considerably increased by the use of these materials. The ratio of the capacity with and without the substance between the plates is called the *specific inductive capacity*, or simply *dielectric constant* of the material; and is a positive number greater than unity for all materials at radio and lower frequencies. Non-conducting substances which possess this property are called *dielectrics*. The dielectric constant of air at ordinary pressures and temperatures is not appreciably greater than unity.

(l) **Forms of Condensers for Radio Circuits.**—With inductance, the capacity of or in a radio circuit is a property of funda-

mental importance. Condensers for radio work take a variety of forms, with both fixed and variable capacity values. For transmitting purposes where high voltages and large amounts of power are involved, the condenser must be designed to withstand the voltages and to dissipate the heat lost in the dielectric. For such condensers glass and mica dielectrics are generally used; a well-chosen grade of mica makes a particularly good condenser because its dielectric constant is moderately high, and its great dielectric strength



Fig. 13.—Types of condensers for radio circuits: (a) Mica condenser for transmitting circuits; (b) and (c) variable condensers for receiving circuits.

permits thin sheets to be used thus yielding a condenser of large capacity and small dimensions. For receiving purposes *variable condensers* are extensively employed, of which there are quite a variety of types on the market. Two of these are illustrated in Fig. 13. The dielectric is generally air because there is no necessity for insulating high voltages, as in transmitting circuits, and an air dielectric has very little loss. The capacity is varied by rotating the plates of one set between those of the other set.



**4. Alternating Currents.**—Leaving now the province of direct or steady currents and voltages, let us take up the discussion of currents which vary; this is, of course, the class of greatest interest in radio communication as in most other applications of electricity. The simplest and most frequently appearing type of variable current is that known as the *sinusoidal* or *simple harmonic (s.h.)* type. This kind of variation is illustrated in Fig. 14. The horizontal distances represent the time and the vertical distances represent the value of the current or voltage at that instant of time. The term “sinusoidal” follows from the fact that the current value at any instant is a trigonometric *sine* function of the time. As shown, the current undergoes a complete

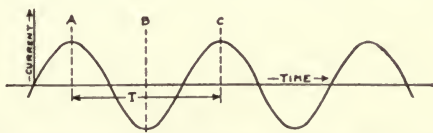

Fig. 14.—Illustrating sinusoidal, or simple, harmonic type of alternating current.

reversal from *A* to *B*, and a complete cycle from *A* to *C*. The number (*n*) of such cycles passed through per second is called the *frequency*; and the time,  $T = 1/n$ , required for the completion of one cycle is called the *periodic time* or the *period*. Alternating currents of this type are used extensively in many every-day electrical applications; for power and lighting purposes, where the frequency is relatively low (60 cycles per second); for wire telephony, in which the frequencies may vary from 100 to 5000 cycles; and for radio communication where they are much higher, from 30,000 to 2,000,000 cycles. We shall consider first the effect of impressing an a.c. voltage of this type upon simple circuits containing inductance, capacity and resistance.

(a) **Circuit Containing Resistance.**—Figure 15 (a) shows an a.c. generator connected to a circuit containing resistance. In this case the current flowing at any instant will be given by Ohm's law, that is, it will be proportional to the volt-

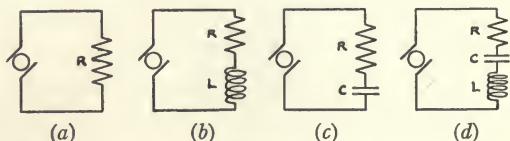

Fig. 15.—Simple a.c. circuits containing inductance, capacity and resistance.

age, inversely proportional to the fixed resistance. The current variation may be shown graphically, as at (a) Fig. 16, where the full line represents the impressed voltage

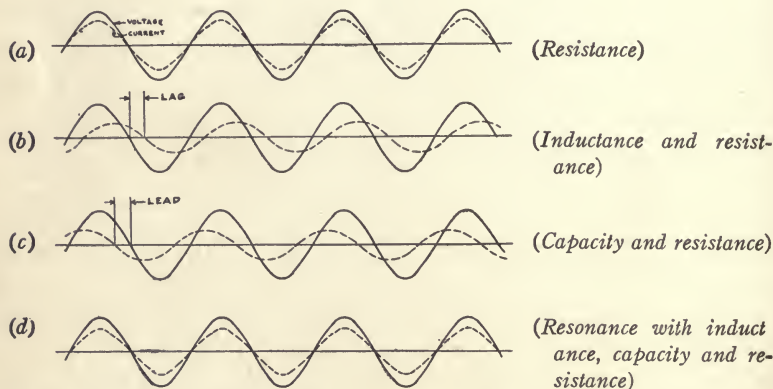

Fig. 16.—Currents and voltages in a.c. circuits of Fig. 15 containing inductance, capacity and resistance.

and the dotted line the resulting current. The current keeps time with the voltage, reaching its zero and maximum values simultaneously with it, and on that account is said to be "in-phase."

(b) **Circuit Containing Inductance and Resistance.**—We noticed in a previous paragraph that self-induction had a tendency to suppress variation of the current. This effect is important here, and an a.c. circuit containing inductance is found to offer a greater resistance to the passage of current than can be accounted for by Ohm's law and the resistance of the circuit alone. This impedance depends, moreover, upon the inductance and frequency. The current is no longer given by Ohm's law, but must be calculated from the new law:  $I = \sqrt{R^2 + \omega^2 L^2}$ . The factor  $\sqrt{R^2 + \omega^2 L^2}$  is called the *impedance* of the circuit;  $\omega = 2\pi \times \text{frequency}$  is called the *angular velocity* corresponding to the frequency  $n$ . Note that the choking effect of the inductance increases with the frequency. In addition to the limiting effect the inductance also causes the current and voltage to be out of step and the current "lags" behind the e.m.f. as shown at (b), Fig. 16. The current is still sinusoidal in form.

(c) **Circuit Containing Capacity and Resistance.**—A condenser prevents the flow of a steady current through a circuit, but permits the passage of a.c. in proportion to its capacity and the frequency of the a.c. In series with a resistance, as at (c), Fig. 15, the impedance offered to the a.c. voltage is  $\sqrt{R^2 + 1/\omega^2 C^2}$ . In this case, however, the current instead of lagging behind the e.m.f. as in the case of inductance, actually precedes it, or "leads," as shown at (c), Fig. 16. The amount of this lead depends upon the product of resistance and capacity.

(d) **Circuit Containing Inductance, Capacity and Resistance. Resonance. Tuning.**—We come now to the most interesting and important case, that of a circuit with all three constants  $L$ ,  $C$  and  $R$ . Comparing cases (b) and (c) it will be

observed that inductance and capacity have opposite effects, the first causing the current to *lag*, and the latter to *lead*. Thus when combined the impedance of the circuit is  $\sqrt{R^2 + (\omega L - 1/\omega C)^2}$ . It is evident that if  $L$  and  $C$  are properly chosen an exact neutralization of their effects may be had. To bring this about the simple relation,  $\omega L = 1/\omega C$ , must be satisfied, and when this adjustment is made the current is a maximum and is given simply by  $I = E/R$ , as in the case of a simple resistance; the circuit then acts in fact as if resistance alone were present and the current is in phase with the voltage as shown at (*d*), Fig. 16. (Compare with (*a*), Fig. 16.) This condition is known as *resonance* and the adjustment of the inductance and capacity to bring it about is commonly called *tuning*. The operation of tuning is very important in radio work, its purpose being generally in this case to obtain a maximum flow of current in a circuit, as for example, in the case of a receiving antenna. Obviously instead of tuning the circuit we can also produce resonance for a given  $L$  and  $C$  by adjusting the frequency.

**5. Electric Waves.**—When the smooth surface of a pond is disturbed by throwing a stone into it, ripples are formed which spread out along the surface in a series of miniature circular water waves. This is one of many familiar examples of wave motion. The waves so formed will travel with a definite velocity of a few meters per second, and carry with them energy capable of setting into motion a small distant floating object upon which they may be incident. Replace the stone by the radio transmitting station, the floating object by the radio receiver, the water by the “ether,” and conceive of *ether waves* or *electric waves* instead of the waves in the water, and an idea of the funda-

mental scheme of radio communication will be secured. In the radio case, however, the waves travel with the relatively enormous velocity of approximately *186,000 miles per second*.

The exact structure and nature of the electric waves is somewhat harder to describe and to understand. In the case of water waves we have to deal with the propagation of a vertical displacement of the water; in that of electric waves with the propagation of electric and magnetic forces, a physical picture of which is not easily drawn. The medium through which these forces are propagated is called the *ether* and is not ponderable, and cannot be seen or sensed in any way, like the water medium. The ether is a very subtle thing and appears to defy physical description; there are, in fact, a number of reputable scientists who refuse to have anything to do with the idea, preferring to regard it as being sufficiently described by the mathematical equations. So we shall not attempt the impossible here, avoiding this pitfall of so many works on the subject of electric waves; but will be content to remark that the electric waves travel through something and that something is called the ether. The electric and magnetic forces are states of it, and it occupies all space, permeating even the interior of solid substances. Hence electric waves have little difficulty in passing through insulating substances like wood, but do not, of course, pass thus unrestrained through conductors. It is understood that we are speaking of long waves, as in radio communication.

Electric waves play a very important part in our everyday life; heat, light and the X-ray are all propagated by their means. The velocity in all cases through free space

is the same, viz., 186,000 miles (300,000,000 meters) per second, and because it was first measured in connection with light rays, is popularly referred to as the *light-velocity*. The various radiations differ, however, in their wavelengths. In the water waves the *wavelength* is easily measured as the distance from the crest of one wave to that of its successor; in the electric case it is the distance from one maximum of electric or magnetic force to the next maximum. There is a simple relation between the wavelength and the frequency of vibration of the source, or with which the floating object (in the water case) or a receiving antenna (in the radio case) vibrates when the wave acts upon it. This may be explained with the aid of Fig. 17 as follows:

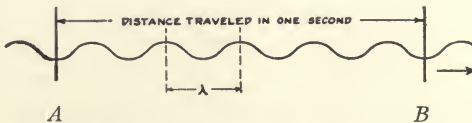

Fig. 17.—Illustrating relation between wavelength and frequency in a sinusoidal wave.

Here  $AB$  represents the constant distance the wave travels in one second, regardless of its wavelength, frequency, etc. Now if the waves are generated at the rate of  $n$  per second it is evident that precisely  $n$  of them will be between  $A$  and  $B$  at any given time. The length of one wave (usually denoted by the Greek letter,  $\lambda$ ) will therefore be  $AB \div n$ , or *velocity*/ $n$ . It should be noticed that the wave length is a characteristic of the wave and has nothing whatever to do with the distance it travels.

The chart of Fig. 18 gives a graphical comparison of the waves of X-ray, light, heat and radio. The enormous dif-

ferences in wavelength, *i. e.*, from .000,000,000,01 meter to 10,000 meters, cannot be represented to scale, but are marked in the diagram. These differences in wavelength account for the differences in their phenomena; fundamentally they are all electric waves.

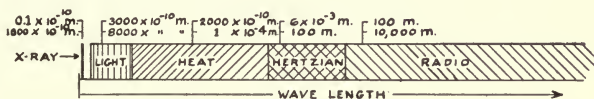

Fig. 18.—Chart comparing wavelengths of X-radiation, light, heat, Hertzian and radio waves.

**6. Production, Transmission and Reception of Radio Waves.**—The special electric waves of radio communication, called *radio waves*, will now be described, and their radiation from the transmitting antenna, their propagation over the earth's surface, and finally their effect upon the distant receiving antenna will be briefly explained.

(a) **Production.**—As before let us employ a mechanical analogy; the water waves of the last section will do. Imagine then, a cork floating upon the water to which, by hand or otherwise, an up-and-down motion is imparted.

This will produce a series of waves, and if the motion is a regular one, a series of waves of uniform wavelength. In the radio case the transmitting antenna replaces the cork

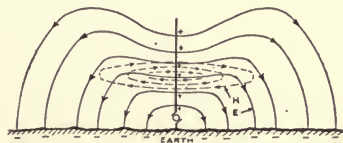

Fig. 19.—Illustrating radiation of radio wave from simple vertical antenna.

and the current therein, flowing up and down, corresponds to the latter's motion. Figure 19 shows a simple type of antenna connected to a generator of a.c. of radio frequency.

The antenna has both inductance and capacity, hence according to the paragraph on "resonance," either the frequency of the a.c. voltage is to be adjusted for resonance or the  $LC$  constants adjusted by means of additional coils and condensers. When the adjustment has been made a maximum a.c. current will flow in the antenna. This current will produce a magnetic field (shown by the dotted lines) and an electric field (full lines) which travel out from the antenna with the speed of light and constitute the emitted radio

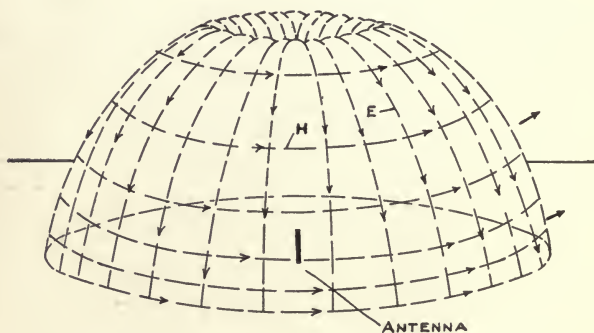

Fig. 20.—Airplane view of electric wave radiated by simple vertical transmitting antenna, showing direction of electric and magnetic forces.

wave. Figure 20 shows the wave just after emission as it might appear to an airplane observer able to see the electric ( $E$ ) and magnetic ( $H$ ) forces. Figure 21 is a cross-section through Fig. 20 and shows in detail the electric lines for the first few waves. These, it will be observed, are vertical near the earth, while the magnetic lines (shown in section by the dots and crosses; dots pointing toward the reader, crosses away from him) are horizontal and circular with the



axis of the antenna as their center. The electric and magnetic fields just described are inseparable in such a wave and proceed, so to speak, hand in hand.

The wavelength,  $\lambda$ , is indicated as the distance between successive crests and is related to the frequency of the antenna current by  $\lambda = v/n$ , as already explained. Theoretically, if the vertical antenna contains no extra inductance or capacity in the form of a load in series with it, and

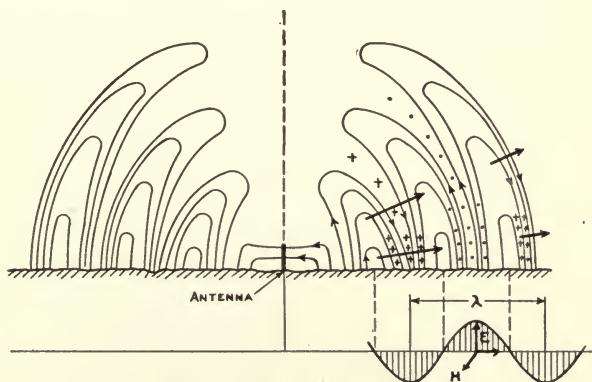

Fig. 21.—Cross-section through Fig. 20 showing lines of electric force ( $E$ ) in first few waves. Magnetic lines ( $H$ ) shown in section by arrows ( $\cdot$ ) toward reader, ( $+$ ) away from reader.

the generator frequency is adjusted for resonance, the wavelength of the emitted waves will be very nearly four times the length of the wire; for example, a wire 50 meters high would radiate waves of approximately 200 meters wavelength. This is termed the *fundamental wavelength* of the antenna and is the wavelength at which most efficient radiation takes place. If it is desired to radiate waves longer than the fundamental, an inductance is inserted in

series with the antenna as shown at (a), Fig. 22. Waves shorter than the fundamental are produced by connecting a condenser in series as shown at (b). This process is termed *loading the antenna*.

(b) **Transmission.**—The hemispherical wave whose genesis has just been described expands at the velocity of light, retaining its hemispherical shape, and being guided at its

base by the conducting surface of the earth. Actually the earth is not a perfect conductor, consequently the wave, instead of gliding along its surface as it would in the case of perfect conductivity, penetrates it to some extent and induces currents which produce heat loss. Some of the original energy of the wave is lost in this way. Moreover, since the energy is distributed over the entire surface of the wave, the amount contained in a unit surface layer continually diminishes as the wave expands; the electric and magnetic forces diminish, in fact, very

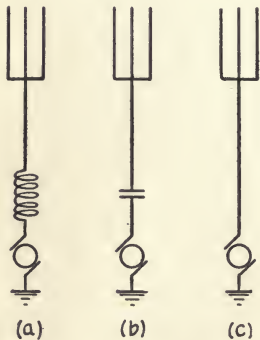

Fig. 22.—Loaded antennæ; arranged to produce: (a) Waves longer than fundamental, (b) waves shorter than fundamental, (c) waves of fundamental wavelength.

nearly *inversely* as the distance from the source, and the energy diminishes *inversely* as the square of this distance as in the case of other radiations, heat, light, etc. In addition, there are other sources of energy loss, such as scattering by upper atmospheric layers, absorption by terranean objects, trees, etc., which we have no space to consider in detail.

(c) **Reception.**—Consider now the effect of this wave upon an antenna used for receiving purposes, Fig. 23. In ac-

cordance with the principles of electromagnetic induction of Art. 2 (*e*) there will be induced therein an e.m.f. whose frequency will be that of the wave and consequently that of the transmitting current. From an electrical point of view the antenna circuit is equivalent to that shown at (*b*) Fig. 23, where  $L_a$ ,  $C_a$  and  $R_a$  represent respectively the effective antenna inductance, capacity and resistance; and  $L_o$  and  $C_o$  the inserted tuning inductance and capacity. The e.m.f. due to the passing wave is represented by  $e$ .

The current in the antenna is used to activate the detecting instruments (to be subsequently explained) and in order that it shall be as large as possible,  $L_o$  and  $C_o$  are adjusted so that the circuit is in resonance with the induced e.m.f. When the circuit

is tuned in this manner, the current is a maximum, being limited only by the resistance.

**7. Résumé; the Mechanism of Radio Transmission.**—

The fundamental processes just described may be summed up as follows: A generator, or source of radio frequency energy, is connected to the transmitting antenna and produces therein an alternating current. The oscillation of the current produces in turn varying electric and magnetic states of the ether which travel outward in hemispherical electric waves at the velocity of light. Impinging upon a distant receiving antenna properly tuned these waves produce in it an alternating current of the same

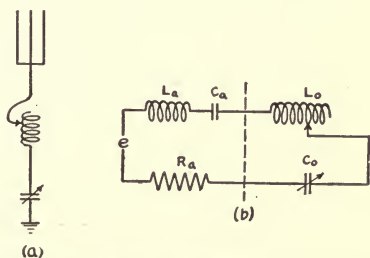

Fig. 23.—Receiving antenna (a), and its equivalent electric circuit (b).

type and frequency as that in the transmitting antenna. The presence of these currents is made evident to us by a detecting means to be presently described. Thus we have a system whereby radio frequency currents at one place are capable of producing identical currents (of much diminished amplitude) at a distant place. The radio telephonic utilization of this scheme for the transmission of sounds will be considered.

**8. Principles of Telephony Over Wires.**—It will be helpful, before attempting to explain the principles of radio telephony, to briefly discuss the theory of ordinary tele-

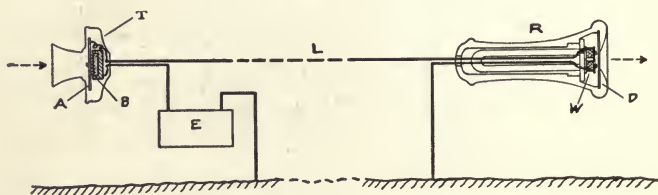

Fig. 24.—Illustrating simple wire telephone circuit.

phony over wires, since between the two interesting analogies may be drawn and there is besides some didactic advantage in progressing from the familiar to the unfamiliar and from the simple to the complex.

The scheme of a simple wire telephone is illustrated in Fig. 24. Here *T* represents the *transmitter*, into which the words are spoken at the sending end; *E* is the source of power, or electrical energy, and usually consists of a battery of constant voltage; *L* is the metallic line; and *R* is the *telephone receiver*. The operation of this circuit as a telephone is somewhat as follows:

When words are spoken into the transmitter the dia-

phragm *A* is set into vibration in accordance with the speech sounds. The space between the electrodes *A* and *B* is loosely packed with carbon granules which offer to the passage of current a resistance which depend upon the degree of compression to which they are subjected. Obviously by this means the current is varied in accordance with the diaphragm's vibrations and the speech sounds, or technically we say that the current is *modulated*. The modulated current flowing through the windings *W* of the telephone receiver produces a similar vibration of its iron diaphragm *D*, reproducing in this way the original speech.

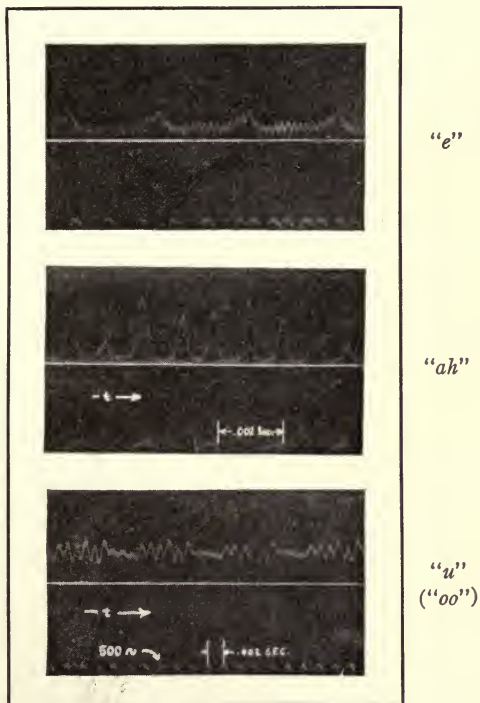

Fig. 25.—Photograph of current variations in wire telephony, produced by three vowel sounds spoken into the transmitter of the circuit, Fig. 24.

In Fig. 25 are shown some interesting photographs of the current variations which are produced in a circuit of this type by various vowel sounds spoken into the transmitter. These irregular vibrations may be regarded as being com-

pounded of a number of pure sinusoidal currents of various amplitudes and frequencies. From this point of view the principle frequency of speech is often said to be 800 cycles per second; although the entire range from 100 cycles to 5000 cycles is necessary for the transmission of speech of high quality. Thus in Fig. 25 the modulation in the vowel sound "e" takes place with a frequency of 2250 cycles, of which a chief modification occurs at a lower frequency of about 170 cycles. In the letter "s" the frequency of the sound is still higher.

These alternating currents are the carriers of the speech. In flowing through the line they are accompanied by elec-

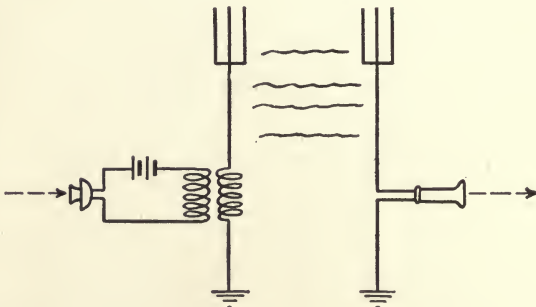

Fig. 26.—Simplest scheme for wireless telephony, using voice currents directly.

tric and magnetic forces in the ether, these states traveling along with them to form an electric wave gliding along the wire. Such an electric wave is said to be *guided* and in the case of the usual two-wire transmission, the waves are called *double-cored waves*. Thus a message conveyed by this kind of wave goes right to its destination and does not, as in the case of radio waves, spread out in all directions.

It is natural to suggest at this point that the wire be dispensed with and a radio telephone system produced by connecting the transmitter and receiver to antennæ as shown in Fig. 26. This is quite possible, but not feasible for the following reasons: As already mentioned the telephone current frequencies range from 100 to 5000 cycles. The wavelength emitted at a frequency of 1000 cycles would be 300,000 meters. To secure most efficient radiation at this wavelength it would be necessary to build an antenna  $300,000 \div 4 = 75,000$  meters, or about 46.6 miles long! This would indeed be an ambitious project. Satisfactory work might be done with antennæ from 10 to 20 miles in length, but the radiation from the average antenna as we know it would be negligible at these frequencies. Thus it is apparent why this most obvious system of radio telephony is impracticable and recourse must be had to the more complicated methods with which this book is concerned and which will now be described.

**9. Principles of Radio Telephony.**—We have just pointed out how difficult radio telephony would be if attempted with the low frequency currents directly. What we require then is a system wherein higher or radio frequency currents are utilized in the wireless transmission; then the energy can be effectively radiated and received by antennæ of practical size, and the transmission greatly improved. This radio frequency energy must, of course, be controlled and modulated in accordance with the speech sounds to be transmitted; and at the receiving station must be demodulated or translated back into the low frequency currents with which the telephone receivers are to be activated.

This is the essential principle of the radio telephone of

the present day. The schematic diagram of Fig. 27 will perhaps make it clearer. The RADIO FREQUENCY POWER SOURCE produces suitable radio frequency current in the transmitting antenna. The amplitude of this current is

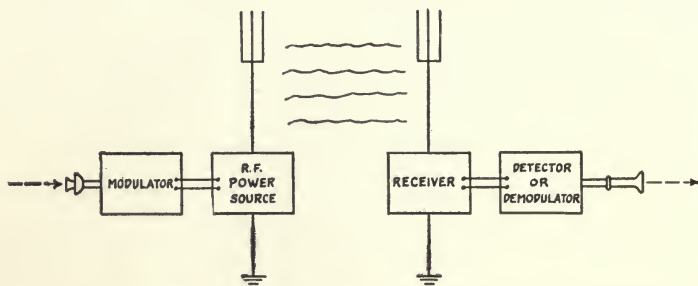

Fig. 27.—Illustrating the scheme of radio telephony using radio frequency carrier-waves.

caused to vary by means of the microphone assisted by the MODULATOR, to correspond to the speech sounds. The actual current in the antenna or the forces in the radiated

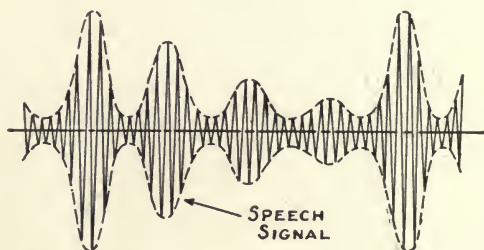

Fig. 28.—Type of signal used in radio telephony, showing high frequency "carrier-wave" modulated by speech current.

wave then appear about as shown in Fig. 28; and consist of a radio frequency wave, called for obvious reasons the *carrier-wave*, whose intensity undergoes variation at the much lower frequency of speech, viz., 100 to 5000 cycles.



This wave produces in the tuned receiving antenna a current of approximately the same form, which is decomposed by the DETECTOR into the original speech currents of low frequency, or a more or less faithful copy of them.

Comparing this with wire telephony we have:

*Radio Telephony*

Production of r.f. power;  
 Modulation;  
 Radiation, transmission and  
 reception;  
 Demodulation;  
 Reception by telephone re-  
 ceivers.

*Wire Telephony*

Production of d.c. power;  
 Modulation;  
 Transmission by wire;  
 Reception by telephone re-  
 ceivers.

Radio telephony thus appears to be a more complicated mechanism, at least in the broad outlines of the processes.

## CHAPTER II

### THE AUDION

**10. The Audion in the Radio Telephone System.**—The device to which this chapter is devoted occupies the keystone position in the radio telephone system. Its importance and versatility may be appreciated from the fact that in the radio telephone scheme, Fig. 27, it plays the parts of: (1) modulating device, or amplifier for the voice currents; (2) generator of radio frequency power for transmitting; (3) amplifier for the received radio frequency signals; (4) demodulator, or detector; and (5) is often employed for amplifying the signals after detection, either to secure greater intensity in the telephone receivers or for the operation of a “loud-speaker.” In these various applications it functions in two different ways: (1) as an amplifier, and (2) as a detector. Both of these functions will be explained in subsequent paragraphs.

**11. Description of the Audion.**—The name “audion” was originally given to the device by its inventor Dr. Lee De-Forest. It has since become fashionable to employ other designations such as, *three electrode vacuum tube*, or simply *vacuum tube (V.T.)*; *electron tube*, *thermionic amplifier*, *triode*, and while very high-sounding and-smacking of great erudition on the part of their users these terms are no more descriptive of the actual apparatus than the term “audion”; hence recognizing the prior right of the inventor in the

naming of his child we shall employ the term *audion* in this book.

The audion consists of three electrodes inclosed by a glass container which has been very carefully exhausted to a high vacuum. The first of these electrodes is an ordinary *filament* similar to those used in electric light bulbs and arranged to be heated in the same way, viz., by means of an electric current. The second electrode, called the *plate*, is simply a piece of metal (usually nickel) in the shape of an elliptic, rectangular or circular cylinder which surrounds the filament. The third electrode is called the *grid* and is interposed between the filament and plate. Its construction is such that small particles of electricity coming from the filament may pass through its meshes on their way to the plate. This is sometimes called the *control electrode*.

The construction of a typical device with plane electrodes is shown in Fig. 29, in which parts of the grid and plate have been cut away to show the relation between the three electrodes. Electrical connections are made in the usual way by bringing out leads through the glass mash to the base upon which four terminal pins are mounted; two for the filament and one each for the grid and plate. The bases of most commercial audions have been standardized, and are of the



Fig. 29.—View of audion with plane electrodes in which the glass container and part of the electrodes have been removed to show the relation between grid, plate and filament.

“bayonet” type. The connections to the terminal pins are shown in Fig. 30.

**12. How the Audion Works.**—It is found experimentally that when a piece of metal is heated to the temperature of incandescence small particles of negative electricity, called *electrons*, are thrown off from it. This evaporation of electrons from the metal is called *thermionic emission* and is a phenomenon very similar to the evaporation of water particles from water which occurs at ordinary temperatures. The function of the filament in the audion is to send out

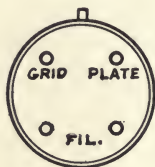

Fig. 30. — Illustrating connections on standard “bayonet” type audion base.

such particles, or as often stated, “to supply electrons.” We care very little about the nature of these electrons, what they are or how they are emitted; the important thing to be noted is that they carry electricity—negative electricity—and that moving from one place to another they constitute an electric (convection) current.

With this in mind, look at Fig. 31. This shows a filament which is heated by a current from the battery “A” and sends out electrons; and an electrode designated as the “PLATE” which is maintained at a positive potential with respect to the filament by means of the battery “B.” Both electrodes are to be regarded as being in a vacuum. Upon emerging from the filament the electrons find themselves in the strong electric field between the electrodes, and being negatively charged, move toward the plate under the action of the electric forces. This kind of attraction has already been noticed in Art. 2 (e) when the electric field was explored by means of a small charged particle. Or we may

account for this movement of the negatively charged particles toward the positively charged plate by simply remembering the teaching of our school-days: like charges repel, unlike charges attract.

The stream of electrons to the plate, as already stated, constitutes an electric current; and since the charge conveyed is negative, the *direction of the current* is opposite to that in which the particles are moving. The current flows

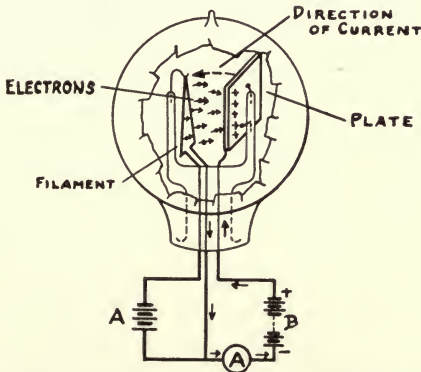

Fig. 31.—Current of electrons from filament to plate in a two-electrode tube.

around the plate circuit as shown by the arrows (Fig. 31) and is registered by the ammeter *A*.

Now if the plate potential is made negative with respect to the filament, that is, if we reverse the "B" battery, the electrons are repelled and very little or no current flows. The device thus acts as a rectifier permitting the passage of current in one direction and not in the other, and may be called a *thermionic rectifier*. These rectifiers have important applications in radio telephone circuits which will be described in Chapter V.

Consider now the effect of inserting between the positively charged plate of Fig. 31 and the filament, a third electrode in the form of a grid (Fig. 32). The construction of the grid is such that the stream of electrons is not completely hindered mechanically; a few of them do, of course, strike it, especially when its potential is positive. It has been observed that the electrons are attracted by a positively charged electrode and repelled by one negatively

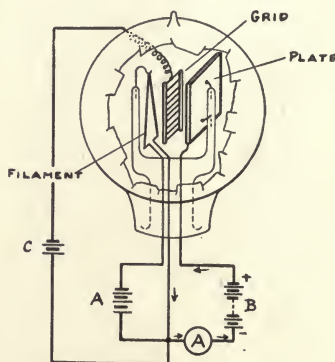

Fig. 32.—Illustrating insertion of grid to control the electron current to the plate.

charged. This principle is used to control the stream of electrons to the plate.

If the potential of the grid with respect to the filament is made positive by means of the battery "C," the electrons will be attracted, or rather their attraction will be increased, and an increase in the current to the plate will be indicated by the ammeter *A*. Conversely, if the grid potential is negative, the stream will be repelled and the plate current will be diminished. Thus the grid acts as a throttle to regulate the flow of electrons to the plate, and it can be

so designed that its throttling action is very great, that is to say, very small variations of its potential are sufficient to produce very marked changes in the plate current. On account of this the device is called an *amplifier*, and amplifies the small grid voltage variations.

**13. The Audion as an Amplifier.**—It is sometimes helpful to represent this action graphically, as is done in Fig. 34. Here we have a curve, called the *characteristic curve*, which depicts the relation between the current in the plate circuit,  $I_p$ , and the voltage between the grid and filament,  $E_g$ . The plate battery voltage and filament heating current are held constant. The greatest change in the plate current for a given change in the grid voltage occurs at the point marked "P"; consequently if the device is to be used as an amplifier the grid should be maintained at the voltage

(= -1.5 volts) corresponding to this point; then when the small variations are superposed they will have a maximum effect. A typical circuit in which the audion is employed as an amplifier is shown in Fig. 35. The a.c. voltage to be amplified is introduced by coupling through the *input transformer*,  $T_1$ , and impressed upon the grid. The grid is maintained at the point "P" in Fig. 34, that is, at the best part of the curve, by means of the battery "C." The magnified current is led out of the system through the *output transformer*,

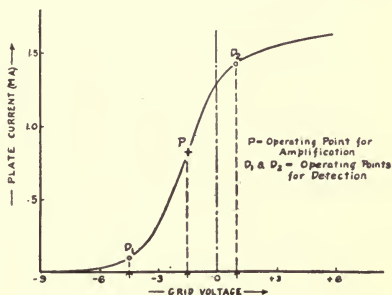

Fig. 34.—Typical characteristic curve of the audion showing relation between the plate current and the grid voltage, for constant plate battery voltage and filament current.

$T_2$ . Modifications of this scheme, wherein the transformers  $T_1$  and  $T_2$  may or may not appear, are employed; some of these will be described in later chapters.

**14. The Audion as an Oscillator.**—In virtue of the amplifying properties just discussed the audion may be used to generate alternating currents. This application is of great importance in radio telephony, both for sending and receiving; and its principle may be explained as follows:

Consider the case of the audion connected in Fig. 35 as an amplifier of a sinusoidal a.c. voltage impressed upon its grid. Corresponding to the sinusoidal variation of grid

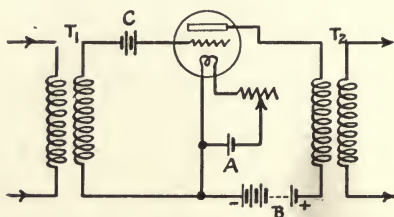

Fig. 35.—Elementary connections for using the audion as an amplifier.

voltage, the current in the plate circuit will undergo approximately sinusoidal variations and the amplified a.c. power which they represent may be made available in a load connected in the plate circuit (Fig. 36). In such a system we might put in one watt from the generator  $E$  and take out ten in the load. There is no violation of the principle of conservation of energy—we are not “getting something for nothing”—but the extra power is derived from the “ $B$ ” battery in the plate circuit. From this point of view the device may be looked upon, not as an amplifier, but as a converter of the d.c. energy supplied by the plate battery into a.c.



energy. The generator  $E$  is used for excitation in the same way that the small d.c. generator connected to the field of a large alternator is used for its excitation. In the case of the alternator the power is derived from the shaft which drives it, in the audion case from the "B" battery; in each the exciter plays a necessary but subordinate rôle. Any audion amplifier may be thus regarded, whether used for power amplification as supposed above, or for the magnification of the feeble currents in the receiving set. The point of view is more convenient and appropriate, however, when the generation of power is under consideration.

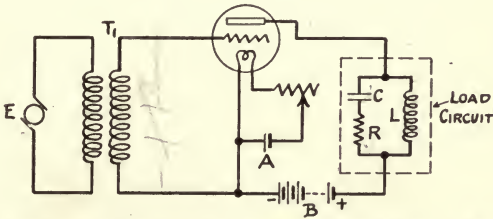

Fig. 36.—The audion in use as an a.c. power amplifier, or separately excited oscillator.

The power amplifier discussed above is often referred to as a *separately excited oscillator* and finds application for the generation of radio frequency currents for radio telephony. The details of this will be presented in Chapter IV under "Master Oscillator Systems."

If in the above system we put in one watt of power and can take out ten, let us say, it is perfectly obvious that one watt of this ten may be brought back into the grid circuit and used for excitation purposes, thus eliminating the exciting generator,  $E$ . The system then becomes *self-exciting* and may be used for the generation of a.c. power

directly. The modification of the connections of Fig. 36 for this is shown in Fig. 37, where the power for the excitation is brought back and introduced into the grid circuit by magnetic coupling. An audion connected in this way is said to

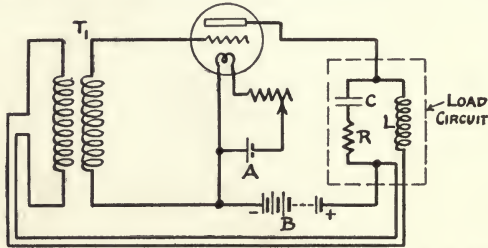

Fig. 37.—Method of bringing back power for the excitation of the grid circuit in self-excited oscillator.

be *retroactively coupled*, or *back-coupled*, and the process of bringing the energy back into the grid circuit is commonly called *feeding back*. Various methods of feed-back are employed, and the load circuit also takes a variety of forms, the most important of which will be described in Chapter IV. The essential principle in all of these arrangements is the same and the above explanation of it may be

made clearer diagrammatically as in Fig. 38. In this diagram the flow of power is traced. Coming originally from the "B" battery, or d.c. source in the plate circuit, part of it is absorbed by the load (for instance, by a radio transmitting antenna), the rest is dissipated in the audion itself. Once started, the energy travels around the vicious electrical circle shown, and the oscillations build up until the limit of the tube is reached.

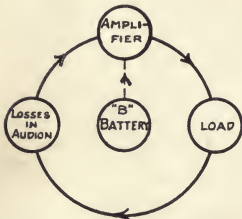

Fig. 38.—Diagram representing the flow of power in the oscillating audion.

in the plate circuit, part of it is absorbed by the load (for instance, by a radio transmitting antenna), the rest is dissipated in the audion itself. Once started, the energy travels around the vicious electrical circle shown, and the oscillations build up until the limit of the tube is reached.

The load circuit usually contains an inductance and capacity (as in Fig. 37) which determine the frequency of the generated oscillations. By properly proportioning these constants, currents of frequencies from a fraction of a cycle per second to thirty million or so cycles per second, may be generated. The function of the oscillator in the radio telephone system is primarily to supply radio frequency power to the transmitting antenna; it also has important applications in receiving.

**15. The Audion as a Detector.**—We shall now consider the operation of the audion in its other important rôle, viz., as a detector. The function of the detector in the radio telephone system is to demodulate the received signals (of radio frequency) and to translate them back into the low frequency currents which represent the original speech. This may be accomplished with the audion in three different ways, two of which will be described; the third is too complicated for inclusion in a book of this scope.

Let the device be connected as in Fig. 39. A sinusoidal a.c. voltage of radio frequency is impressed on the grid by the generator  $E$ , but now the "C" battery will be adjusted so that the grid potential is normally at either of the points  $D_1$  or  $D_2$  of the characteristic curve (Fig. 34). At these points the curvature of the characteristic is large and good operation as a detector will be secured. The reason for this will be seen from the following:

Figure 40 shows the effect an a.c. voltage on the grid has upon the plate current. The plate current variations are

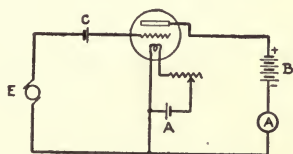

Fig. 39.—Showing audion in use as a detector.

no longer even approximately sinusoidal, as in the case of operation at the point "P" for amplification purposes, but are asymmetrical with respect to the normal current,  $I_0$ . It will be observed that the current loops are larger above than below, so that the *average plate current* has increased. The radio frequency variations have no effect upon the ammeter  $A$ , or upon a pair of telephones connected in the plate circuit, but the change in the mean plate current

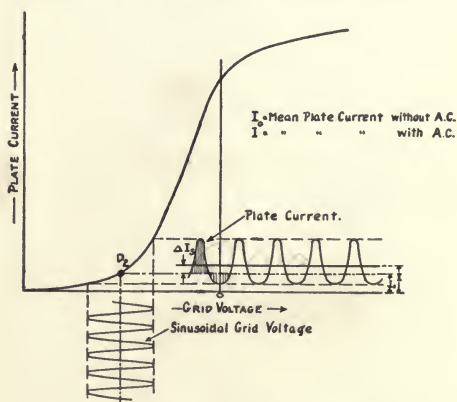

Fig. 40.—Showing variations of plate current caused by sinusoidal variation of grid voltage; rectification effect in plate circuit.

( $\Delta I_g = I_1 - I_0$ ) which they produce is immediately recorded. If the generator  $E$  is separated from the grid by a telegraph key, and its e.m.f. impressed in the form of dots and dashes, the ammeter  $A$  will be deflected every time the key is closed and the system could be used for telegraphy. But of greater interest is the effect of the more complicated radio telephone signal of the type of Fig. 28. This case is carried through graphically in Fig. 41 using the signal of Fig. 28 as a model. The mean plate current is now no longer constant, but varies roughly according to the modulations

of the radio frequency wave. This is shown by the heavy line curve in Fig. 41. This current, labelled "MEAN PLATE CURRENT (TELEPHONE CURRENT)," flows through the telephone receivers, whereas, on account of the high impedance offered to them, the radio frequencies do not. This is shown in Fig. 42, which is a photograph\* of the currents

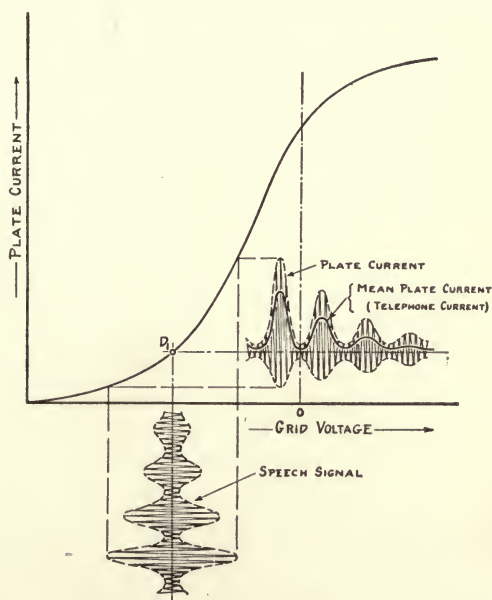

Fig. 41.—Illustrating detection of radio telephone speech signal (Fig. 28) by asymmetrical audion characteristic.

and voltages in a case of the detection of a signal of approximately sinusoidal modulation. The middle curve represents the modulated wave (the voltage impressed upon the grid); the lower curve shows the plate current variations; and the upper curve gives the current through the

\* For this photograph I am indebted to Mr. E. S. Purington of the Hammond Radio Research Laboratory, Harvard University.

telephones. The action of the telephone receivers in choking out the high frequency variations, and being activated by the lower frequency changes in the average plate current, is clearly brought out.

Thus the process of demodulation, or detection, consists in impressing upon the detector the modulated radio frequency wave which is rectified by the asymmetrical characteristic of the device giving a variation of the mean plate current corresponding in form to the modulation of the

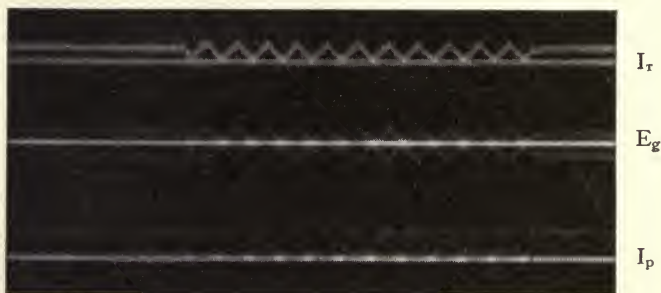

Fig. 42.—Photograph of the currents and voltages (circuit of Fig. 39) in a case of detection with the audion of a sinusoidally modulated wave.  $I_T$  = Telephone current;  $E_g$  = modulated wave (grid voltage);  $I_p$  = plate current. (Purinton.)

impressed wave. These low frequency variations of the plate current activate the telephone receivers, which then reproduce (somewhat distorted) the original speech.

The scheme of connections for detection by this method is shown in Fig. 43. Here the detector is connected across the inductance  $L_o$  of the antenna circuit and is activated by the voltage drop across it. Operation by this method is sometimes referred to as *detection without grid condenser*, with *grid bias* or *grid polarization*.

The second mode of operation is somewhat harder to

explain and to understand; in fact, a completely satisfactory explanation of the action has yet to be given. But in general the following may be said of it: This mode of operation is frequently referred to as *operation with grid condenser*, or more correctly *operation with grid impedance*, and the elementary connections for it are shown in Fig. 44. Here  $C_1$  is the grid condenser, usually of small capacity of the order of .0002 mfd.;  $R$  is the *grid leak* resistance (or an impedance) of the orders of from 500,000 to 2,000,000 ohms (at speech frequencies). By means of the battery "C," or by tapping

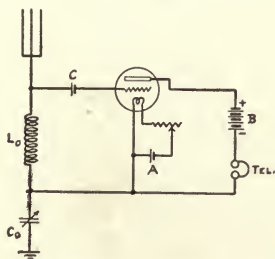

Fig. 43.—Simple receiving circuit using audion as detector with grid bias.

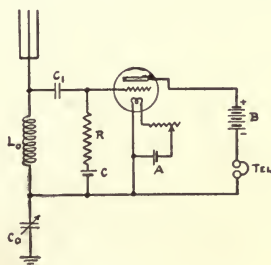

Fig. 44.—Simple receiving circuit using audion as detector with grid condenser.

in at some suitable point of the filament circuit, the grid is maintained at a positive potential. The reason for this is that operation now takes place by *grid circuit rectification*, that is, the rectifying effect just explained for the plate circuit, occurs in the grid circuit, and the rectified current flows through the grid circuit impedance, producing a voltage drop across it and thus lowering the average grid potential. This in turn affects the plate current, and produces in it variations characteristic of the original modulation. The telephone receivers reproduce the speech in the usual way.

## CHAPTER III

### ANTENNA CONSTRUCTION

**16. Antennæ for Sending and Receiving.**—From one point of view the antenna may be looked upon as the connecting link between the radio instruments and the ether. At the transmitting station it converts the radio frequency currents into ether waves; at the receiving station it intercepts such waves and translates them into radio frequency currents. It has therefore two principle functions: (a) to radiate r.f. energy, and (b) to receive it.

While the same antenna may perform both functions, its actions in the two cases differ, and in general the requirements for efficient radiation do not correspond exactly with those for efficient reception. The design and construction of the antenna depends therefore largely upon whether it is to be used for both sending and receiving, or for receiving alone. For instance, an efficient antenna for transmitting demands careful design and may be expensive to build, while for receiving purposes almost any kind of elevated conductor fairly well insulated, a bed-spring, tin roof, or a small coil, may be used with fairly satisfactory results. In other words, a good transmitting antenna will generally make a good receiving antenna, but the converse is not true, and an antenna that may give good results for receiving may be poor, or impossible, for transmitting.

Many amateurs, upon the threshold of their radio inter-



est, will want to make a modest beginning and equip themselves for receiving only. Naturally in this case a suitable antenna may be rigged up with little trouble and very cheaply; and detailed descriptions of such antennæ will be given later. On the other hand, there is a group who have perhaps served their apprenticeship as receiving station operators and have become sufficiently interested to want to do some "talking" of their own; for the benefit of these the paragraphs dealing with the design and construction of antennæ for transmitting have been included. It will be understood that no very detailed instructions can be given, for the choice of location and even of the form of the antenna itself, are questions which must be decided on the merits of each situation. All that can be usefully attempted here is to exhibit some representative forms, to indicate the desirable features to be secured and to give such details of construction as are independent of the choice of the antenna's location and other local conditions.

**17. Description of the Various Types.**—It can be shown theoretically, by means of the principle of similitude, that the best type of radiator is a highly conducting sphere, so the amateur who installs a silver hemisphere 90 feet in radius can boast of having the utmost in antennæ. This highly efficient but very impractical type of antenna is shown at (a), Fig. 45. The next type is derived geometrically by pulling out the sphere from the pole and making an ellipsoid of revolution as at (b). This is virtually the simple vertical wire antenna with which we have already become familiar, and may be considered the most efficient *practical* form. It is, however, not too practical, for in order to secure most efficient radiation an antenna should be operated at

its fundamental wave length (equal to four times the height in this case), and must therefore be high, demanding supporting masts which are both inconvenient and expensive. An antenna of this type designed to radiate most efficiently a wavelength of 200 meters would be about 164 feet high! Hence for practical reasons it will be desirable to modify (b) so that shorter masts can be used. The best modification is shown at (c) and consists in capping the antenna with a circular "top" made out of a number of wires radiating from the down-lead and having their ends joined by a cir-

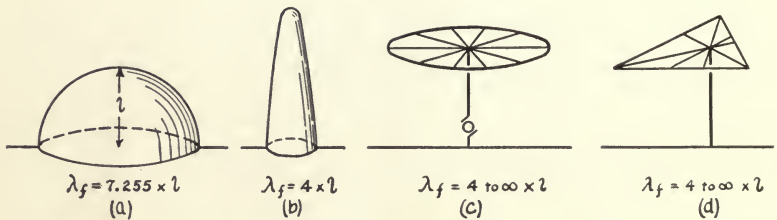

Fig. 45.—Illustrating evolution of practical form of antenna (d) from most efficient radiator (a).

cular jumper. In this form the fundamental wavelength is considerably greater than four times the height, so that shorter masts can be used. There is, however, this objection to a circular topped antenna: that it requires a circle of masts, so that while they are shorter, many of them are required and the question arises as to whether much has been accomplished in point of economy by this change.

(a) **Triangular Flat-top.**—A more economical form is shown at (d), Fig. 45, which represents a triangular flat-top that requires but three masts for its support. This form is not much inferior electrically to its predecessor and is undoubt-

edly the best practical structure, giving high radiation efficiency (when properly designed) with a low cost. The merit of this antenna has been recognized for years by the engineers of the United States Navy and has been adopted by them as a standard type for medium and high power stations. It has also been used extensively abroad. The

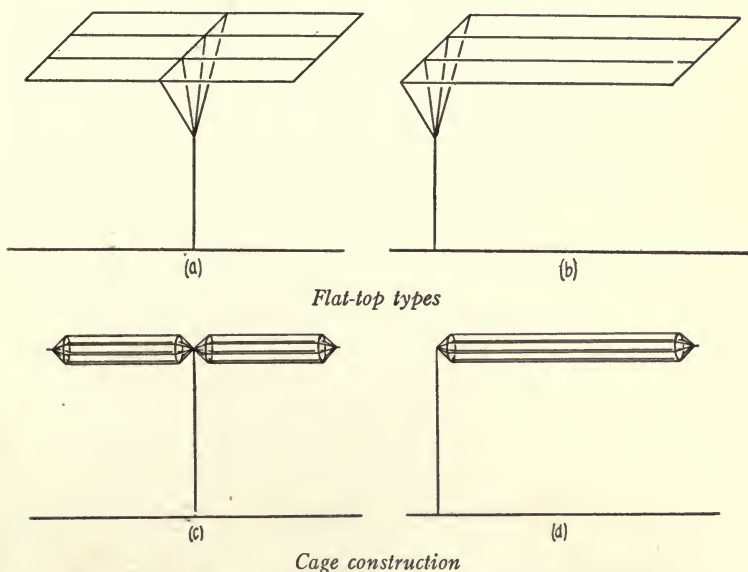

Fig. 46.—Illustrating inverted "L" and "T" type antennæ.

amateur who has plenty of space available and who is willing to spend a little money in pursuit of the utmost in efficiency will find this antenna of great interest.

(b) "T" and Inverted "L" Types.—The next important modification of the flat-top to secure still greater economy is shown at (a) and (b), Fig. 46. Two types are exhibited, in both of which the flat-top is rectangular and can be sup-

ported by two masts. At (a) the down-lead, or *lead-in* as it is called, is taken from the middle; at (b) it is taken from the end. The form (a) is slightly superior to (b) electrically. These are commonly designated as the "T" and *inverted L*" types respectively, and have found great favor for amateur as well as for general low power use, chiefly on account of their convenience and low cost of construction.

(c) **Cage Construction.**—In flowing along the multi-wire flat-top of this type of antenna the high frequency currents have a tendency to crowd toward the outside wires, and these wires carry more than their share of the current. This is termed the *edge effect* and increases the resistance of this portion of the antenna. While the increase is not extremely important on account of the smaller current densities that exist normally at the free end of the antenna system, the effect may be avoided entirely by making all the wires outside wires by a form of construction shown at (c) and (d), Fig. 46. This is called the *squirrel-cage*, or simply *cage*, type of top (and lead-in as well) and while giving in the usual form slightly less capacity than the flat-top is yet to be preferred for its low resistance properties. In cases where a large capacity is desirable, as for instance with the higher powered sets, two of these cages may be mounted in parallel as shown in Fig. 47. If the cages are not too close together this will yield a large increase in capacity without appreciably spoiling the uniform current distribution among the separate wires of each cage, and is a very desirable design. The lead-in in these, as well as in any of the antennæ shown, may advantageously be likewise in the form of a cage of possibly small diameter (about 8 inches) containing 6 or 8 wires (see Fig. 50).

(d) **Special Types.**—We have traced above the evolution from the most efficient but most impractical antenna to the cheaper and more practical forms of Fig. 46. There are, in addition, certain hybrid types which do not fit in well in

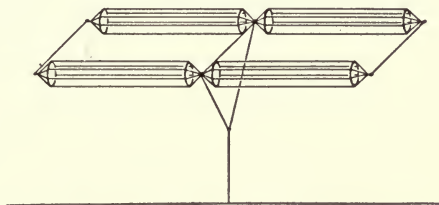

Fig. 47.—Showing cages mounted in parallel to secure greater antenna capacity.

this developmental scheme, but which are important and well worth description.

At (a), Fig. 48 is shown a modification of the hemispherical antenna of (a), Fig. 45. It consists of a plurality of wires and is excited by exciting all of the wires, or by exciting the

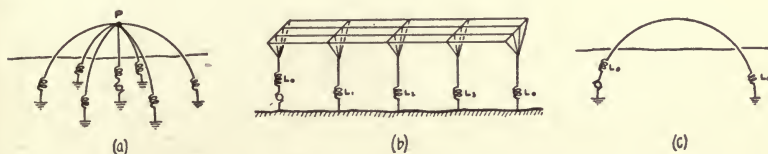

Fig. 48.—Special types of antennæ: (a) Symmetrical multiple antenna; (b) Alexanderson's multiple antenna; (c) loop antenna.

central lead-in as shown. The tuning and frequency are adjusted so that the current node resides at the pole *P*, otherwise the efficiency is lowered. Even if erected over an imperfectly conducting earth this antenna may still be made very efficient by burying a circular metal cylinder directly

under the bases of the component wires, the diameter of the cylinder being the same as that of the antenna, and the ground connection of each wire is made to the cylinder. The central lead-in is omitted and the system excited by exciting each of the load coils. In this form the antenna is very nearly as efficient as the spherical antenna from which it is derived.

Mr. E. F. W. Alexanderson has proposed an arrangement similar to this in which the wires are arranged in a straight line at (b), Fig. 48. This is called the *multiple-tuned* antenna, and is less efficient than the symmetrical form (a) for two reasons: (1) the ground currents cannot be distributed so uniformly as in the case of (a), and (2) the system will develop current vortices (*i. e.*, circulating currents in the flat-top which radiate in a useless direction) unless very carefully tuned. In fact, it can be shown theoretically that this antenna when erected over an imperfect earth is no more efficient than any one of its component down-leads regarded as a simple antenna. Thus notwithstanding the extravagant claims that have been made, it is no better as a radiator than the simpler structures illustrated in Figs. 45, 46, 47 and is, besides, more expensive to build. Its principle advantage, that of yielding a low input resistance, is realized only with special forms of generators such as the high frequency alternator; for amateurs it has little more than a general interest.

If we remove all of the wires in (a), Fig. 48 but two, there is obtained a simple type of antenna which is sometimes referred to as a *loop antenna*. This is shown at (c), Fig. 48 and has no particular advantages for amateur transmission, but is sometimes useful for receiving (see Art. 38). The

system may be so excited that it has remarkable directional properties.

A type of antenna which is becoming very popular with amateurs for 200 meter transmitting is called the *fan antenna* and is illustrated at (a), Fig. 49. By the use of the stay *A-B* the system may be supported by two masts. This is a very good antenna, but not *inherently* so good as the types previously recommended, Figs. 45, 46 and 47. It does offer a low resistance and high capacity; the trouble is that the capacity is too near the earth. However, *a greater efficiency with less care can probably be obtained with this antenna than any of the types yet described.* We have no

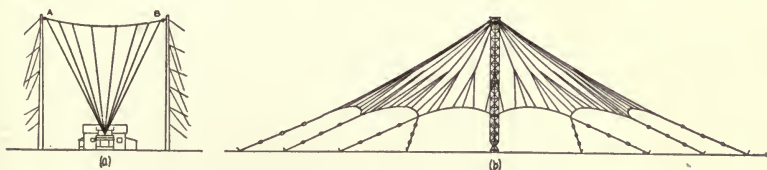

Fig. 49.—Illustrating “fan” and “umbrella” types of antennæ.

space to give reasons for this statement, preferring to use what we have in showing how the better qualities theoretically inherent in the other types can be practically secured.

Still another type is shown at (b), Fig. 49 and requires but one mast for its support. On account of its shape it is called the *umbrella antenna* and while successfully used by commercial companies, notably the Telefunken Company of Berlin, for high power work, is not considered particularly suitable for amateur use. It is obviously less efficient electrically than the triangular top type (d) of Fig. 45, and unless a lot of space is available for its erection will generally be inferior also to the “T” and inverted “L” types.

The above antennæ have been discussed particularly from the point of view of radiation. The special types for receiving will be taken up in Arts. 35, 36, 37, and 38.

**18. Requirements for Transmitting.**—All of the energy supplied by the power source to the antenna is not radiated by it. There are a great many ways in which some of this energy is dissipated and frittered away. The *merit* or the *efficiency* of an antenna system as a radiator may be taken as the ratio of the power radiated to the power supplied and the object of antenna design is to secure a system in which this ratio is as large as possible. The various losses, including that due to the radiation itself, may be represented by resistances, the values of these resistances being equal to the power lost divided by the square of the current at the point of the antenna (usually the base) at which the power is applied. The ratio just mentioned is then equal to the ratio of the radiation resistance to the total resistance of the antenna.

The most important sources of loss other than the only desirable loss, radiation, are as follows: (1) loss in the antenna conductors due to their resistance; (2) loss in the tuning apparatus (load coil and condenser in series with the antenna) due to its resistance; (3) loss due to heat developed in the earth (earth resistance) by currents returning to the lead-in; (4) loss due to imperfect dielectrics in the electric field of the antenna; (5) loss due to direct leakage through faulty insulators; (6) loss due to the induction of currents in neighboring conducting structures such as metallic poles, towers, guy wires, etc.; and (7) loss due to the formation of "corona" (brush discharge) on the wires. All these, with the possible exception of the last, are important in amateur



antennæ, and it is proposed to consider them in turn and to give practical instruction for keeping them as small as possible.

**19. Best Operating Wave Length in Transmitting.**—The resistance which represents the useful loss from the antenna by radiation varies inversely as the square of the wavelength, and directly as the square of the *effective height*. In a well designed antenna the undesirable losses enumerated above remain practically constant from the fundamental wavelength to a wavelength two or three times this, and the ratio of the useful loss (radiation) to the total power supplied is greatest at the fundamental wave length. Hence this is the wavelength at which best radiation takes place, and should be selected for transmitting. It will usually be necessary to insert in the antenna a load coil for the purpose of coupling the power circuit to it, but this should be kept as small as possible and its effect in raising the wavelength above the fundamental may be compensated for by inserting a series condenser having low losses. The *fundamental wavelength is not the wavelength at which maximum current will be secured*, but at which maximum  $I^2R_a$  ( $R_a =$  radiation resistance) is obtained. The operator is warned therefore not to be deceived by the antenna ammeter reading in estimating how well his station is radiating; this tells only a part of the story.

**20. Losses in the Antenna Conductors.**—The heat loss in the conductors of the antenna is the first source of loss listed above and while not particularly important unless the antenna is otherwise well designed and the other losses are small, nevertheless is additive and well worth taking the trouble to minimize. This can be done by using fairly

heavy conductors; a flat copper strip is best, stranded antenna wire being a good second. The latter is somewhat superior mechanically. Cage construction may be used in the top, the form of antenna shown at (c) and (d), Fig. 46 being a particularly good form to try this with; and should certainly be used in the entire lead-in. In this case the cage may be tapered as shown in Fig. 50. The object of this is to keep the capacity of the system as far away from the earth as possible; the capacity of the cage per unit

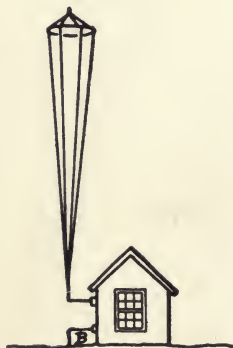

Fig. 50.—Tapered cage lead-in of low resistance.

length will increase rapidly with its diameter. We want the low resistance properties of the cage; but in the lead-in do not want its capacity. In the top, of course, the capacity is desirable, in fact more desirable proportionately than the low resistance properties, although both are needed. The portion of the lead-in, *B*, Fig. 50 (sometimes called the *ground-lead*) should not be neglected as it is here that the currents are heaviest.

A stout piece of copper strip, or several strands of the antenna wire in parallel, should be used.

**21. Losses in the Tuning Apparatus.**—While methods for reducing the resistance of the tuning apparatus will be described later when we come to consider the power unit, its importance is fittingly emphasized here. It would obviously be foolish to go to a lot of trouble to improve the conductivity of the antenna system unless as much attention were paid to the inductance coils and condensers in series

with it. And the importance of this increases with the improvement of the antenna.

**22. Losses Due to Earth Currents.**—The third source of loss, usually the most prolific in antenna systems, especially at short wavelengths, is the heat generated in the earth by the currents returning to or coming from the lead-in. Remembering that the heat loss is equal to  $I^2R$ , it is clear that the loss in any unit cube of the earth material goes up as the *square* of the current density at that point; consequently in order to keep down the whole loss the *concentration of current at any point* is to be avoided. The distribution of current depends upon the wavelength, conductivity and dielectric constant of the earth, as well as upon the geometry of the antenna. A symmetrical antenna will give a better distribution and consequently a lower earth resistance than one which is

not symmetrical; in other words, the circular topped type of (c), Fig. 45 will be superior to either of the types (a) and (b), Fig. 46, from this point of view. The distribution in the earth is determined at long wavelengths mainly by the earth conductivity; at short wavelengths, by the dielectric constant (unless the conductivity is too high). For earth of average conductivity, the penetration into the earth decreases as the wavelength is shortened. The flow of current in a typical case is shown in Fig. 51. The current converges toward the lead-in and the current density is therefore greatest at this point. In the antenna system, the current

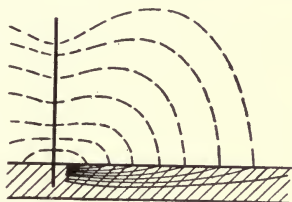
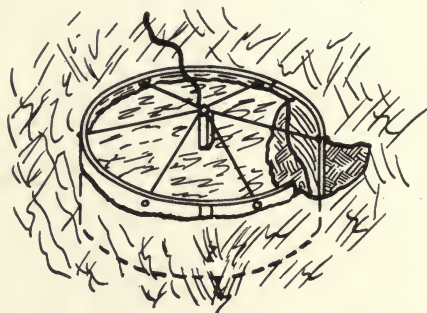

Fig. 51.—Showing flow of currents in the earth in a typical case of direct grounding (Zenneck).

flows by a conductive path up through the antenna conductors, thence by capacity paths to the earth, and finally through the earth to the lead-in. It is precisely the concentration of current here that causes most of the loss in the average grounding system. The loss may be diminished by reducing the current concentration, and this may be accomplished by providing a generous surface in the grounding electrode.

**23. Direct Ground.**—Such an electrode is shown in Fig. 52 and consists of a short circular cylinder of large radius. The



*Fig. 52.—Illustrating a very good type of direct ground with low earth resistance.*

proper depth is regulated by the penetration of current into the earth and for earth of not too poor conductivity and at 200 to 300 meters wavelength, a depth of 2 or 3 feet will be ample. The connection is made by means of a number of wires which converge to the approximate center of the circle and unless the cylinder is very deep, and in any case if it is more than 15 feet in radius, should be supported above the earth and not buried in it or laid upon the surface. The cylinder itself may be made up of galvanized-iron sheets, such as are used in the construction of small temporary

shacks. These need not be soldered together, but should overlap with no sharp edges protruding any distance from the body of the cylinder. A connection should be made to each sheet. They are better soldered, however, if it can be done. The ground is installed by digging a narrow circular trench under the antenna, not too far from the point at which the lead-in in the antenna diagrams, Figs. 45, 46 and 47, enters the earth. While it is not strictly necessary that the cylinder should be circular, this is the best form and no extreme departures which are likely to introduce sharp corners should be made.

This ground has recently been redescribed by Capt. H. J. Round, and is referred to in some circles as "Round's Round Ground." A better name would perhaps be the "Common Sense Ground," for it is older than radio itself, and was used by Fessenden\* as early as 1910, and has also been described by the Germans prior to that time and since. In modern times it has received its greatest support by the experiments of Dr. John M. Miller of the United States Navy Radio Laboratory.

**24. Counterpoise.**—There is another method for securing a more uniform distribution of the earth currents which is even superior and often cheaper and easier to install than the excellent ground system just described. This may be explained with the aid of Fig. 53 as follows:

Lay upon the earth a large metal disc and connect this to the lead-in, [Fig. 53 (a)]. The currents will now find a large conducting surface and on account of the large area and circular shape of the plate a fairly low resistance ground

\* According to Mr. J. W. Lee this ground was installed at the Brant Rock station, in the "Cut River Experiments."

will be obtained. There will probably be a slight concentration of current at the edges. This would make a very good ground and could be still further improved by extending its edges down into the earth as in the cylindrical ground system just described. The plate need not be on the surface, but may be supported above it as shown at (b), Fig. 53. The current flow is practically unaffected by this change and is completed through the condenser formed by the disc and the earth's surface. This system is found experimentally to yield a very low ground resistance, as the

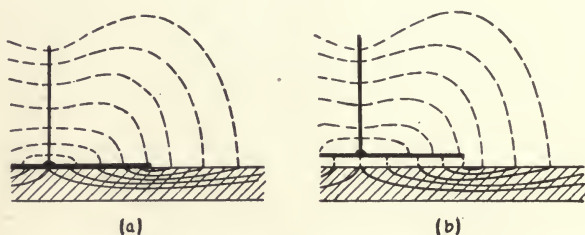

Fig. 53.—Illustrating equivalence of counterpoise (b) and surface electrode (a) in securing more uniform distribution of earth currents.

above reasoning would lead us to expect. From a practical point of view, however, a metal plate of this size is inconvenient and expensive. The advantages of the arrangement are not lost nor materially diminished if a net of wires is substituted for the plate, *provided* the wires of this network are sufficiently plentiful and they are not too far apart compared with the distance above the earth. Such an arrangement (b), Fig. 53, is called a *counterpoise* or *capacity ground*, and if properly designed and installed, is the most desirable and satisfactory type of ground for the amateur, especially in localities where the earth conductivity is poor. Con-

cerning the proper design and construction the following general remarks may be made:

**25. Design and Construction of the Counterpoise.**—The *area* of the counterpoise should be as large as possible since the distribution of earth currents is directly affected thereby. The exact *shape* is not generally important, but the best forms are the circular, elliptic, square and rectangular, in the order given. It should be placed as nearly under the antenna as possible and should extend well out beyond the antenna's projection on the earth. The *number of wires* should be as large as possible and the wires should be frequently bound together with cross jumpers. This will reduce to a minimum the generation of heat due to current vortices which form as a result of its possibly irregular shape and situation. The *height* of the counterpoise is governed by several considerations, the most important of which are the separation of the wires in the network, the evenness of the ground, the character of the vegetation with which it is covered, its conducting qualities, and the possible presence of ground water near the surface. If the height is small compared with the distances between the wires in the net, there will be a tendency for concentration of the current immediately under the wires. Thus the effect of laying the whole net right on the ground will be a decidedly poor ground system (at short wave lengths). The same thing is true if the net is buried. Bushes, grass, and other flora under the counterpoise constitute poor dielectrics and in order to make the volume of dielectric which they represent as small as possible compared with the total dielectric, the height of the counterpoise should be increased when they are present. A similar remark holds for any type of

poor dielectric. Also the height of the counterpoise should be uniform, that is to say, if there is a small eminence on the earth's surface the capacity at this point will be larger per unit area than in any other point of the area and the currents will head toward the path of lowest impedance; there will then be a concentration with corresponding increased loss in this section. The effect of small irregularities is reduced by increasing the height. From this point of view and also from that of poor dielectrics in the field, a counterpoise with a radio shack installed under its active area is decidedly poor design *unless* the method described later, Art. 25, or some similar device, is used to rectify the situation by redistributing the earth currents. Perhaps the most important single thing, and the most prolific cause of mediocre results in many counterpoises, is its *support*. The counterpoise is a condenser and should be treated with the same respect. Nondescript wooden stakes of all degrees of conductivity, wet rope, poor insulators, etc., should not be permitted in the intense electric field which exists between the counterpoise and the earth and extends some distance beyond its margin. The short poles used for its support should be placed at a distance from the margin equal to several times its height, and a good grade of porcelain or glass should be used for the insulation. The 17-inch porcelain insulators described later (Art. 29) in connection with the antenna insulation are recommended here.

The above precautions and desirable features have been incorporated in the design of a typical counterpoise system shown in Fig. 54. This may serve as a model in planning a counterpoise for any special situation. More detailed specifications would be of no particular value on account



of the wide variation of conditions likely to be encountered by the readers of these pages. For fairly even ground covered with short grass, a height of 2 or 3 feet will be adequate; for uneven ground or ground covered with bushes

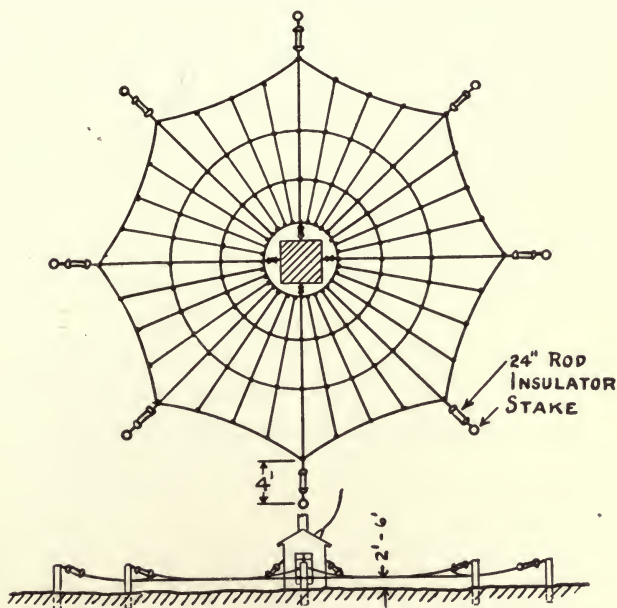

Fig. 54.—Model counterpoise system in which the design suggestions of this article have been incorporated.

and undergrowth, heights two or three times this will be necessary for best results.

In no circumstances should the counterpoise be directly grounded at one or two points, for there will then be a rush of current to these places which will defeat its whole purpose. The only way to ground the counterpoise would be to bury a circle of plates at its periphery, thus making

a very large direct ground of the type described in the last section. A direct ground may, however, be associated with a counterpoise by other means, as follows:

**26. Combination of Direct Ground with Counterpoise.**—The combination of the counterpoise described above with the single direct ground is frequently desirable. Cases of this arise from the necessity for: (1) grounding the d.c. high voltage source with certain types of audion trans-

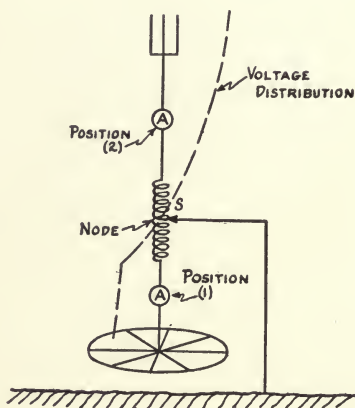

*Fig. 55.—Showing a method of combining direct earth and counterpoise to reduce earth resistance.*

mitting circuits when using the counterpoise, and (2) for redistributing the earth currents in the case of a counterpoise which either through unfavorable physical conditions, lack of space, etc., or faulty design, is not operating with a sufficiently uniform distribution. A very convenient method for this, which has frequently been reinvented and re-described, but which dates back to the radio station at Spanishtown, Gibraltar (1911), is shown in Fig. 55. The

direct ground should be in that part of the earth where there is either not enough current or too much, and should be constructed with the same care that would be taken if it were to be the only grounding means employed. If the ground tap  $S$  is placed at the point of the system where the voltage with respect to earth is a minimum (called a *voltage node*), it will have very little effect. This point can be determined experimentally by adjusting the tap until the effect of touching it to the antenna coil and removing it is a minimum, as indicated by the reading of the ammeter in "Position (1)" and the wavelength. If the antenna is operated above its fundamental the voltage node will reside upon the coil between the antenna tap and the counterpoise; if it is operated at the fundamental the voltage node will be found right at the antenna tap. Starting from this position the ground tap  $S$  is moved up or down until the reading of the ammeter in "Position (2)" is a maximum at the wavelength upon which it is desired to operate. (The adjustment of this tap will change the wavelength somewhat.) In the case of operation at the fundamental, or with high antenna resistance, it may be necessary to move several turns from the voltage node to secure sufficient voltage; in these circumstances it is advisable to neutralize the inductive reactance between the voltage node and the tap by means of a condenser of capacity about .005 to .007 mfd., otherwise the phase difference of the voltages at the two grounds will be too great for proper compensation. In experimenting with this circuit it is helpful to remember that the effect of the inserted e.m.f. is either to repel current from the direct ground, or to attract it, according to the direction of the e.m.f. The direct ground is therefore a remedial device

for changing the current distribution at the point of its application. It is obvious that the arrangement may be used also to secure an optimum distribution of current between two or more direct grounds.

Instead of the reading of the ammeter, a better method of adjustment is to use a nearby receiving station which can note the effect of each change upon the strength of the received signal. Ammeter readings in cases of this kind are not altogether trustworthy as an indication of the power radiated.

**27. Losses in Imperfect Dielectrics in the Electric Field of the Antenna.**—We come now to the fourth important source of loss in the antenna system. This is occasioned by the presence in the electric field of poor dielectrics in which losses by hysteresis, etc., occur.\* The part of the total antenna resistance by which this loss is represented increases linearly with the wavelength, or very nearly so. The antenna is virtually a condenser, in which the plates are separated by a distance which is large compared to their dimensions. Its electric field, therefore, extends for a considerable distance beyond its margin; thus not only are the dielectrics directly beneath it affected, but also those which might appear at first sight to be innocuously situated. Many types of poor dielectric are apt to be encountered. All wooden poles, spreaders, etc., used in the antenna's support, unglazed porcelain insulators (and indeed most in-

\*The importance of this type of loss was first emphasized by Dr. John M. Miller, at that time Assistant Physicist at the Bureau of Standards, and the reader is urged to consult his paper, "The Effect of Imperfect Dielectrics in the Field of a Radiotelegraphic Antenna," Scientific Paper of the Bureau of Standards, No. 269. Copies of this may be obtained from the Supt. of Public Documents, Wash., D. C.

sulators), rope, trees, buildings, shacks, etc., should be looked upon with suspicion. In estimating the effect of any dielectric in the field account should be taken (1) of its relative volume compared with the volume of the whole dielectric, and (2) of the strength (usually determined by its proximity to the antenna conductors) of the field where it is situated. Otherwise expressed, the effect will be determined by the capacity through the dielectric. Without going into any technical detail, the following general directions for avoiding losses of this type may be given.

**28. Trees in the Antenna Field.**—Probably the most prevalent source of dielectric loss in amateur antennæ is the proximity of trees, large bushes, etc. It is common practice, for instance, to use a tree for the support of one end of the antenna, usually the end farthest from the transmitter—the worst end. This practice, while very excusable from the point of view of convenience, cannot be too strongly condemned electrically. If a tree *must* be used, the active part of the antenna should terminate some distance from it, and not in its foliage; this will reduce the loss somewhat. But whether used for the support of the antenna or not, and even if fifty feet away from it, trees are deleterious and to be avoided if possible. This is particularly important with a type of antenna having very little flat-top capacity.

**29. Insulation of the Antenna System.**—Many amateurs (and “engineers,” too, for that matter) design the insulation of their antennæ apparently as if the only thing to be demanded of an insulator is that it shall insulate. But careful measurements of dielectric loss reveal that there are “insulators and insulators.” From this point of view we shall demand of an insulator that in addition to its being one, it



arrangement may be used also with wood spreaders; and in this case the wires should be wrapped around the spreader and *joined electrically to the suspension bridles A B C D*. An alternative scheme is shown at (b), Fig. 56, which has for its object keeping the wooden spreaders out of the intense electric field which exists close to the antenna wires. The cross jumper tends to reduce the electric force at the ends of the wires, which is desirable with wooden spreaders. The strain insulator should be chosen with care. The best insulator known to the writer for the low powers used by amateurs is a 17-inch porcelain rod insulator of the type shown in Fig. 57. They are rather more costly than the common



Fig. 57.—Sketch of 17-inch porcelain strain insulator.

garden variety of insulator, but are well worth the extra expense if the antenna is otherwise good.

Metal rings are recommended for the construction of the cage types of antenna (Fig. 46), although many amateurs use wooden barrel hoops. Brass or copper tubing is suitable and may be bent without flattening by first filling the tube with sand or melted sulphur. Metal plugs may be used in making the joint, and should be securely pinned or soldered in place. There is little danger of eddy currents in these rings. When wooden rings are employed the wires should be electrically connected to the bridle wires, as in the case of the wooden spreader. This type of construction is illustrated in Fig. 58.

When the antenna is operated at its fundamental wave-

length the voltage increases rapidly from the load coil to the free end; and for that reason the above precautions with respect to dielectrics are especially important near the free

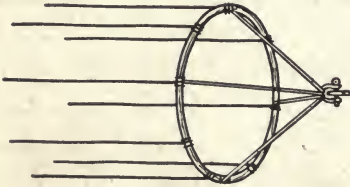

Fig. 58.—Cage antenna construction using metal rings or wooden barrel hoops.

end. But when any considerable amount of inductive loading is used, the voltage is more uniformly distributed and the entire electric field of the antenna, down to the load coil, is strong; consequently care should be taken with the whole system, from the load

coil itself, lead-in insulator and lead-in, to the end of the antenna. A very good and inexpensive lead-in insulator may be made out of a sheet of window glass as shown in Fig. 59. The glass may be drilled with the broken-off end of a triangular file, kept well lubricated with kerosene. The threaded rod and lead bushing should be inserted and locked in place immediately after drilling to prevent the internal strains from cracking the plate.

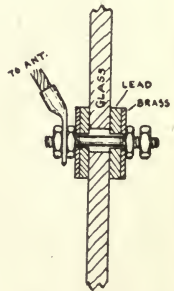

Fig. 59.—Illustrating inexpensive lead-in insulator with low losses, made from a sheet of window glass.

**30. Losses by Induced Currents in Masts and Guy Wires.**—The reader has already been advised to keep the masts as far away from the antenna as possible. This applies to metallic as well as to wooden masts. In

the latter case the purpose is to reduce the dielectric losses; in the former to minimize the flow of induced currents and the losses due to them. Metallic masts made up of sections



of wrought-iron pipe of decreasing size are very easy to build, cheap and convenient in every way; in addition, they present a very business-like appearance. In erecting such a mast do not dig a hole in the earth and slip the bottom of the mast into it, and do not bury it in concrete, but secure a number of good glass or porcelain insulators (telegraph line insulators will do), and, after bolting a flange and plate to the bottom of the mast as in Fig. 60, insert three of these insulators between the plate and the concrete or other supporting base. This will provide good insulation

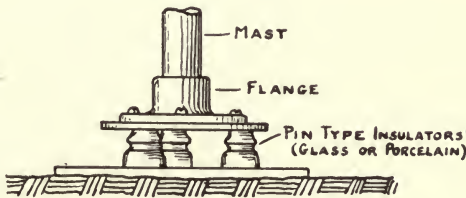

Fig. 60.—Showing method of supporting and insulating metallic masts to reduce dielectric and heat losses in them.

for the mast; then if it is to be grounded it can be done properly, with the aid of the direct ground of Art. 23.

There will be induced currents in the metallic guys as well as in the mast. Each guy should therefore be broken up into short lengths of 10 to 20 feet by means of porcelain egg insulators of familiar type. Remember that the mast with its guys is really a small antenna system, excited by the main antenna, in which all the losses enumerated for the main antenna, including radiation, will occur; hence it should be given its proportionate amount of care, especially in the matter of insulation.

Whether the masts should be grounded or not is still a matter of controversy. The question is a hard one to answer directly. If the insulation at the base is good, and there is no appreciable dielectric loss there, perhaps it had better be insulated. In any case the only satisfactory way to settle this question is by appeal to experiment; a distant receiving station can be requested to note the effect of grounding and insulating the masts. The reading of the ammeter in the main antenna circuit will be increased by grounding the masts; but this has no special significance and does not indicate that the radiation has increased. In fact, this may happen if the radiation has been reduced. So the observations should be made at the distant receiver.

**31. Telefunken Method of Reducing Losses in Masts.**—A modification of a method which is claimed to reduce the losses in metallic masts is shown in Fig. 61. This is due to the Telefunken Company of Berlin and is described in German Patent No. 300,782 (September 15, 1919). The idea is to impress upon the mast an e.m.f. of such magnitude and phase that will reduce the current flowing in it. This e.m.f. is regulated by means of the tap  $S$  on the load coil in the antenna circuit, and the inductance and capacity  $LC$  of the mast circuit. The wires  $AB$  should be run about 2 or 3 feet above the earth and connected to the masts at their bases. The masts should be insulated. The adjustment may be found tedious, since a distant receiving station should be used, and is very similar to that in the case of the combination of direct ground and counterpoise (Art. 26). In the original Telefunken diagram the antenna is connected to the mast, as shown by the dotted lines in Fig. 61. Theoretically there is not much gain to be expected with this

system, but several amateurs have reported favorably upon it. It is probably worth trying.

**32. Other Losses in the Antenna System.**—The losses due to direct leakage through insulators and corona are trivial and hardly worth discussion. The remedy in the first case is obvious; and the corona condition may be alleviated by increasing the capacity of the antenna, especially near the free end. It is not likely to be encountered with the low powers to which amateurs are restricted unless the antenna

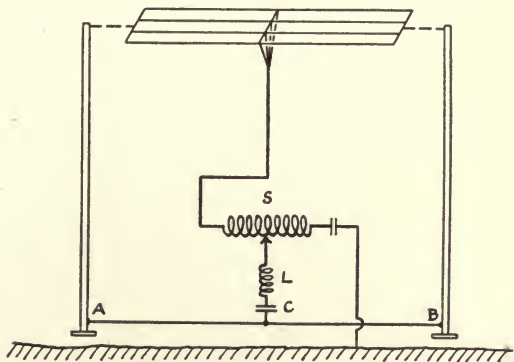

*Fig. 61.—Modified Telefunken method for reducing flow of currents in metallic masts and losses due to them.*

design is such that an unusually low capacity is obtained, as, for example, with a single wire of small diameter.

**33. Antennæ on Houses and Buildings.**—Up to this point we have considered the antenna system from the point of view of the amateur who has plenty of space at his disposal, and is in the fortunate position of being able to sit down and plan his antenna on a sound theoretical basis and to carry out his plans. In other words, we have cleared our conscience by outlining what we think should be done.

But there are many of us who, however enthused, do not feel justified, for instance, in cutting down a particularly fine tree simply because it is suspected of causing dielectric loss in our antenna system. And in other things as well, the



*Fig. 62.—Illustrating a high-capacity house-top antenna supported by one mast in which the restricted roof area is used to maximum advantage.*

theoretical “what should be done” must meet the practical situation half-way and effect a compromise with it.

Going still farther, consider the less fortunate city brother who has no space for his antenna except over the roofs of a row of houses. What shall be said to him? His whole vista is one of dielectric loss, eddy currents, and poor grounds; yet

he manages to live and to radiate, even if the row of houses must be heated by his losses in getting it accomplished. Obviously he needs sympathy and encouragement and not elaborate descriptions of cylindrical grounds 50 feet in diameter. Our advice in these circumstances is mainly non-technical: Do the best you can. But, in addition, the following remarks concerning house-top antennæ may be ventured:

Figure 62 shows an antenna of this type, in which the small roof space available is used to maximum advantage. This antenna has a high capacity and can be supported by one mast.

The chief disadvantage of these systems is that a great deal of material, dielectric and conducting, is directly under the antenna, in the most intense part of its field. The resulting dielectric and other losses will therefore generally be quite high. In the case of a house with a tin roof well bonded together electrically, there is sometimes an advantage in grounding the tin at its four corners, or in as many places as possible, by running a separate lead from each point of connection directly to the ground. The grounding of these leads should be well done; otherwise the supposed advantage may be turned into an increased loss. The ground-lead from the transmitting apparatus may then be connected to the tin roof. The effectiveness of this scheme increases with the amount of load in series with the antenna. This should not, however, be construed to mean that the antenna should be operated above its fundamental. Figure 63 illustrates this type of installation.

Good results have also been reported with counterpoises erected in the cellar, although this is hard to account for.

Other amateurs have used a moderately large cylindrical ground (Art. 23) in the back-yard with some success.

**34. Condenser Antennæ.**—The so-called *condenser antenna* is an ordinary antenna of small height and very large flat-top area, in which the ground is usually replaced by a counterpoise of about the same shape and size as the flat-

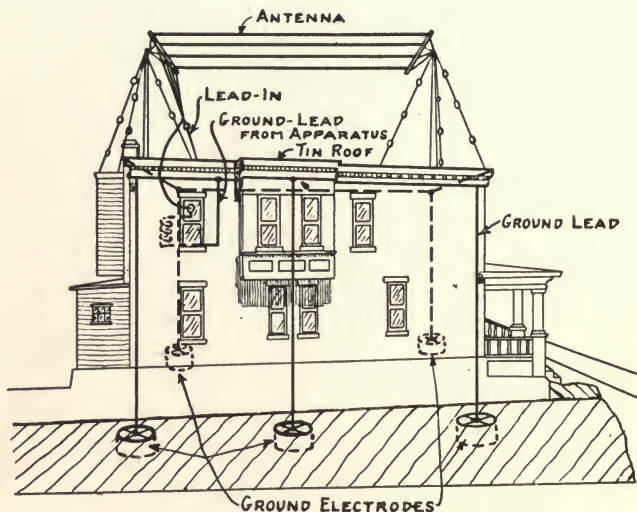

Fig. 63.—House-top antenna installed over well-grounded tin roof.

top. This type appears to be particularly suitable for house-top installation and is recommended for trial in such circumstances.\* The antenna is virtually a large condenser,

\* Mr. Malcolm Ferris, Expert Radio Aid of the United States Navy at Norfolk, Va., reported very good results in 1919 from an arrangement similar to that shown in Fig. 64. More recently Mr. Melville Eastham, of the General Radio Co., has experimented extensively with condenser antennæ on the roof of his plant in Cambridge, and by careful design has been able to radiate about as effectively with it as with the ordinary type of antenna. The properties of this antenna have been studied experimentally by Fessenden, and to some theoretical extent by Bennett.

one plate of which is the flat-top of the antenna (which should be of large area and contain a large number of wires) and the other is either a well insulated tin roof, or better, an auxiliary network of wires, or counterpoise, of as large area as space will permit. The field is largely confined to the region between the plates and there is consequently less dielectric

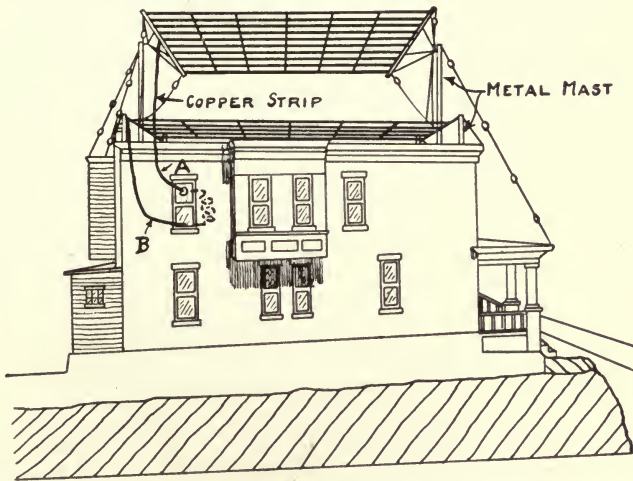

Fig. 64.—Illustrating "condenser type" of antenna especially suitable for house-top installation.

loss in the material under it and outside of its immediate neighborhood.

The success of this antenna depends upon securing a very low resistance in the system, principally in the lead-in, which should be made of a number of wires in parallel, or a generously proportioned copper strip. The length of the lead-in should be small and to secure this the apparatus may be installed on the top floor of the building as near to the antenna as possible. The load coil of the transmitter should

also have an especially low resistance. The reason for these precautions is that the radiation resistance of this type of structure is very low, consequently in order to radiate effectively with it the other losses should be proportionately low (Art. 18). A suitable antenna arrangement for house-top installation is shown in Fig. 64. The leads *AB* to the apparatus are two copper strips, about 1 inch wide,  $\frac{1}{16}$  inch thick, which are mounted about 1 foot apart with the aid of as few insulators as possible. Care should be taken with the insulation of these leads. The antenna is best excited with a form of oscillating circuit (see Chapter IV) in which magnetic coupling between the antenna coil and the audion is employed. The master oscillator system is particularly suitable, the Meissner circuit being the best substitute for this.

**35. Special Antennæ for Receiving.**—All of the types described above are good for receiving. We will consider here the special antennæ which may be used for this purpose, but which are not well adapted for transmitting. As stated at the beginning of this chapter, almost any kind of elevated wire may be used. In receiving the antenna losses are not nearly so important as in transmitting, for their reduction of the signal intensity is easily compensated by amplification, whereas in transmitting (on account of the large powers involved) a similar amplification would be expensive and prohibited beyond a certain point by the law restricting power input. Hence if the antenna is to be used only for receiving, the problem of its design has almost disappeared as such.

The special requirement of the receiving antenna not shared in transmitting is an immunity from the atmospheric



disturbances commonly called "static." The response of the antenna to static should be as low in proportion to its response to the signal to be received as it is possible to obtain. This characteristic or property of a receiving system is often spoken of as its *signal-static* ratio, and many special schemes and circuits have been devised for its increase. Fortunately for the amateur, the static problem decreases with the wavelength. A number of popular forms of antennæ suitable for receiving will now be described.

**36. The Single Wire Receiving Antenna.**—This consists merely of a single wire, insulated at both ends, from one end of which (or from the middle) a lead-in is taken to the receiving instruments. Its height is generally not important, at least over ground of not too high conductivity, and its length (including ground-lead) should be from 100 to 150 feet for 200 meter work. The fundamental wavelength of this kind of system is from 4 to 4.2 times its total length in meters. The insulation is not important; ordinary porcelain cleats will do; but lightning protection of the type prescribed by the underwriters should be used. (See Appendix.)

**37. The Beverage Wire.**—This modification of the single wire antenna, proposed by Mr. H. H. Beverage and described in United States Patent No. 1,381,089, has for its principal object the reduction of interference from static and other stations by means of its sharply directional characteristic. It consists of a single horizontal wire of length equal to the wavelength to be received (or an integral multiple thereof). One end of this is grounded through a resistance approximately equal to the "surge impedance" of the line (200 to 600 ohms for a line about 10 feet high, No. 16 A.W.G. wire,

at radio frequencies) and the other end is connected through an inductance to the ground in the usual way. The receiving apparatus may be coupled to this inductance (see Fig. 65).

The system has theoretically a well-defined directional characteristic and receives best from a direction toward the end grounded through the resistance, as shown by the arrow, Fig. 65. The inductance to be used at  $L_o$  may be of the order of 100 micro-henries for the 200 meter system portrayed. The chief merit of this antenna resides in its directional properties and the immunity it provides from static disturbances; a theoretical examination shows that as an antenna it has no special virtue, at least over ground of

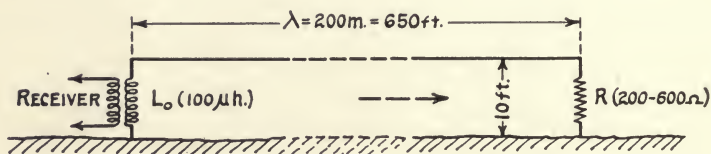

Fig. 65.—Illustrating "Beverage wire" suitable for 200 meter reception.

average conductivity. But the directional property may be frequently of great use; an example of this was furnished by the recent Trans-Atlantic Tests conducted by the American Radio Relay League, in which the antenna was employed with some absolute success in receiving the signals.

**38. Loop, or Coil, Antennæ.**—Another type of antenna, also with directional characteristics, which is fast becoming popular on account of the small space required for its installation, is the *loop* or *coil antenna*. It may be acknowledged at the outset that as an antenna the merit of this device is small, usually about 1 to 10 per cent. of that of the average elevated type; but since convenient amplifiers are

easily constructed, this objection is quickly vitiated by its features of compactness and portability.

The design of a good loop antenna is a complicated and difficult matter. We will confine ourselves here to a few general directions by following which a fairly satisfactory system may be built. The circuit for a simple loop is shown in Fig. 66. The circuit is tuned by means

of the variable condenser  $C$  and the amplifier or detector is connected across this condenser. The e.m.f. induced in such a coil when acted upon by the wave is nearly proportional to its area; and the voltage across the tuning condenser at resonance will also increase with this area. For best results the size of the loop should be increased until a single turn is formed which will resonate at the desired wavelength with 20 or 30 degrees of the variable condenser. This will make a large loop (see Table I, page 94), even for the short wavelength of 200 meters; and if it is too large, its size may be reduced and more turns added at the same time to maintain the same inductance. Data for square loops

of different sizes suitable for wavelengths from 180 to about 400 meters with a variable condenser of maximum capacity of .0006 mfd. are given in Table I. In making these computations it has been assumed that No. 18 lamp cord is used, and that the turns are separated by 2 inches. (There is some advantage in separating the turns on the coil, since then a larger number of them may be used for a given in-

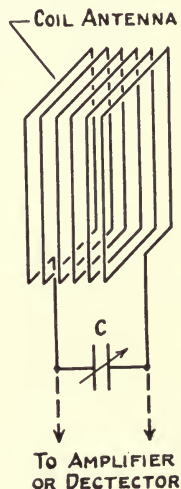

Fig. 66.—Showing connections of coil in use as a receiving antenna.

ductance and wavelength.) The wire should be chosen carefully. The best method is to wind on about ten No. 18 d.c.c. wires in parallel; this will make a flat stranded conductor of low resistance. Copper strip  $\frac{1}{4}$  inch by .005 or .01 inch is also very good. Ordinary lamp cord may be used if nothing better is at hand.

TABLE I

Data for Coils Suitable for Wavelengths from 180 to 400 m. with Condenser .0006 mfd. Capacity.

Side of Square Loop.	Number of Turns.	Induced E. M. F. (Relative).
35 ft.	1	19.8
17	2	9.3
10	3	4.8
7	4	3.1
5	5	2.0
3	7	1.0
$2\frac{1}{2}$	10	1.0

The loop receives best from directions parallel to its plane, and very poorly or not at all from directions at right angles to it. This property has been applied in making of it a direction finder to determine the directions of distant transmitting stations. It is also frequently of use for avoiding interference from other transmitters when their directions differ from that of the station whose signals are being received.

A loop antenna installation is shown in Fig. 67. Here the loop is rather elaborately constructed, and is of the type used by the United States Navy for direction finding pur-

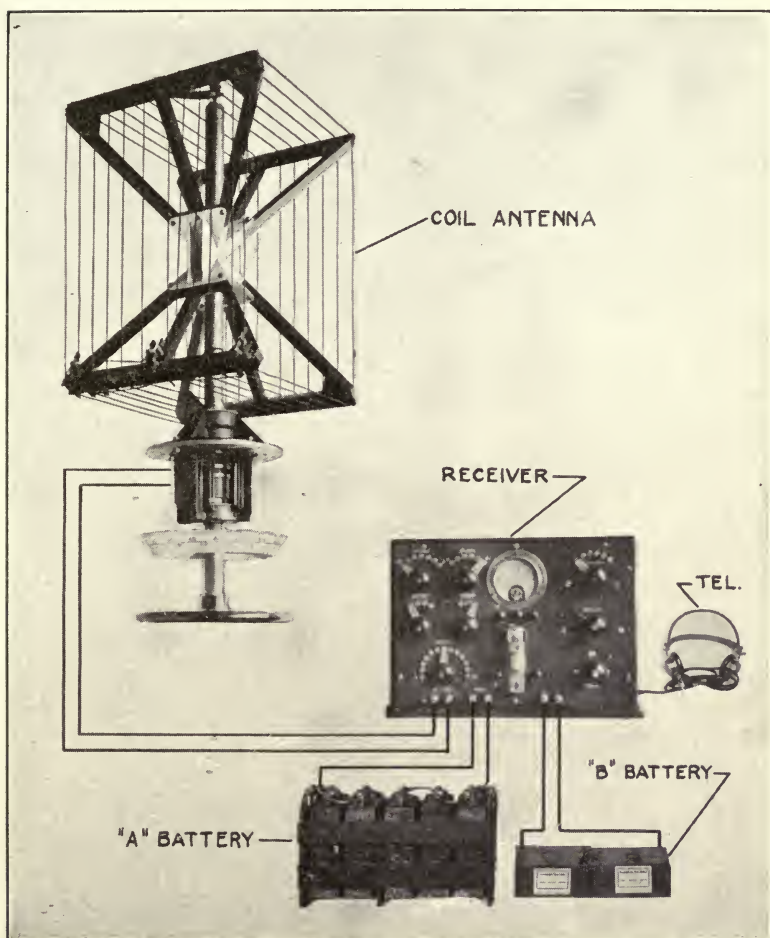

Fig. 67.—Receiving set with coil antenna of the type used by the United States Navy for direction finding.

poses. Very much simpler loops will do for ordinary receiving purposes.

## CHAPTER IV

### CONSTRUCTION AND OPERATION OF THE TRANSMITTER

39. Comparison of Methods for Generating R. F. Power with the Audion. Self-excitation and Master-oscillator Systems.—In Chapter II the use of the audion as a generator of alternating currents of any desired frequency was explained. Two schemes were considered; one in which the power for the excitation of the grid circuit was derived from the plate or output circuit of the same tube, and another in which a separate audion oscillator furnished the power for the excitation. The first of these was referred to as a *self-excited* system; the second, as a *separately excited* system or *master-oscillator* system (the small extra oscillator, or exciter, being referred to as the *master oscillator*).

With the self-excited audion the frequency of the generated oscillations is determined by the inductance and capacity of the circuit; in the case of the master-oscillator circuit it is of course that of the master oscillator, since the power tube simply acts as an amplifier in these circumstances and the inductance and capacity of its output circuit have little reaction upon the master oscillator. The power is supplied to the transmitting antenna, and for this purpose the antenna is coupled in some way to the output circuit of the tube; thus the constants of the antenna circuit affect the frequency of the oscillations in the self-excited system. In continuous wave (c.w.) work the re-

ception is accomplished by the "beat" method (see Chapter VI), consequently it is very important that the frequency of transmitting current remains constant. This does not apply to radio telephone work, for in this case ordinary detection is generally used. It is clear then that the effect of a change in the antenna constants, such as might be caused by a swaying antenna, or lead-in, is most pronounced in the self-excited oscillator and is frequently very troublesome. The master-oscillator scheme, on the other hand, is almost free from this objection for the reason just explained.

In addition to this the master-oscillator system is more convenient to work with, and the adjustment for maximum output for different wavelengths and antenna resistances is more easily made. When adjusting for maximum output in the self-excited system we must adjust for proper feedback and stability as well; or in other words, we are juggling with two oranges instead of one.

But from the amateur's point of view, in which the problem involved in the design of a transmitter is that of getting the greatest range for the least money, the master oscillator is objectionable in that it requires an additional tube. It is true that this master tube need only be large enough to supply the losses in its own oscillating circuit and those of the grid circuit of the main tube, and this is a fortunate feature; nevertheless the system has not become so popular with the amateur as the self-excited oscillator. This chapter will be devoted to both systems, but will reflect the greater importance of the circuits employing but one oscillator.

**40. Fundamental Circuits for Self-excitation.**—Such circuits are briefly referred to as *oscillating audion circuits*, and

the various types are usually designated by the names of their inventors. The fundamental principle is the same in all of them, and has already been explained. As we noticed, the circuit may be thought of as consisting of: (1) a power source, or plate ("B") battery; (2) audion; (3) load circuit (transmitting antenna); and (4) means for feeding back power to the grid circuit for its excitation. In order to bring out the fundamental form of these circuits all auxiliary apparatus, such as the filament heating source, biasing batteries, grid condensers, etc., will be omitted and the circuit will be indicated in three ways: one in which the connection of the load circuit and its form is emphasized; a second in which the actual feed-back connections are added (this is the form in which the circuits are usually drawn); and finally, the substitution of the actual transmitting antenna for the load circuit will be shown.

(a) **Meissner Circuit.**—This is the most general and flexible circuit, and is named after Dr. A. Meissner of the Telefunken Co. of Berlin. It is extensively employed by the General Electric Co. in their commercial transmitters, and has proved to be very convenient, particularly for aircraft installation where antennæ of widely varying characteristics are encountered. Referring to Fig. 68, it will be seen that the load circuit is magnetically coupled to the plate circuit of the tube; and to get the proper phase relation and easy adjustment for feed-back, or excitation, this circuit is likewise magnetically coupled. The chief merit of the circuit resides in its flexibility, and by means of the transformer the transfer of maximum power from any tube to any load (antenna) resistance can be arranged for. The adjustment of the feed-back is also conveniently made, and does not,



as in the case of the Hartley and Colpitts circuits, depend upon the voltage drop across a reactance in the load circuit.

(b) "Tickler Coil" Circuit.—If either of the transformers of the Meissner circuit are omitted, there is derived a form of

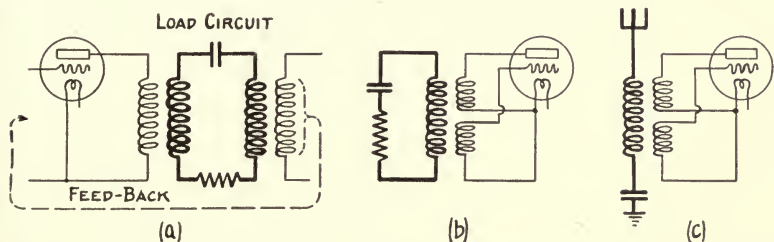

Fig. 68.—Schematic diagram of the Meissner circuit for obtaining self-excited oscillations with the audion.

circuit which has come to be known as the "tickler" coil circuit in continuation of a humorous reference made to the unnamed circuit by Mr. George H. Clark, of the Navy De-

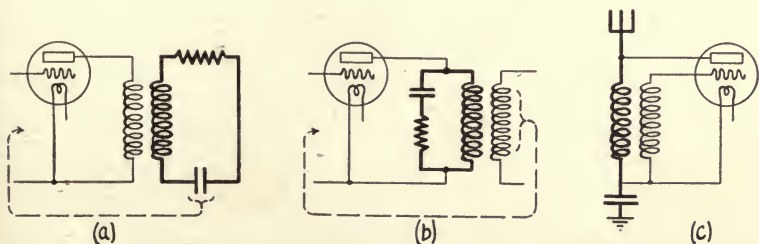

Fig. 69.—Schematic diagram of the "tickler coil" circuit for obtaining self-excited oscillations with the audion.

partment, some years ago. The two forms obtained by eliminating either coupling are shown in Fig. 69 (a) and (b).

At (c) the connection of the antenna to form (b) is shown. The reader will be able to devise the proper antenna connection in the case of form (a), so this is not indicated. These are obviously less flexible than the Meissner circuit from which they are derived. The first form (a) has been used extensively for generating oscillations, and for obtaining regeneration in receiving, an application to which we shall come in Chapter VI.

(c) **Hartley Circuit.**—In this circuit, invented by Mr. R. V. L. Hartley of the Western Electric Co., inductive coupling is entirely eliminated, the connection of the load circuit and

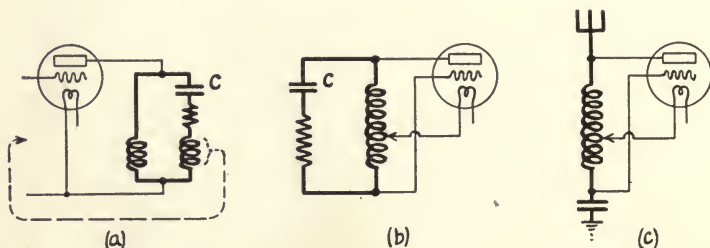

Fig. 70.—Schematic diagram of the Hartley circuit for obtaining self-excited oscillations with the audion.

the feed-back being made directly (Fig. 70). This circuit is not so flexible as either of the preceding, and is particularly hard to adjust for maximum power output with the low capacity antennæ used by amateurs at wavelengths of the order of 200 to 300 meters. It has, nevertheless, many useful applications in both the transmitting and receiving stations, notably as a master-oscillator circuit and as a local oscillator in "heterodyne" reception. In both of these applications it is possible to use the large capacity at *C* which the circuit demands for best operation.

(d) **Colpitts' Circuit.**—By exchanging the reactances in the Hartley circuit, that is, by exchanging the inductance and capacity, we derive a form of circuit, invented by Mr. E. H. Colpitts of the Western Electric Co., which is shown in Fig. 71. This circuit is a very popular one in amateur circles, and is deservedly so, for it is practically better adapted for the excitation of the low capacity antennæ. It will be seen from Fig. 71 that the antenna is substituted for the capacity  $C_2$  in constructing the actual transmitting circuit (c).

(e) **Armstrong Tuned Plate Circuit. Reversed Feed-back Circuit.**—The principle of this circuit is different from any yet described, in that the feed-back to the grid circuit

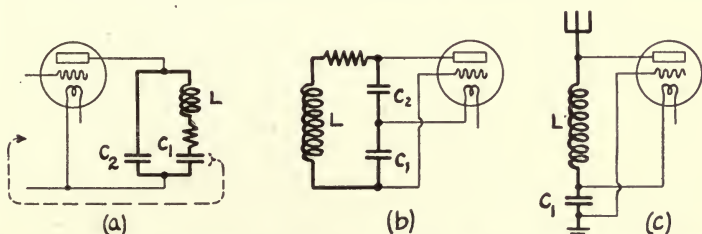

Fig. 71.—Schematic diagram of the Colpitts circuit for obtaining self-excited oscillations with the audion.

takes place through the tube itself by means of the small condenser formed by the grid and plate electrodes and their associated connections (batteries, etc.). This is one of the circuits invented by Mr. E. H. Armstrong, who first studied the feed-back action in audion circuits experimentally and gave a qualitative explanation of it. The most general scheme is shown in Fig. 72 (a). The frequency of the generated oscillations is determined principally by the constants of the grid circuit,  $L_g C_g$ , although the apparatus in the plate circuit does have some effect upon it. This is a

very valuable feature of the circuit, for by connecting the antenna to the plate circuit, as shown at (c), the change in its constants by mechanical swinging, etc., will have a smaller effect upon the wavelength emitted than in those circuits where it is directly associated with the circuit constants. Thus we secure to some extent the constant frequency advantage of the master-oscillator system which is so important in c.w. work. This circuit is sometimes referred to as the *reversed feed-back circuit*, although the

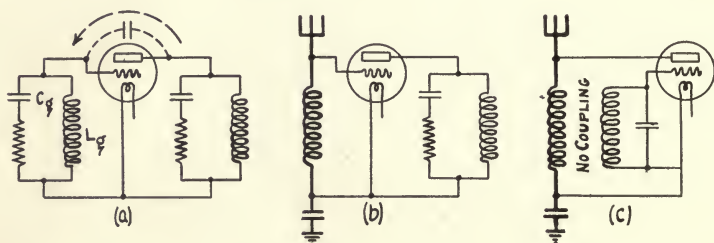

Fig. 72.—Schematic diagram of the Armstrong tuned-plate, or “reversed feed-back” circuit, for obtaining self-excited oscillations with the audion.

designation is a little fantastic. The mathematical theory\* of this kind of feed-back action shows that the feed-back effect increases as the wavelength is shortened, and depends also upon the grid-plate capacity, so that the action may

\* This was first formulated and published by Dr. J. M. Miller, then Physicist at the Bureau of Standards, and the interested reader is urged to consult his paper, “The Dependence of the Input Impedance of the Three-electrode Vacuum Tube Upon the Load in the Plate Circuit”; Scientific Paper of the Bureau of Standards, No. 351. (Copies may be obtained from the Supt. of Documents, Govt. Printing Office, Wash., D. C., for 5 cents.) Without having had knowledge of this publication the author examined the circuit theoretically (*Physical Review* (2), Vol. 15, p. 409, May, 1920) and published some curves which show the action very clearly.

often be improved and controlled by connecting an extra variable condenser of very small capacity (max. about .0001 Mfd.) between these electrodes, as shown by the dotted lines in Fig. 72 (a). This condenser should be capable of withstanding the high voltages existing between grid and plate during oscillation.

The Armstrong tuned plate circuit is particularly valuable for regenerative reception, which will be considered in Chapter VI.

**41. Electrical and Mechanical Data of Power Tubes Suitable for Amateur Use.**—Audions have been built in this country capable of handling as much as 10 k.w. of power; and tubes rated at 5, 50 and 250 watts are available on the market for amateur (experimental) use. Intermediate powers may be obtained by paralleling tubes of the same type. A general notion of the signalling ranges attainable with these powers, working by the c.w. method (not radio telephone), may be obtained from the following table:

TABLE II

APPROX. C.W. SIGNALLING RANGE WITH VARIOUS POWERS, USING MODERN RECEIVING APPARATUS

Power.	Antenna Current.	Range.
5 w.	0.45 amp.	400 miles
10 "	0.64 "	700 "
50 "	1.4 "	1500 "
100 "	2.0 "	2100 "
250 "	3.0 "	3000 "

The antenna currents are computed on the basis of an oscillator efficiency of 50%, for a 14 ohm antenna resistance

("T" antenna with flat-top total length equal to its height, operating 20% above fundamental). These currents are smaller than those obtained by the usual method of operation, *i. e.*, at a wavelength considerably higher than the fundamental, but as I have pointed out, represent more efficient radiation and will cover a *greater* distance with a given amount of power on *any* wavelength. The range estimates are very rough, and may vary several hundred per cent., but they will furnish the inexperienced reader with a basis for calculation. It is to be noted further that these are not radio telephone ranges, and require considerable abridgment to cover this type of modulation and reception.

A brief specification of the electrical and mechanical characteristics of the available types of power tubes may be useful to the amateur in planning his transmitter, and is contained in the following paragraphs:

*250-Watt Radiotron; UV-204.*

—The UV-204 Radiotron is, with the exception of the filament, very similar to the "Pliotron," or "P" tube developed by the General Electric Co. and supplied to



Fig. 73.—Type "P" power tube, prototype of the 250-watt Radiotron; UV-204.

the United States Navy during the war. It is the most powerful tube marketed for experimental purposes and is of the very best construction. The plate is of tungsten-molybdenum which, as is well known, possesses the useful property of absorbing gases when heated ("clean-up effect") thus improving the vacuum and not, like many other metals, spoiling it by the emission of occluded gases. For this reason the plate may be permitted to assume a bright red heat during operation without danger. The general rugged appearance of the tube is illustrated in Fig. 73, where the connections to the grid, plate and filament are also designated. A special set of contacts for mounting the tube are marketed, in which are also incorporated the safety gaps which will be referred to in Art. 45 on "Protective Measures." The tube may be mounted vertically; or horizontally in such a way that the plane of the electrodes is vertical, with the seal-off tip of the glass bulb pointing down. If the filament sags this will prevent its coming too close to the grid, a circumstance which would reduce its life, and in some cases result in the tube's destruction.

The important electrical and mechanical data of this tube are as follows:

*Electrical and Mechanical Data, 250-Watt Radiotron; UV-204*

Overall dimensions.....	5 x 14¼ in.
Base.....	Special end mountings
Voltage of filament source.....	12 V.
Filament terminal voltage.....	11 V.
Filament current.....	14.75 amp.
Plate voltage.....	2000 V. normal
Amplification factor.....	25
Plate resistance.....	4000 ohms min.
Plate current.....	.25 amp.
Watts output.....	250 normal

*50-Watt Radiotron; UV-203.*—This tube is very convenient



*Fig. 74. — Illustrating Radiotron; UV-203; a 50-watt power tube.*

for medium powered sets, and is illustrated in Fig. 74. It demands a special socket of the 4-prong bayonet type which can be easily constructed or obtained from the manufacturers, is preferably mounted vertically, but can be mounted horizontally with the long dimension of the elliptic plate vertical. The plate may be permitted to assume a bright red color in operation, and in special cases overloads and higher temperatures may be tolerated for short periods. For tubes in which the plate current is high, as in this case, the filament is best heated from an a.c. source; this will prevent one-half the filament from carrying more, and the other half less than its share of current. The important electrical and mechanical data of this tube are as follows:

*Electrical and Mechanical Data, 50-Watt Radiotron; UV-203*

Overall dimensions.....	2 x 7½ in.
Base.....	Four prong special
Voltage of filament source.....	12 V.
Filament terminal voltage.....	10 V.
Filament current.....	6.5 amp.
Plate voltage.....	1000 V. normal
Plate current.....	.15 amp.
Amplification factor.....	15
Plate resistance.....	4000 ohms
Watts output.....	50 normal



*5-Watt Radiotron; UV-202.*—These tubes are very popular for low-powered sets, particularly on account of their cheapness and the ease with which they may be operated in parallel to obtain higher outputs. They are also useful for power amplification at the receiving station for the operation of “loud speakers.” The base is a 4-prong bayonet of standard type, and the tube may be mounted in either a vertical or horizontal position. They are operated with the plate at a bright red heat and will stand considerable overloads. In many cases power outputs as high as ten watts may be obtained, but in these circumstances they should be operated with extreme caution and carefully watched for the development of portentous symptoms. The general appearance of the tube is shown in Fig. 75 and the chief electrical and mechanical data are as follows:

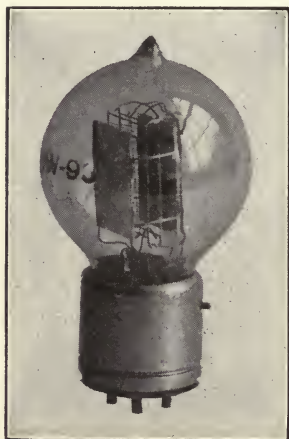

*Fig. 75.—Illustrating 5-watt Radiotron; UV-202.*

*Electrical and Mechanical Data, 5-Watt Radiotron; UV-202*

Overall dimensions . . . . .	2 1/8 x 5 in.
Base . . . . .	Four prong standard
Voltage of filament source . . . . .	10 v.
Filament terminal voltage . . . . .	7.5 v.
Filament current . . . . .	2.35 amp.
Plate voltage . . . . .	350 v. normal
Plate current . . . . .	.045 amp.
Amplification factor . . . . .	8
Plate resistance . . . . .	4000 ohms
Watts output . . . . .	5 normal

*5-Watt Western Electric "E" (V.T.-2) Tube.*—These tubes were made in accordance with the Western Electric Co.'s 1918 practice with coated platinum filaments, and on account of gas effects which have not been completely eliminated, must be operated with great care. At the rated heating current the filament will glow with a bright red color; and the plate should not be allowed to become hot, or at least to assume more than a barely perceptible red



*Fig. 76.—Western Electric 5-watt type "E" tube (CW-931 or V.T.-2).*

color. A plate ammeter is the best protection (this should itself be protected from being burnt out by a flash-over in the tube by a fuse made out of a piece of gold-leaf  $\frac{1}{16}$  inch wide), and should be watched to see that the plate current per tube does not exceed 40 milliamperes. In some cases bright spots will develop on the filament, and this may be generally regarded as a danger signal, portending flash-over and destruction of the tube. In starting to operate these

tubes after a period of inactivity it is advisable to first reduce the filament current and plate voltage about 50% and to bring the output up to full strength gradually. This is good practice in the case of any tube that has been idle, whether gas effects are suspected or not. The tubes are fitted with a standard 4-prong bayonet base and are mounted preferably in a vertical position. Their appearance is indicated in Fig. 76 and the chief mechanical and electrical characteristics are as follows:

*Electrical and Mechanical Data, 5-Watt Western Electric "E" Tube*

Overall dimensions.....	2 x 3¾ in.
Base.....	Four prong standard
Voltage of filament source.....	10 v.
Filament terminal voltage.....	7 v.
Filament current.....	1.35 amp.
Plate voltage.....	350 v. max.
Plate current.....	.040 amp. max.
Amplification factor.....	7
Plate resistance.....	5000 ohms
Watts output.....	5 max.

*Smaller Powers from Overloaded Receiving Tubes.*—In addition to the power tubes listed above, the use of overloaded receiving tubes is often resorted to for c.w. transmission and radio telephone work over very short distances up to fifty miles. Some of the tubes described in Chapter VI in connection with receiving apparatus are suitable for the purpose. Such a transmitter may be put together very easily and will appeal to the amateur who wishes to make his *début* and experience the thrills of two-way working with as little expense as possible. Any of the circuits described in later sections may be used, with suitable changes, of course, for the lower power; or the tubes may sometimes be

used in their native receiving connections by increasing the plate battery voltage.

**42. Collection of Transmitting Circuits with Detailed Description.**—We have given in Art. 40 a collection of the fundamental oscillating circuits suitable for transmitting, and in order to emphasize in these diagrams the form of the circuits, the auxiliary apparatus which is necessary in the practical applications was omitted. In this section a collection of circuits will be given, following closely the developmental scheme of Art. 40, but in which the actual connections and all auxiliary apparatus with the exception of the plate power source and the modulation system will be indicated. The various circuits will be accompanied by such details of construction and specification of proper circuit constants, as are considered useful. These data should be accepted by the reader suggestively, and represent averages with which he may begin his own experimenting. The wide variation in antennæ, and often in the power tubes themselves, render any more rigorous specification of doubtful value. Besides, the experimenter in many cases will want to make use of materials and apparatus on hand.

The power supply for the plate circuit and for heating the filament of the tube is a subject of sufficient importance and scope to require separate treatment, and this is attempted in the next chapter; so that in these diagrams the actual power connections will be omitted, the power sources being simply represented symbolically. This will simplify the diagrams a great deal.

# TRANSMITTING CIRCUITS

TRANSMITTING CIRCUIT NO. 1

MEISSNER ARRANGEMENT

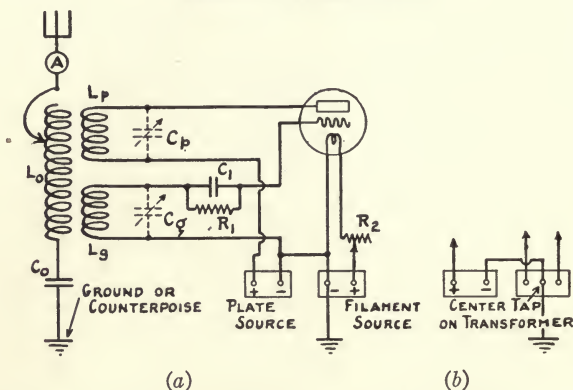

(b) Showing method of connecting to center-tap of filament transformer when using a.c. for filament heating.

DETAILED DESCRIPTION

Circuit Symbol.	Unit.	General Description.	Power.		
			5 w.	50 w.	250 w.
$L_0$	Antenna inductor . . . .	see Art. 44 (a)			
$C_0$	Antenna series condenser . . . . .	{.0003 to .003 mfd.}	8000 v.	8000 v.	8000 v.
$L_g$	Grid coupling coil . . . . .	4" dia., No. 22 d.c.c.	20 t.	15 t.	10 t.
$L_p$	Plate coupling coil . . . . .	4" dia., No. 22 d.c.c.	30 t.	30 t.	30 t.
$C_g, C_p$	Grid and plate tuning condensers . . . . .	variable .0005 mfd. max.	800 v.	1500 v.	3500 v.
$C_1$	Grid condenser . . . . .	.002 mfd.	1500 v.	1500 v.	1500 v.
$R_1$	Grid resistance . . . . .	{5000 to 10,000 ohms}			
$R_2$	Filament rheostat . . . . .	.....	2 a.	8 a.	16 a.
$A$	Antenna ammeter . . . . .	.....	0-2 a.	0-4 a.	0-8 a.

## CIRCUIT NO. 1

## MEISSNER ARRANGEMENT

This is considered the best circuit for reasons which have already been given. It is adapted as shown for either direct ground or counterpoise. The antenna series condenser is intended to counteract the effect of the coupling inductance  $L_o$  in raising the wavelength above the fundamental, and may be constructed of glass or mica as explained in Art. 44 (b). If a counterpoise is used and is of the proper capacity, it may be substituted for this series condenser; in this case its capacity is preferably large enough to resonate with an inductance in  $L_o$  barely large enough to secure efficient energy transfer to the antenna, at the fundamental wavelength of the antenna. The filament circuit may be grounded as shown; and when an a.c. step-down transformer is used to furnish the heating current, the center tap of the winding may be grounded and the grid circuit and negative terminal of the plate source may be connected to it. This will diminish the voltage fluctuation in these circuits. (See diagram at right of circuit.) Remember also that some part of the antenna coil  $L_o$  (the bottom when the system is vibrating at the fundamental) is at a high potential with respect to earth and there will be a capacity current through the small condenser formed by the windings of  $L_o$  and of  $L_g$ ,  $L_p$ , to ground. To avoid dielectric loss, the capacity of this path should be small, that is, the windings should not be too close together, and all unnecessary insulation and poor dielectrics should be eliminated. This is especially important if  $C_o$  is small. The condensers  $C_p$  and  $C_g$  are not necessary, but merely a convenience for tuning. Both  $L_g$  and  $L_p$  should be coupled to the antenna coil rather than to each other, especially when these condensers are used; this will reduce the tendency for a short wave oscillation in their circuits in which the antenna does not take part. The purpose of the grid bias resistance  $R_1$  and the grid condenser  $C_1$  is to increase the efficiency by regulating the grid voltage during the positive cycle, and to secure a proper average negative bias during oscillation. The circuit constants specified in the table are computed for an oscillator efficiency of 50% and for an antenna resistance of from 5 to 20 ohms at 200 to 300 meters.

TRANSMITTING CIRCUIT NO. 2  
"TICKLER COIL" ARRANGEMENT WITH INDUCTIVE GRID COUPLING

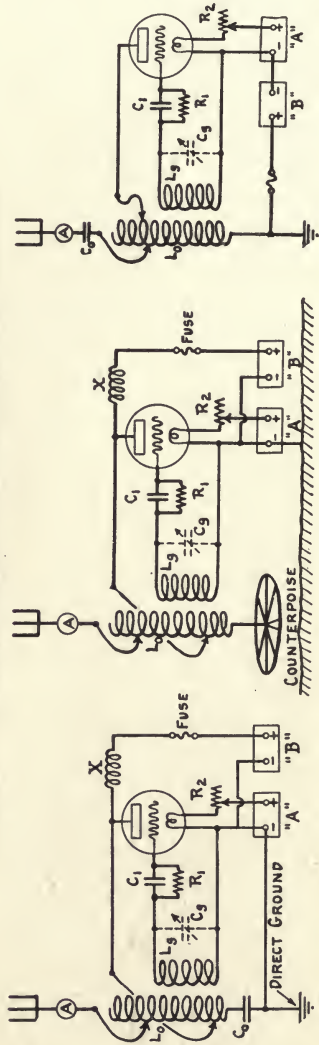

(a) Arrangements with filament grounded,  $L_0$  at plate (d.c.) potential. (b) Arrangements with  $L_0$  grounded, filament at plate (d.c.) potential. (c) Arrangement with  $L_0$  grounded, filament at plate (d.c.) potential.

DETAILED DESCRIPTION

Circuit Symbol	Unit.	General Description.	Power.		General Description.	Power.	
			5 w.	250 w.		5 w.	250 w.
$L_0$	Antenna inductor.....	Art. 44 (a)	50 w.	250 w.	5000 to 10,000 ohms	50 w.	250 w.
$C_0$	Ant. series condenser... {.0003 to .003 mfd.}		8000 v.	8000 v.		2 a.	8 a.
$L_g$	Grid coupling coil. . . .	4 in. dia., No. 22, d.c.c.	20 t.	10 t.	0.2 a.	0.4 a.	0.8 a.
$C_g$	Grid tuning condenser. variable .0005 mfd., max.		500 v.	500 v.	{ 3 m. h. See Art. 44 {(d)		
$C_1$	Grid condenser. . . . .	.002 mfd.	1500 v.	1500 v.			



## CIRCUIT NO. 2

## "TICKLER COIL" WITH INDUCTIVE GRID COUPLING

Three arrangements are shown, in which: (a) a direct ground connection is made, and power is supplied by connecting the plate across the series condenser  $C_o$ ; (b) a counterpoise is substituted for the antenna series condenser, the filament circuit being grounded to complete the path for the plate alternating current; (c) a direct ground is used, and the plate is connected across the antenna coil  $L_o$  instead of across the condenser  $C_o$ , or the counterpoise. (At the fundamental it makes no difference, except that the connections to  $L_g$  may need reversal, whether the plate is connected to  $L_o$  or  $C_o$ .) In arrangements (a) and (b) a fuse is inserted in the plate circuit to protect the antenna and plate circuit ammeters (latter not shown) in case the antenna is accidentally grounded at some point. In both (a) and (b) the antenna is at the d.c. potential of the plate supply, and great care should be exercised not to touch this part of the circuit without first disconnecting the plate source. The ground connection of the filament in (b) need not be elaborately made, as in the case of an antenna ground, for this carries only an alternating plate current of the order of a fraction of an ampere. Notice that the radio frequency choke  $X$ , whose function is to prevent the shorting of the output circuit by the plate source, is in parallel to the antenna condenser,  $C_o$ , or the counterpoise. Ordinarily the value assigned (3 milli-henries) will be resonant with this capacity at wavelengths from 2000–3000 meters, and unless the counterpoise capacity is unusually low there will be no troublesome resonance effects. In the third arrangement (c), the antenna circuit is at ground potential, but the filament circuit will be at the d.c. potential of the plate source; hence the same caution in touching this circuit should be observed as in the case of (a) and (b). About 60 micro-henries inductance will be needed between the plate tap and the ground in the case of (c); and a capacity of about .000185 Mfd. in the condenser  $C_o$ , or counterpoise, in the case of (a) and (b), for an antenna of 15 ohms resistance at 200 meters with any of the three types of audions described in Art. 41. This a very small capacity, and would seem to render the arrangements (a) and (b) inconvenient for short wavelengths with the tubes and antenna resistances we have contemplated in the design. This is, however, best determined by direct experiment.

TRANSMITTING CIRCUIT NO. 3

"TICKLER COIL" ARRANGEMENT WITH INDUCTIVE PLATE COUPLING

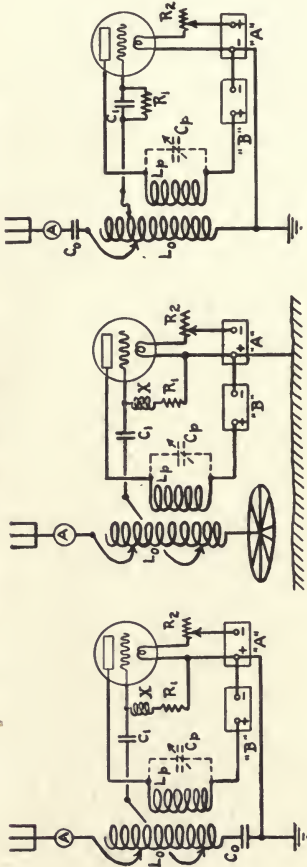

(a)

(b)

(c)

DETAILED DESCRIPTION

Circuit Symbol.	Unit.	General Description.	Power.			General Description.	Unit.	Power.	
			5 w.	50 w.	250 w.			5 w.	250 w.
$L_0$	Antenna inductor.....	Art. 44 (a)				{ 5,000 to 10,000 ohms	Grid resistance.....	5 w.	250 w.
$C_0$	Ant. series condenser..	{ .0003 to .003 mfd. }	8000 v.	8000 v.	8000 v.				
$L_p$	Plate coupling coil.....	{ 4 in. dia., No. 22, d.c.c. }	30 t.	30 t.	30 t.		Filament rheostat.....	2 a.	8 a.
$C_p$	Plate tuning condenser, variable.	.0005 mfd. max.	800 v.	3500 v.	1500 v.		Choke coil.....	See Art. 44 (d)	8 a.
$C_1$	Grid condenser.....	.002 mfd.	1500 v.	1500 v.	1500 v.		Antenna ammeter.....	2 a.	4 a.

## CIRCUIT NO. 3

## "TICKLER COIL" WITH INDUCTIVE PLATE COUPLING

These circuits are very similar to the preceding, differing in the use of inductive antenna-plate coupling instead of antenna-grid coupling. Three arrangements are shown in which: (a) a direct ground is used and the exciting voltage for the grid is obtained from  $C_0$ ; (b) a counterpoise is substituted for the antenna series condenser  $C_0$ , the filament being grounded to complete the circuit; (c) a direct ground is used, but the grid voltage is obtained from the antenna coil  $L_0$ . The purpose of the choke  $X$  is to keep the r.f. currents out of the circuit containing the grid biasing resistance  $R_1$ . Without this choke there is a loss of about 20 watts in a 5000 ohm bias resistance using the 250 watt tube (8%); by its use this loss is reduced to 0.5 watt (0.2%). In the case of arrangement (c), inductances of the orders of 30, 20 and 10 microhenries will be required between the grid tap on the antenna coil and ground, for the 5, 50 and 250 watt powers respectively (15 ohm antenna at 200 meters); while the corresponding capacities in the case of (a) and (b) required will be .00037, .00056 and .0011 mfd. For this reason *the arrangement (b) will generally be more suitable than the corresponding arrangement (b) of Circuit No. 2, for use with rather low capacity counterpoises.*

## TRANSMITTING CIRCUIT NO. 4

## HARTLEY ARRANGEMENT

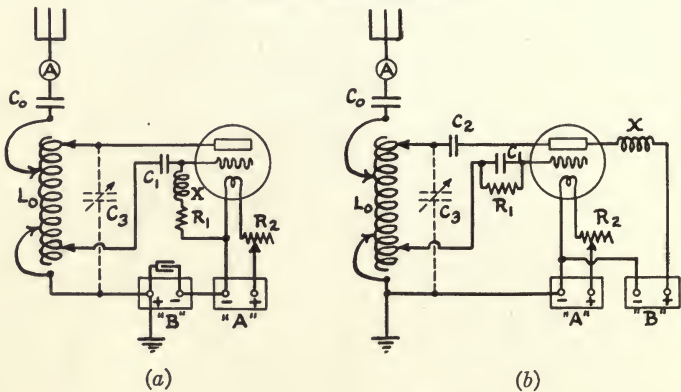

(a).—Filament at (–) plate (d.c.) potential. (b).—Both  $L_0$  and filament grounded.

## DETAILED DESCRIPTION

Circuit Symbol.	Unit.	General Description.	Power.		
			5 w.	50 w.	250 w.
$L_0$	Antenna inductor.....	see Art. 44 (a)			
$C_0$	Antenna series condenser.....	{.0003 to .003 mfd.}	8000 v.	8000 v.	8000 v.
$C_1$	Grid condenser.....	.002 mfd.	1500 v.	1500 v.	1500 v.
$R_1$	Grid resistance.....	{5000 to 10,000 ohms}			
$C_3$	Tuning condenser.....	variable, max. .0005 mfd.	1000 v.	2000 v.	5000 v.
$R_2$	Filament rheostat.....	.....	2 a.	8 a.	16 a.
$A$	Antenna ammeter.....	.....	2 a.	4 a.	8 a.
$C_2$	Plate isolation condenser.....	.002 mfd.	5000 v.	5000 v.	5000 v.
$X$	R.F. choke coil.....	see Art. 44 (d)			

## CIRCUIT NO. 4

## HARTLEY ARRANGEMENT

This circuit is not well adapted for use with a counterpoise when the filament supply is obtained from 110 volt a.c. mains through a step-down transformer, on account of the losses which would occur in the condenser formed by the transformer windings, this capacity being in shunt to that of the counterpoise. For the same reason the antenna series condenser is placed above the antenna coil as shown. In the arrangement (*a*) the antenna coil and its connections are at the d.c. potential of the plate source, and should be shielded from accidental contact. A condenser is required to bypass the antenna current around the plate source, and should be made of glass or mica and have a capacity of at least .002 mfd. Paper condensers will not do. The tuning condenser  $C_3$  serves to reduce the number of turns required between the plate tap and ground tap on the coil  $L_0$  (which may be quite large) and is a convenience. The radio frequency choke coil  $X$  is inserted to prevent the short-circuiting of the output circuit by the plate source. The proper inductance between the plate and ground taps on the coil  $L_0$  is about 60 micro-henries for all tubes (used singly, not in parallel); between the grid tap and earth about 40, 25 and 15 micro-henries for the 5, 50 and 250 watt tubes respectively; and just enough inductance should be included between the antenna and ground taps to secure maximum energy transfer.

## TRANSMITTING CIRCUIT NO. 5

## COLPITTS ARRANGEMENT

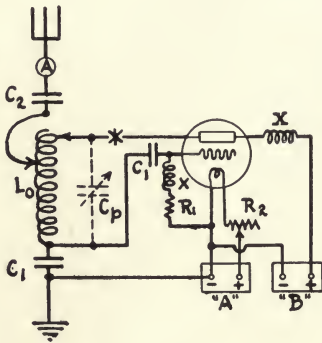

(a)

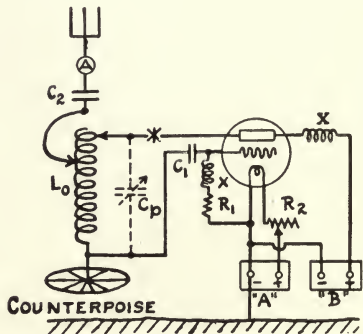

(b)

Filament grounded. Insertion of isolation condenser at (\*) will keep plate (d.c.) potential off  $L_0$ .

## DETAILED DESCRIPTION

Circuit Symbol.	Unit.	General Description.	Power.		
			5 w.	50 w.	250 w.
$L_0$	Antenna inductor . . . .	see Art. 44 (a)			
$C_1$	Grid input condenser . .	3000 v.	.003 mfd.	.0022	.0015
$C_2$	Plate output condenser .	.001 mfd.	5000 v.	5000 v.	5000 v.
$C_1$	Grid condenser . . . . .	.002 mfd.	1500 v.	1500 v.	1500 v.
$R_1$	Grid resistance . . . . .	{ 5000 to 10,000 ohms			
$C_p$	Plate tuning condenser .	variable, max. .0005 mfd.	750 v.	1500 v.	2500 v.
$R_2$	Filament rheostat . . . . .		2 a.	8 a.	16 a.
$A$	Antenna ammeter . . . . .		2 a.	4 a.	8 a.
*	Isolation condenser . . .	.002 mfd.	5000 v.	5000 v.	5000 v.
$X$	R.F. choke coil . . . . .	see Art. 44 (d)			

## CIRCUIT NO. 5

## COLPITTS ARRANGEMENT

The antenna is usually inserted in place of the condenser  $C_2$  in the Colpitts arrangement (see Fig. 71). In this connection it is possible to work only at wavelengths above the fundamental, for it is only here that the antenna acts as a condenser. At the fundamental it is a pure resistance, and below the fundamental, an inductance. So it is evident why many amateurs, using this circuit in its canonical form (Fig. 71 (c)) have not been able to realize the advantages of operation at the fundamental. It is possible to operate at the fundamental by inserting a condenser  $C_2$  in series with the antenna as shown. The antenna is a pure resistance and  $C_2$  provides the capacity effect essential to the circuit; otherwise the antenna short-circuits the plate output circuit. The exciting voltage for the grid is derived from  $C_1$ . Both of these condensers should be free from losses since they are in series with the antenna circuit. The tuning condenser  $C_p$  is a convenience, and is intended to reduce the number of turns between the plate tap and  $C_1$  on the antenna coil required for efficient energy transfer; with fundamental-operation where the antenna resistance is quite high, the required inductance is quite high also (70 micro-henries), so the use of this condenser is recommended. Arrangement (a) is suitable for direct ground; (b) for use with a counterpoise, the counterpoise capacity taking the place of  $C_1$ . The capacity of the average counterpoise will be somewhat lower than the values of  $C_1$  prescribed, so the grid voltage will be too high. It may be reduced by connecting the grid to a tap on the antenna coil instead of to the bottom of the coil as shown in the diagram. As the tap is moved from the bottom toward the plate tap, the voltage is reduced. If the proper capacity is available this will be unnecessary. The purpose of the choke  $X$  is as usual, to prevent the short-circuiting of the output circuit by the plate source. The antenna coil and its connections will be at the d.c. potential of the plate source; and to obviate this an isolation condenser of .002 mfd. capacity (5000 v.) may be inserted at (\*). An inductance of from 15 to 25 micro-h. will be required between the antenna tap on  $L_0$  and  $C_1$ , with the capacities specified. The data are based upon an antenna of 15 ohms resistance operating at its fundamental near 200 meters.





## CIRCUIT NO. 6

## ARMSTRONG TUNED-PLATE, OR REVERSED FEED-BACK ARRANGEMENT

The feed-back voltage for the grid is derived in this arrangement from the plate circuit through the small capacity between the plate and grid; the purpose of the small variable condenser  $C_m$  (max. capacity = .0001 mfd.) is to control it. This condenser may not be necessary, especially with the higher powered tubes having a high amplification factor. The wavelength of the generated oscillations is determined mainly by the constants  $L_g$ ,  $C_g$  of the grid circuit. The condenser of this circuit  $C_g$  is made variable for convenience in tuning. There is normally no coupling between the antenna coil  $L_o$  and the grid coil  $L_g$ .

Two arrangements are shown: (a) for use with direct ground; and (b) for counterpoise. In both the function of the condenser  $C_o$  is to give the antenna a capacity reactance at the fundamental. It will be noted that the second arrangement applies the method for combining a counterpoise and direct ground described in Art. 26, in which the direct-earth tap  $S$  is set approximately at the voltage node. The isolation condenser  $C$  keeps the d.c. voltage of the plate source off the antenna coil. The function of the r.f. choke-coil  $X$  is, as usual, to prevent the short-circuiting of the output circuit by the plate source.

TRANSMITTING CIRCUIT NO. 7  
MASTER-OSCILLATOR ARRANGEMENT

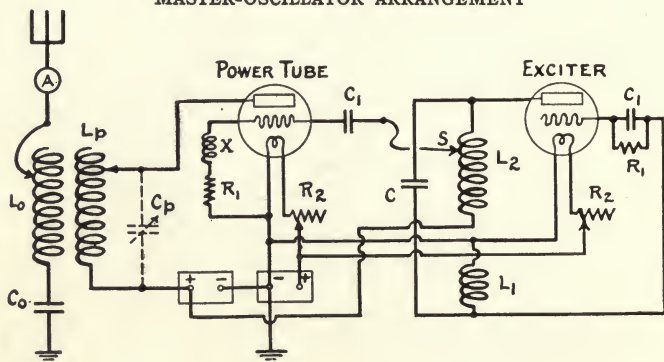

## DETAILED DESCRIPTION

Circuit Symbol.	Unit.	General Description.	Power.		
			5 w.	50 w.	250 w.
$L_0$	Antenna inductor . . . .	see Art. 44 (a)			
$C_0$	Antenna series condenser . . . . .	{.0003 to .003 mfd.}	8000 v.	8000 v.	8000 v.
$L_p$	Plate coupling coil . . . .	4" dia.	30 t.	30 t.	30 t.
$C_p$	Plate tuning condenser . . . . .	variable, .0005 mfd.	500 v.	1500 v.	3000 v.
$C_1$	Grid condenser . . . . .	.002 mfd.	1500 v.	1500 v.	1500 v.
$R_1$	Grid resistance . . . . .	{5000 to 10,000 ohms}			
$X$	R.F. choke-coil . . . . .	see Art. 44 (d)			
$C$	Oscillating circuit condenser . . . . .	.001 mfd.	2000 v.	4000 v.	8000 v.
$L_2$	Oscillating circuit plate coil . . . . .	6" dia.	7	9	10
$L_1$	Oscillating circuit grid coil . . . . .	6" dia.	7	5	4
$R_2$	Filament rheostat . . . . .		2 a.	8 a.	16 a.
$A$	Antenna ammeter . . . . .		2 a.	4 a.	8 a.

Note.—The construction of coils  $L_1$  and  $L_2$  is the same as that of the antenna inductor  $L_0$ . (See Art. 44 (a).)

## CIRCUIT NO. 7

## MASTER-OSCILLATOR ARRANGEMENT

This circuit is adapted for use with either direct ground or counterpoise, or with any combination of direct grounds and counterpoises by the method of Art. 26. The condenser  $C_p$  is a convenience for tuning and may be omitted if desired. An inductance of approximately 60 micro-henries will be required in  $L_p$  for any of the three types of tubes used singly, with an antenna resistance of 15 ohms at wavelengths from 200 to 300 meters and an oscillator efficiency of 50 per cent. The choke-coil  $X$  serves to reduce the grid loss by preventing the flow of radio frequency currents through the biasing resistance  $R_1$ . The master oscillator employs the Hartley circuit with two coils  $L_1$  and  $L_2$  shunted by a condenser  $C$ . This condenser may be made variable for convenience, or should at least be shunted by a variable condenser if precise adjustment of the wavelength is to be made. The coils  $L_1$  and  $L_2$  are constructed in the same way as the antenna coil as described in Art. 44 (*d*). For the excitation of the 5, 50 and 250-watt tubes the master-oscillator tube should be an overloaded receiving tube with 300 volts or so on its plate, capable of supplying 0.2 watt, a 5-watt tube, and a 50-watt tube in the respective cases. For a general discussion of this circuit and instructions for its adjustment see Art. 48.

**43. Comparison of the Transmitting Circuits.**—A critical and comparative examination of the circuits collected in the preceding pages may be undertaken either from the point of view of economy or from that of electrical performance and ease of operation and adjustment. A useful review would embrace both considerations. But since the various circuits differ only by a few coils and condensers, which are cheap or easily constructed, the economical features are of small importance and this survey may proceed upon an entirely electrical basis.

The possible exception to the last statement is the separately-excited or master-oscillator system, Circuit No. 7. Here, indeed, we are face to face with the economic matter of providing an extra audion tube, the value of which is but partly realized in actual antenna amperes. (The grid losses of the main tube are seldom over 10% in a properly operated system.) From an electrical viewpoint the circuit is superior to any of the self-excited type and a maximum of flexibility and freedom from frequency changes are attained with it. The latter feature is most important, of course, in the case of c.w. signalling. It is suitable for direct earth connection, counterpoise, and any combination of direct earth connections or counterpoises. Moreover, the transformation ratio can be easily adjusted for maximum power transfer from tube to antenna under conditions of widely varying antenna resistances and antenna forms, an adjustment which proceeds with almost no attention to the grid circuit. Every amateur who contemplates the installation of 50- or 250-watt tubes is urged to consider the advantages of this arrangement.

The Meissner self-excited circuit, Circuit No. 1, is in point

of flexibility a good second to the master-oscillator circuit, and from an economic point of view excels in not requiring an extra tube. It is adapted for almost any type of antenna, or antenna resistance, direct ground connection, counterpoise, etc., and is without doubt the best of the self-excited circuits for radio telephony. For c.w. work its chief drawback is that the frequency may be changed by a swinging antenna, and from this point of view only is it inferior to any other circuit. In these circumstances and for this method of communication, the Armstrong tuned-plate circuit is preferable to it.

Next in order of merit, for use with a counterpoise, the "tickler" coil Circuit No. 3 (*b*); Colpitts Circuit No. 5 (*b*); Armstrong tuned-plate Circuit No. 6 (*b*); and "tickler" coil Circuit No. 2 (*b*), are recommended in the order given. For direct earth connection, "tickler" coil Circuit No. 3 (*a*) and (*c*); "tickler" coil Circuit No. 2 (*a*); Armstrong tuned-plate Circuit No. 6 (*a*); Colpitts' Circuit No. 5 (*a*); and the Hartley Circuit No. 4, are recommended in this order. The arrangements in which the antenna coil and its connections are at the d.c. potential of the plate, Circuit No. 2 (*a*) and (*b*), and in which the filament is at this potential, Circuits No. 4 (*a*) and No. 2 (*c*) should be carefully operated. In many cases they may be made safe by means of an extra r.f. choke-coil and isolation condenser. The method will be gleaned from some of the other circuits.

**44. Construction of Apparatus.**—The descriptions of apparatus to follow are merely intended to serve as a guide, and fairly substantial departures from the specifications can generally be made with no danger of failure. When such

departures are likely to introduce trouble, a notation will be made to that effect.

(a) **Antenna Inductor,  $L_o$ .**—This inductor is inserted in the antenna circuit primarily to provide a means for transferring the power from the plate circuit of the audion to the antenna. It should be constructed so that it will introduce a minimum resistance into the antenna circuit; and this must be attained by reducing to a minimum the high frequency

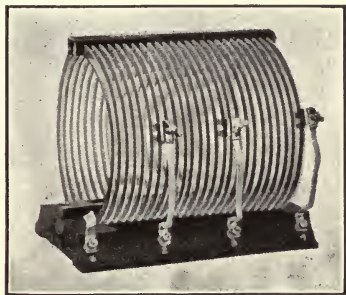

*Fig. 77.—Showing method of reducing dielectric losses by surrounding antenna coil and grid condenser with a grounded metal screen.*

resistance of the conductor, and the dielectric losses. We speak of dielectric losses because they are more important than is generally imagined. When operating at the fundamental, the part of the coil nearest ground is at a high potential (of the order of 1000 volts) with respect to earth, and when operating above the fundamental the top of the coil, as well, oscillates at a potential higher than that of the earth; hence there is danger of loss in poor dielectric paths both between the ends of the coil, and much more importantly, between the coil and the earth. To reduce the

latter loss it is advantageous to surround the inductor and the antenna series condenser  $C_o$  with a metal screen, which is grounded, and split vertically to prevent the flow of eddy currents. This will also prevent accidental contact with these parts of the circuits, which in many of the circuits are continuously at the d.c. potential of the plate source. Such a shield is shown in Fig. 77 and may be made of any piece of ordinary iron fly-screening, for there are no heavy

currents in it. The other type of loss, due to the high frequency resistance, may be kept low by the use of copper strip wound preferably flat in the form of a helix. A minimum of insulating material should be used in the support of this helix. Avoid winding the strip on insulating tubes, using rather two or three longitudinal stiffeners like the upper one in the helix shown in Fig. 78. An inductance sufficient for most purposes will be obtained with 30 turns of 6 or 7 inch diameter. Taps should be provided as indicated in some of the circuit diagrams. Certain of these circuits, notably the Meissner and "tickler" coil arrangements, require one or more coupling coils. These coils may be wound with a smaller wire because they do not carry heavy currents, and may be mounted inside the antenna coil, being conveniently arranged to be rotated so that the coupling can be adjusted. The proper way to arrange this mechanically will occur to the reader. A typical antenna inductor is shown in Fig. 78.



*Fig. 78.—Typical form of antenna coil for audion transmitting circuits.*

(b) **Antenna Series Condenser,  $C_o$ .**—The purpose of this condenser is generally to neutralize the effect of  $L_o$  in raising the wavelength above the fundamental, and since it is in the antenna circuit and carries the antenna current, should be designed to have low losses. A number of good condensers are on the market; those in which a good grade of mica is used are preferable. An inferior condenser in which the losses are somewhat larger, may be constructed from glass

plates coated with copper or tin-foil. The proper capacity will vary a great deal and must be determined experimentally. In the tables the limits of this variation have been indicated as .0003 to .003 mfd., these being considered adequate for most situations, and a condenser adjustable within this



Fig. 79.—Illustrating construction of glass-plate condenser.

range may easily be designed as follows:

The capacity in microfarads of a condenser made from  $n$  positive plates, and  $n + 1$  negative plates (see Fig. 79) is given by the following formula:

$$C = \frac{.000000365 A n \epsilon}{d}, \text{ (mfd.s.)};$$

wherein  $A$  = area of the conductor in sq. in.;  $d$  = thickness of the glass plates in inches;  $n$  = the number of positive plates (corresponding to which there are  $n + 1$  negative plates) and  $\epsilon$  is the dielectric constant of glass, usually about 6. Thus supposing we have a number of 5 x 7 inch glass plates at our disposal, of thickness = .12 inch (about  $\frac{1}{8}$  inch), which may be coated with tin-foil, 4 x 6 inches ( $A = 24$  sq. in.); the capacity per positive plate will be:

$$C = \frac{.000000365 \times 24 \times 6}{.12} = .000438 \text{ mfd.s.}$$

A condenser of 8 positive and 9 negative plates arranged so that various numbers of positive plates can be included in the circuit would probably cover the range required.

Other condensers in the antenna circuit, input condensers, etc., as well as the grid and by-pass condensers frequently indicated, can be constructed in the same way.



(c) **Variable Transmitting Condensers.**—In many of the transmitting circuits variable condensers are a great convenience, especially in the situations indicated by the dotted lines in the diagrams. Most of the variable condensers on the market are designed for receiving purposes and will not stand the high transmitting voltages. There are, however, a few types which may be adapted for this purpose by increasing the breakdown voltage. These are provided preferably with large plates, half of which may be removed, thus doubling the distance between plates and quartering the maximum capacity of the condenser. If the use to which the condenser is to be put demands a higher capacity than this and a higher breakdown voltage, the condenser may be filled with a good grade of transil oil (or any kind of pure oil, castor oil, Russian white mineral oil, etc.) from which the moisture has been removed by filtering through blotting paper. This will increase the breakdown voltage from 2 to 5 times and the capacity in the same ratio. It also increases the losses, so should not be used unless absolutely necessary.

(d) **Radio Frequency Choke-coil, X.**—This may be wound with No. 28 enameled, silk or cotton covered wire, in a single layer coil of about the following dimensions:

Diameter.	No. Turns.	Length of Winding.
2"	500	8 $\frac{3}{8}$ "
3"	250	4 $\frac{1}{8}$ "

It is advantageous, if a suitable condenser is at hand, to shunt this coil with a capacity so chosen that the circuit is in resonance with the transmitting wavelength; it will then offer an impedance greater than the coil alone. A variometer of sufficient range is also useful here and may be adjusted

so that with its own distributed capacity the above condition is satisfied. The operator will be able to tell when the proper choking action is being obtained.

(e) **Grid Resistance,  $R_1$ .**—Resistances of from 5000 to 10,000 ohms are suitable for most purposes with single tubes. When tubes are operated in parallel it will be necessary to either reduce the resistance and increase its current-carrying capacity, or to provide a separate resistance for each tube (see (a) and (b), Fig. 80). Resistance units in very convenient form are marketed, and in view of the low prices at which these are offered it hardly seems worth while to try to make them. If, however, the reader wishes to attempt this a resistance suitable for small tubes may be constructed as follows:

Procure a short length of glass tubing of the type used for mercurial barometers, of inside diameter about 2 mm. with a stout wall about  $\frac{1}{8}$  inch thick. This is to be closely packed with lampblack and provided with metal end-caps for making connections. If a resistance bridge or "megger" is at hand the proper length of tube and closeness of packing for any desired resistance can be determined; otherwise make the tube about 4 inches long for 10,000 ohms resistance.\* Carbon, graphite and carborundum rods may also be found useful. In all these forms and in the lamp-black resistance, the current-carrying capacity is low and regular wire-wound resistances may be necessary with the higher powered tubes. But for 5-watt tubes, in which the grid current should not exceed 5 milliamperes, they should be entirely satisfactory.

\* This construction is described by Mr. A. J. Funk in the November, 1920 issue of *Q S T*, p. 20.

**45. Protective Measures.**—Both the audions used for power generation and the meters used in their circuits are costly and cannot easily be repaired in case of accident to them. For this reason proper precautions should be observed in connecting up the circuits to see that every wire is in its proper place before the power is applied. It is always advisable in putting a circuit into operation, either for the first time or after a period of inactivity, to reduce the voltages at least 50% and to bring the output up to its full value gradually.

The use of a plate circuit milliammeter during the adjustment of the transmitter, so that the mean plate current may be kept within safe limits, or to indicate the rise of plate current if for any reason the audion stops oscillating and is improperly biased, or to test the modulation in the case of a radio telephone installation, is advantageous and recommended. This meter should be protected from being burnt out by excess current due to accidental grounding or flash-over in the tube or its safety gap, by means of a small fuse. A suitable fuse may be made by pasting some gold-leaf on a sheet of writing paper, and cutting it up into strips of the proper size. The width of these strips will vary from  $\frac{1}{4}$  to  $\frac{1}{8}$  inch depending upon the current to be interrupted.

There are many times when the voltages in the transmitting circuit will rise momentarily to values considerably higher than have been contemplated in the design of the apparatus and tubes. Cases of this arise from: c.w. signalling with a key in the grid circuit when the voltage across a d.c. generator in the plate circuit, for example, may rise to the breakdown point of the insulation; and in ordinary telephone modulation when the telephone transmitter is

given a sudden jar, or its circuit suddenly opened. In such cases discharges may take place in the tube, particularly in the higher power tubes and in parallel operation, which may be disastrous, as, for example, in the case of an arc from plate to filament. These surges may be regulated by means of safety gaps, electrolytic cells or aluminum lightning arrestors. Of these the safety gap is preferable, because of its low capacity properties; electrolytic cells are suitable for connection to the motor generator, if one is used, but should not be connected to the radio circuits. The best position for the safety gap is between grid and filament, as here it will circumvent discharge from plate to filament, thus preventing destruction of the filament. The width of the air gap will depend upon the type of tube used and will vary from  $\frac{1}{16}$  inch in the case of the 50-watt tube, to  $\frac{1}{4}$  inch for the 250-watt type. For lower powers (5 watts) the need for protection is not so great.

In circuits where an automatic grid bias voltage is obtained by means of a grid resistance and condenser, the bias vanishes when the tube stops oscillating and the mean plate current generally increases. This should be carefully watched, especially if the tube is being operated above its rated output, and the plate source disconnected at all times when there is no evidence of oscillation.

**46. Operation of Tubes in Parallel.**—Within reasonable limits the paralleling of tubes of the same type to secure greater output is feasible. Beyond a certain point, however, the plate resistance becomes too low and the use of a higher powered tube with larger plate resistance and amplification factor is desirable. In order to secure a good coöperation between paralleled tubes they should have as closely as

possible the same electrical characteristics. The uniformity of commercial tubes of the same type will generally be found adequate.

The first precaution to be observed in parallel operation concerns the size and design of the plate circuit apparatus and connecting wires. The ratio of transformation, that is, the size of the plate coil in the Meissner circuit, and the inductance between plate and filament taps in the other arrangements, will have to be decreased; and in this case the leads or connecting wires in the circuit should also be shortened so that their inductance does not constitute a larger percentage of the total inductance of this circuit. The cross-section of the conductors, including the plate coil itself, should likewise be increased in proportion to the number of tubes in parallel. To still further reduce the length of the radio frequency part of the plate circuit, the by-pass condensers shunting the plate source should be located as close to the radio frequency apparatus as possible, and not placed, for example, at the terminals of feed-wires stretched across the room.

Sometimes a very high frequency oscillation takes place between the tubes, which does not contribute to the useful output and lowers the efficiency, and oftentimes the output, of the set. This tendency may be checked by means of small choke-coils (20 turns No. 28 wire,  $1\frac{1}{2}$  inches diameter) inserted in the grid leads, close to the grid, as shown in Fig. 80 (c).

**47. Adjustment of the Transmitter.**—The adjustment, or “tuning-up,” of the transmitter has two objects: (a) securing maximum power output from the tube, or maximum antenna current at a given wavelength (preferably the fun-

damental); and (b) obtaining highest efficiency from the oscillator, that is to say, the highest ratio of power in the antenna to power supplied to the plate circuit. Both results can seldom be obtained at the same time, or with the same adjustment. The amateur will generally want to adjust

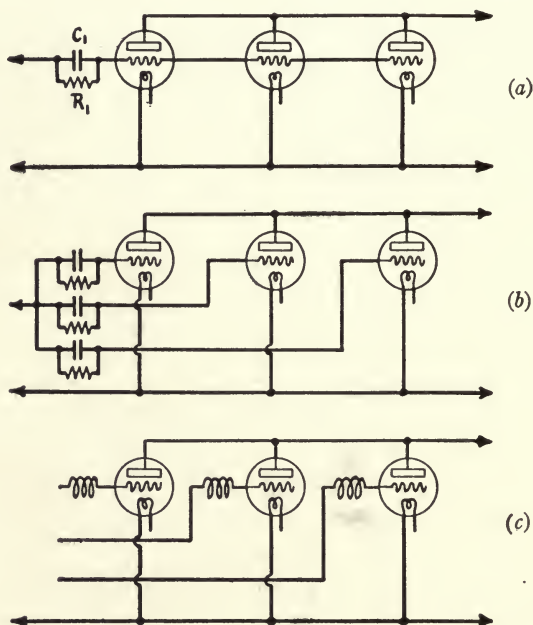

Fig. 80.—Relating to the operation of power tubes in parallel: (a) with common grid condenser and resistance; (b) with individual grid resistances and condensers; (c) showing insertion of small choke-coils to prevent ultra-radio-frequency oscillation between tubes.

for maximum output regardless of what the efficiency may be with this adjustment, so the manipulation or tuning-up will be discussed here from this point of view.

Since the aim is maximum antenna current, an antenna ammeter should be provided to gauge the current, or in

default of this some form of *low resistance, sensitive* resonance indicator may be used, such as a low c.p. automobile lamp which has been shunted with a copper strip or wire of proper length for the power used. In addition, it is decidedly convenient to have a plate circuit ammeter, so that at least some idea of the variation of the efficiency may be had.

The adjustment of the self-excited system under consideration comprises three principle operations as follows:

- (a) Adjustment of the inductance and capacity of the circuit for the desired wavelength;
- (b) adjustment of the ratio of transformation, or the coupling between the plate circuit and the antenna for maximum output into the antenna resistance at this wavelength;
- (c) adjustment to secure proper exciting voltage, or feed-back to the grid circuit.

Before commencing these adjustments reduce the plate voltage somewhat, so that the tube will not overheat while experimenting. Carefully check all connections before closing the power switches. If a modulating tube for telephony, or apparatus for c.w. or i.c.w. signalling is provided, see that this is disconnected from the oscillator or otherwise properly disposed. In case the circuit refuses to oscillate after the power has been applied, first try reversing the connections to the grid; then make the coupling between the grid and plate and load circuits as close as possible in those circuits where inductive coupling is used. The starting of the oscillation is generally indicated by a movement of the plate circuit ammeter.

The adjustment for wavelength is first made using a

wavemeter or by listening-in on a local calibrated receiving apparatus. It will be observed that the three adjustments are not independent, and a constant readjustment of the wavelength will be necessary in the course of the other adjustments, particularly in the less flexible circuits. A maximum of independence is attained in the Meissner arrangement. In adjusting for maximum power output be careful that this is not attained at the expense of a heavy plate current. Remember also that maximum power does not mean maximum current in the antenna *at any wavelength*, but at any particular wavelength, and if operation at the fundamental is essayed the output current may be very small, probably one-fifth of that which could be obtained by moving to a higher wavelength. Do not be deceived by a large antenna current, and in any case do not go about boasting of a 2 ampere antenna current with a 5-watt tube, for this species of self-delusion will never increase your signalling range, and is besides a pernicious doctrine to spread. Decide upon the wavelength, keeping as close to the fundamental as possible (if the fundamental is too low, build a larger antenna), and manipulate the clips or couplings until the largest antenna current is secured *at that wavelength*. The grid input will not usually be critical and can be adjusted last.

**48. Master-oscillator Systems.**—In this system the power tube acts as an amplifier of the power supplied by the small auxiliary exciting, or master, oscillator. The exciter must develop sufficient power to supply the losses in its own oscillating circuit and those of the grid circuit of the power tube. It is difficult to predict exactly what the upper limit of the losses in any power tube will be, for the grid current is



modified by the load in the plate circuit; an allowance of from 2 to 10 per cent. will, however, cover most cases. Because the plate circuit of the tube reacts upon the grid circuit and changes its effective capacity and resistance, it is advisable in order to minimize the effect of this upon the frequency of the oscillations generated by the exciter, to employ here some form of oscillating circuit in which a large capacity is employed. The Hartley circuit is well adapted for this purpose and is applied in Circuit No. 7. Then the adjustments for maximum transfer of power from the plate circuit of the power tube to the antenna can be made with a minimum of embarrassment from frequency changes.

A suitable master oscillator arrangement is illustrated as Transmitting Circuit No. 7, and the description of the apparatus is given in the accompanying table. The circuit is obviously suitable for direct ground or counterpoise. When operating above 350 meters, a frequency trap  $L'C'$  tuned to a wavelength equal to half the wavelength of the master oscillator, should be inserted in the antenna circuit to suppress the second harmonic of half wavelength which is emitted and may be disturbing to other stations on this wavelength. In this circuit the ratio of inductance to capacity should be small.

The adjustment of the master-oscillator system is extremely simple and easy, for the three adjustments (*a*), (*b*) and (*c*) mentioned in Art. 47 are almost independent. The antenna circuit is first tuned to the proper wavelength; then the frequency of the exciter is adjusted by varying either the taps on the coils  $L_1$  or  $L_2$ , or the capacity at  $C$  (this may be shunted by a variable condenser for greater convenience) until the antenna current is a maximum. The

exciting voltage for the grid of the power tube is obtained by inductive coupling with  $L_2$  or by tapping in on this coil as shown in the diagram. Setting this tap roughly at its best value, adjust the inductance  $L_p$ , capacity  $C_p$ , and coupling between the plate coil and antenna for maximum antenna current. Then return to the grid circuit and re-adjust the tap  $S$ , and grid resistance and condenser ( $R_1C_1$ ) for best excitation. The last adjustments are not wholly independent; also some readjustment of the wavelength of the oscillator may have to be made during these manipulations. But the experimenter will find a great deal of pleasure in working with this circuit, particularly after experience with the self-excited systems. It is in all respects a clean-cut and convenient arrangement.

#### 49. Modulation Methods for C.W. and I.C.W. Telegraphy.

—While this book is devoted ostensibly to the radio telephone, yet the methods and circuits are so closely allied to those used in the continuous wave (c.w.) and interrupted continuous wave (i.c.w.) methods of telegraphy that it seems worth while to include a description of the small modifications necessary for this type of signalling.

In c.w. work the continuous radio frequency output of the set is broken up into dots and dashes by means of a telegraph key. These signals are detected at the receiving station by the heterodyne method, to be described in Chapter VI. The i.c.w. method differs from this in that the output is further broken up into small lumps at a rate chosen to give a pleasing musical note to the signal when received by the ordinary detection method. The communication range in miles per watt radiated with the first type of signalling is enormous compared with the range for

the older "spark" transmitters. But this does not apply to the second method, and except for its selectivity advantages, it is decidedly inferior to the "spark" method. This contradicts some prevalent notions and dicta, but is nevertheless supported mathematically and by the experimental results.\*

For c.w. and i.c.w. working, the key is usually and preferably situated in the grid circuit, except when a special stability of frequency is desired. The exact connections are indicated in Fig. 81.

The arrangement (a) is simpler, but the throttling action with tubes having a low grid circuit resistance may be too

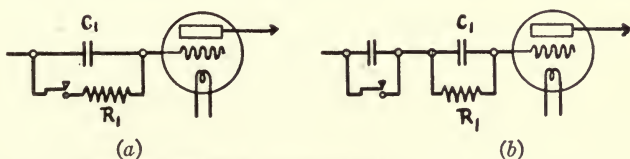

Fig. 81.—Showing connection of telegraph key to oscillator for c.w. signalling: (a) arrangement for low power, (b) arrangement necessary with higher power to prevent voltage surges in the circuits.

rapid and dangerous transients may result. The arrangement (b), in which the key short circuits a condenser large enough to give, with the grid circuit resistance and  $R_1C_1$ , a sufficient time constant, is preferable in such circumstances. This latter arrangement is especially indicated for paralleled tubes where the effective grid resistance may be quite low. A capacity of from  $\frac{1}{10}$  to 2 mfd. will be necessary, depending upon the tubes employed.

\* In making this statement, ordinary detection (with or without regeneration, but retaining the note of the signal) is contemplated. This type of signal may also be heterodyned, and the range considerably increased thereby, but the note is lost and it is no longer an i.c.w. signal.

Sometimes the key is inserted directly in the antenna circuit. This may be successful in the case of low powers, but is bad practice and overheats the tubes. The modulation may also be accomplished by producing a small change of wavelength. For this system, two or more turns of the antenna coil  $L_0$  or a small coil coupled to it, may be short-circuited by the key. In the master-oscillator system, Circuit No. 7, this loop may be coupled to  $L_1$  or  $L_2$ , or one or two of their turns shorted.

For i.c.w. work, in addition to the signalling key, some means for interrupting or completely modulating the antenna current at an audible frequency is required. A motor-

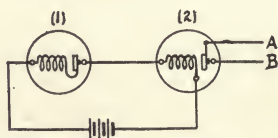

Fig. 82.—Two-buzzer scheme for use as modulator of output current for i.c.w. telegraphy.

driven interrupter or “chopper” will be useful where large currents are to be interrupted and a generous contact surface should be available. For small currents, the double buzzer scheme shown in Fig. 82 is frequently useful. The purpose of the first buzzer (1) is to cause the armature of buzzer (2) to vibrate, thus interrupting its contacts at the desired rate.

These contacts ( $A$  and  $B$ ) may be inserted in the antenna circuit, or across one or two turns of the antenna coil  $L_0$ , or in the case of a radio telephone installation already provided with a modulator tube, may take the place of the speech operated microphone. In the last connection it is

advisable to shunt the contacts with a variable resistance to be adjusted until the proper modulation is obtained.

**50. Methods of Modulation in Radio Telephony.**—As we have previously pointed out, the function of the modulating device in the radio telephone transmitter is to vary the output current of the r.f. generator in accordance with the low frequency variations of the sounds to be transmitted. Many schemes have been devised for the control of the output current, operating principally by three fundamental methods as follows:

- (a) Variable absorption in the load circuit (antenna);
- (b) variation of the grid voltage of the generator tube either directly or by modulation of a master oscillator;
- (c) variation of the plate voltage, or power supplied to the plate circuit of the oscillator tube.

Omitting any hybrid schemes, of small technical importance, we shall indulge in a critical discussion of these methods and describe circuits for their application. It is not necessary to remark that the spirit of this discussion will be utilitarian rather than technical, and will be utilitarian in the special sense of economy of apparatus and tubes. For a very excellent technical discussion of these matters the reader is referred to Mr. E. S. Purington's paper on the "*Operation of the Modulator Tube in Radio Telephone Sets*," published as Scientific Paper of the Bureau of Standards, No. 423 (copies obtainable from Supt. of Documents, Govt. Printing Office, Washington, D. C., for 10 cents).

**51. Modulation by Power Absorption.**—The first of these methods is mainly of historical importance and at least for high powers (over 5 watts) is rapidly becoming obsolete.

An example of it is furnished by the classical picture of a speech operated microphone inserted in series with the antenna, or included in a circuit inductively or directly coupled thereto. For best results the effective "talking resistance" of the microphone should be equal to the antenna resistance; and by *effective* talking resistance I mean the actual resistance when the device is directly in the antenna circuit, and the referred resistance (equal to the actual resistance divided by the ratio of transformation, unity coupling) when it is coupled to it. The purpose of coupling is in fact to reduce the effective resistance of the average high-resistance microphone so that the above simple relation is satisfied.

This method is inherently a poor one, not only from the viewpoint of distortion, but from that of efficiency as well. For the amateur its attractiveness lies in its economy, and for low powers (5 watts or so) fair results can be secured by its use, in spite of many technical objections. In applying the garden variety of microphone (borrowed perhaps from some idle wire 'phone), connect it across a few turns of the antenna coil and then increase the number of turns until there is evidence of its overheating or the quality and intensity of the speech as reported by a distant receiving station, ceases to improve. Just how far the increase of the number of turns can be carried out, and the effectiveness of the microphone thereby improved will depend upon the power to be modulated. Figure 83 shows the connections contemplated. Modifications of this idea are frequently employed in which by amplifying the effect of the microphone, higher powers can be successfully modulated. Examples of such systems are furnished by a speech operated audion amplifier, and by the magnetic modulator developed by the

Radio Corporation of America. The latter device is of considerable interest to amateurs because it has been put into a thoroughly practical form, especially designed for short wave work, and is available on the market.

**52. Modulation by Grid Voltage Variation.**—The second method of modulation depends upon a variation of the average (biasing) grid voltage of the oscillator tube in a self-excited system, or its equivalent, the modulation of the output current of the exciter in the separately-excited system. Like the previous method (modulation by absorption), this system flourishes mainly on account of its economy of apparatus, for its principle is fundamentally

a poor one. In the self-excited oscillator this follows from the experimental fact that the relation between the grid biasing voltage and the antenna current is not even approximately linear, as it obviously should be for good modulation. In fact, the output current is but slightly affected

by changes in the grid biasing voltage throughout a substantial range in which the oscillations are stable; and if the grid voltage is reduced below this range the oscillations cease altogether and the antenna current falls to zero. The reader will easily see that such characteristics are unfavorable for faithful reproduction of the speech vibrations. The situation is, however, not hopeless and by careful adjustment of the circuit and modulating voltage limits a tolerably satisfactory operation is possible.

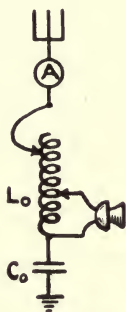

*Fig. 83.—Showing connection of microphone to antenna coil for modulating output current in radio telephony (absorption method).*

A suitable circuit for grid modulation is shown in Fig. 84. The parts and apparatus not essential to the modulation have been omitted. The secondary of the modulation transformer  $T$  takes the place of the grid resistance  $R_1$ , either when it bridges the grid condenser as at (a), or is connected between the grid and filament as at (b). In the latter case it is necessary to insert the 3 m.h. radio frequency choke-coil  $X$  in series with the secondary to prevent it from short-circuiting the grid circuit for the radio frequencies. The design of the transformer will depend upon the electrical

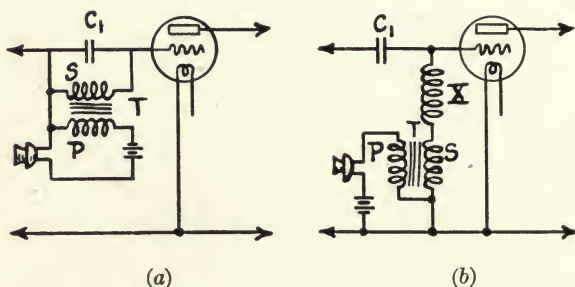

Fig. 84.—Circuit for modulation by variation of the grid voltage of the oscillator tube.

characteristics of the tube, but since this system is not suitable for higher powers than 5 watts, or possibly two or three 5-watt tubes in parallel, the transformer described in Art. 53 for the Heising modulation and the 5-watt tubes, can be recommended here. Before taking the trouble to build a special transformer, however, the reader should try an ordinary "spark coil." Those of the "Ford" variety have been successfully employed by many amateurs.

**53. Modulation by Plate Voltage Variation.**—The third method of modulation, by variation of plate voltage, plate



current, or plate power, excels by reason of the experimental fact that a substantial proportionality exists between the output current and the plate voltage over a wide range, and also because there is no waste of the oscillator's power, as in the absorption method. In the practical application of this principle a voice voltage is superposed upon the d.c. voltage in the plate circuit, causing the plate current and thus the plate power to fluctuate at speech frequencies. A complete fluctuation from zero current to double current entails an amount of power approximately equal to that supplied to the unvaried oscillator, hence the modulating device must be capable of either furnishing this power or controlling its supply from the plate source. For this reason, the microphone in itself, although acting as an amplifier in its normal connection, is yet incapable of controlling the power supplied by tubes of 5-watt and high ratings and its effect must be amplified by means of another audion. This auxiliary tube is for obvious reasons designated as the *modulator tube*.

In this rôle the modulator tube may be regarded in two ways: as a speech controlled amplifier or generator of speech-frequency power (the microphone and its battery serving as an exciter), or as a speech operated resistance, which, inserted in series with the plate source and the oscillator tube causes the voltage of the latter to vary. These points of view are equivalent, although explanations may be found in the literature of the subject which make a rather sharp distinction between them. Reference is made to the classification of "constant voltage" and "constant current" systems illustrated in Fig. 85.

The constant voltage scheme is shown at (a). Here the oscillator tube is represented by the resistance  $R_2$ , and the

modulator tube (regarded as a speech controlled resistance) is represented as  $R_1$ .  $E_b$  is the constant plate voltage. There are many ways of viewing the action, having the common result that the voltage across  $R_2$  undergoes variation with the variation of  $R_1$ . At (b), instead of the constant voltage a constant current ( $I_b$ ) is available, and variations of  $R_1$  will in this case also cause a variation of the voltage across  $R_2$ . In the practical application the constant current action in the common branch is secured by inserting a large choke-coil in series with the d.c. plate source. For maximum effectiveness the simple relation

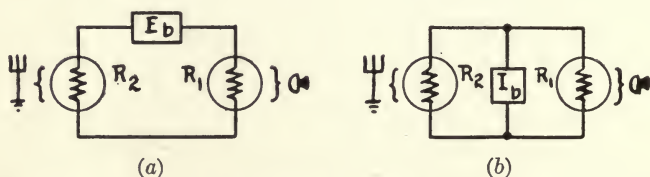

Fig. 85.—Illustrating schematically the so-called constant voltage (a) and constant current (b) systems of modulation by variation of plate power.

stated for the absorption system that  $R_1 = R_2$ , must be satisfied, which accounts mainly for the familiar prescription that the modulator and oscillator tubes shall be electrically identical. Thus if the oscillator consists of a bank of ten 5-watt tubes, the modulator should comprise a similar bank of tubes.

Now adopting the other viewpoint, the modulator may be thought of as a generator (excited by the microphone and battery in its grid circuit) of speech-frequency power. This power is to be supplied to the oscillator tube in place of the steady power used when telephonic communication is not undertaken. The oscillator tube acts therefore as the load

(approximately a resistance), Fig. 86, and, as is well known, the maximum amount of power will be transferred to it when its resistance is equal to that of the generator tube. This is the conclusion already arrived at. The choke-coil  $X$ , serves to prevent the short-circuiting of the output circuit by the plate source in the same way that the 3 m.h. choke-coil prevented this in the previous radio diagrams.

The reader will have his own preference of either the first or second methods of viewing the modulator action. The

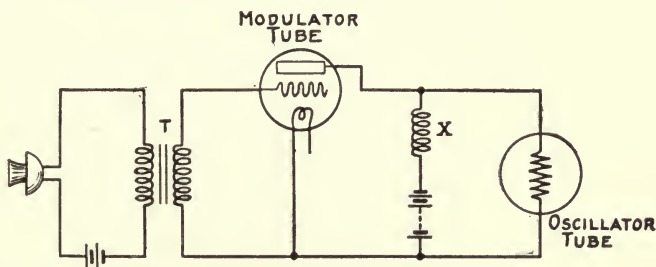

Fig. 86.—Schematic diagram of the Heising system of modulation, in which the modulator tube is depicted as a speech excited generator supplying speech-frequency power to the oscillator tube.

latter is perhaps more harmonious with the other explanations of the audion's action as a generator given elsewhere in this book. Previously we discussed the generation of r.f. currents; here the currents are of speech frequencies.

A practical system applying this method of modulation was first described by Mr. R. A. Heising of the Western Electric Co., a fact which accounts for its being referred to as the "Heising system" of modulation.

The operation of this system of modulation is nicely illustrated in Fig. 87. This is a photograph\* of the speech-

\* For this very clear and interesting oscillogram I am indebted to Mr. E. S. Purington, of the Hammond Radio Research Laboratory, Harvard University.

frequency current variations which took place in a circuit of the type, Fig. 86, when the word "Johnson" was spoken into the microphone. The upper trace, labeled "Modulated Load Current," represents the plate current of the oscillator tube and the r.f. output current will be moulded in this form; in the middle curve, "Modulator Current," the plate current of the modulator tube is shown; and the lower trace represents the current in the common or choke-coil branch, which remains practically constant.

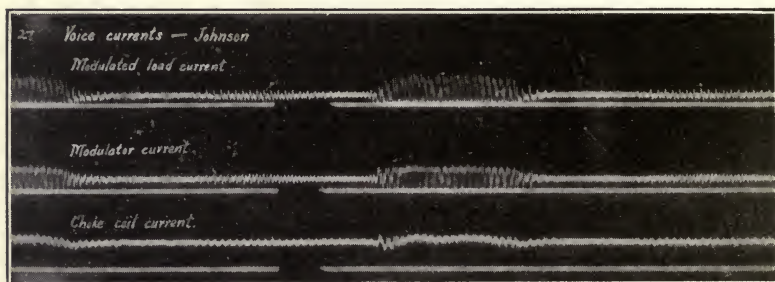
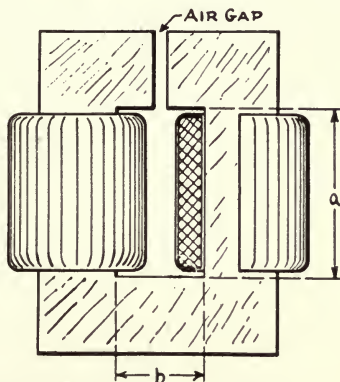

Fig. 87.—Photograph showing the operation of the Heising system of modulation. Currents flowing in circuit of Fig. 86 when the word "Johnson" was spoken into the microphone (Purington).

An ideal choke-coil would have an infinite impedance throughout the entire range of important speech-frequencies from 100 to 5000 cycles; but since it is impossible to build coils without resistance, the practical attainment of an extremely high impedance is checked by the increasing heat loss in the coil, due to the passage of the normal plate current for the two tubes through it. Moreover, the gain in power transfer from modulator to oscillator is not proportional to the impedance of this coil, but falls off as it is increased. A small calculation shows that a transfer of

6 HENRY CHOKE-COIL FOR HEISING SYSTEM OF MODULATION



Arrangement of windings and core, showing air-gap for reducing normal flux-density.

SPECIFICATIONS

Power Rating of Tubes (Watts).	5 w.	50 w.	250 w.
Average direct current.....	0.1 a.	0.3 a.	0.6 a.
Conductor (B. & S.).....	No. 28	No. 24	No. 22
No. turns (total).....	3000	3000	3000
Amount wire required.....	$\frac{3}{4}$ lb.	$3\frac{1}{2}$ lbs.	$5\frac{1}{2}$ lbs.
Core dimensions.....	$2'' \times 1''$	$3\frac{1}{2}'' \times 1\frac{1}{2}''$	$4'' \times 2''$
Core cross-section.....	$\frac{7}{8}'' \times \frac{7}{8}''$	$1\frac{1}{2}'' \times 1\frac{1}{2}''$	$2'' \times 2''$
Width of air gap.....	$\frac{1}{32}''$	$\frac{3}{32}''$	$\frac{3}{8}''$
Resistance (d.c.).....	77 ohms	64 ohms	44 ohms
Heat loss (watts).....	.77	5.8	16

Core.—No. 26 B. & S. silicon-steel laminations.

Design Data.—Average permeability assumed = 3000; flux-density = 5000 lines/cm.<sup>2</sup> for magnetizing force = 1.75 c.g.s. units; conductor allowance = 1000 circular mils/ampere.

Fig. 88.—Data for the construction of 6-henry choke-coil for modulation by the Heising method, using storage battery or motor-generator source of plate supply.

about 80 per cent. of the power (90 per cent. of the current) will be obtained when the choke-coil impedance is equal to twice the resistance of the modulator and oscillator tubes in parallel. These tubes are to be of the same type so that their resistances will be equal and the above statement will mean that this transfer is secured when the impedance is equal to the resistance of either tube. The impedance of the available tubes described in Art. 41 averages about 4000 ohms, hence at the lower limit frequency of 100 cycles, an inductance of 6 henries is indicated. Since the coil carries normally the steady d.c. plate current of both tubes, it should be designed carefully so that the iron is not operated with too high a flux-density. An air gap in the iron circuit is the most economical solution of this problem. Specifications for a 6-henry choke-coil suitable for two 5, 50 and 250 watt tubes are given in Fig. 88.

The complete modulation circuit is shown in Fig. 89. The filament and plate sources are indicated symbolically as in the previous diagrams, and are usually common to both oscillator and modulator. The two wires pointing to the left are connected to the oscillator tube (in both the self-excited and master-oscillator systems) in place of the "B" battery or plate source in the other diagrams.

The modulation transformer  $T$  should supply, with average intensity of speech, a secondary voltage sufficient to completely modulate the oscillator's output. This will usually be accomplished if the range of modulator plate current is from zero to twice its normal value. The proper variation of grid voltage to produce this change in plate current depends, of course, upon the tube to be employed. It will not generally be possible to produce this grid variation

in the case of high power tubes because their grid losses and the dielectric losses in the secondary of the modulation transformer will exceed the small amount of power available in the microphone circuit. The 50-watt tube is regarded as the limit of direct control. A description of a modulation transformer suitable for the 5-watt tubes, UV-202 Radiotron, and Western Electric "E" tube, is contained in Fig. 90.

The grid is kept at a suitable negative potential by means of the biasing battery "C" which also supplies current for the microphone circuit. Regarding the correct biasing voltage, nothing definite may be said. Ordinarily

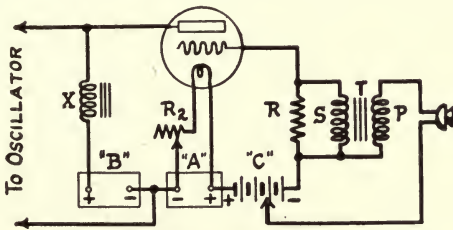
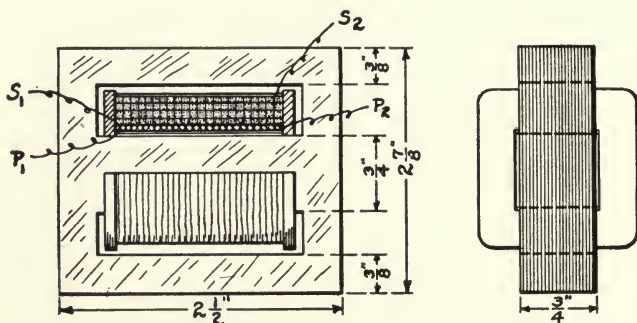

Fig. 89.—Showing actual connections of modulator tube for Heising modulation.

this would be adjusted so that the modulator plate current and the normal oscillator plate current (with the tube in the oscillating state) are about equal. This will be obtained with a bias of approximately  $-25$  volts in the case of the 5-watt tubes, and  $-60$  volts in that of the 50-watt type. However, a practice, instituted first I believe, by Mr. L. R. Damon of the Federal Institute of Radio Telegraphy, of using an abnormally large negative bias ( $-120$  volts for the 50-watt tube) has been reported to yield better results and speech of superior quality. This is hard to account for theoretically, and is one of the cases where theory must bow before practice, for these results have been repeatedly

### MODULATION TRANSFORMER FOR 5-WATT TUBES

(RADIOTRON, UV-202; W. E. CO. "E" OR VT-2)



#### WINDING SPECIFICATIONS

	Primary.	Secondary.
No. turns.....	220	22,000
Conductor.....	No. 24 B. & S.	No. 40 B. & S.
No. feet required.....	78	9000
No. ounces.....	2 oz.	5 oz.
Resistance.....	2 ohms	9505 ohms

*Core.*—No. 30 B. & S. gauge silicon-steel.

*Notes.*—Design based upon standard Western Electric microphone with 12 volt battery; average secondary voltage (resistance load =  $\frac{1}{4}$  megohm) for average talk = 30 v. r.m.s.

Fig. 90.—Constructional details of modulation transformer for 5-watt tubes (see Fig. 89).

verified by a number of experimenters.\* It is therefore un-

\* Those who have listened to the broadcasting from Mr. Damon's station "WRP" (Camden, N. J.) will be able to judge the efficacy of this system of biasing. The quality of speech, especially the sounds "s," "f," "th," etc., in the upper range, is unusually good.



hesitatingly recommended for trial where "C" battery facilities of this size are available. Mr. Damon increases the bias voltage until the antenna current ceases to increase when the microphone is spoken into.

The resistance  $R$ , of value 1 or 2 megohms (megohm = one million ohms), controls to some extent the secondary voltage when there is no grid current and thus reduces distortion. It also checks the tendency, manifested particularly with the Western Electric "E" tube, toward "blocking," that is, sticking at a positive grid voltage.

## CHAPTER V

### SOURCES OF POWER

**54. Enumeration of the Methods of Power Supply for the Plate Circuit of the Transmitting Tube.**—As the reader will know, or have gleaned from the description of the power tubes in Art. 41, the audion requires for its operation in radio telephony d.c. plate voltages ranging from 350 to 2000 volts, with which the corresponding plate currents (per tube) range from 0.040 to 0.250 ampere; and filament lighting currents of from 2 to 15 amperes. In radio telephone work the power supply, at least for the plate circuit, must be substantially steady, otherwise its fluctuations are heard by the receiver and produce a decidedly disagreeable type of interference with the speech or other sounds generated by the legitimate variation of the plate voltage by the modulator. For c.w. work (see Art. 49), in so far as the actual heterodyne reception is concerned, it is not important that the plate supply should be steady; in fact, I shall describe circuits later in which an alternating voltage is applied directly to the plate, but in this case the signal will be audible in the ordinary receiver and the operator should be very careful about causing interference. This practice, in which a.c. is applied directly to the plate, is excusable only from the point of view of economy, and even this excuse is a meager one in view of the cheapness and ease with which a chemical rectifier and filter circuit may be constructed. The amateur

is urged to consider the rights of his fellows when contemplating an installation of this type for c.w. work, or in maintaining for telephone work a system of supply in which through defective filtering or for any other reason, a fluctuating plate voltage is obtained. For nothing more disagreeably assails the ear than the monotonous drone of a 60-cycle supply current. This is especially important in cities and in other places of radio station congestion.

The primary source of power is usually the 60-cycle a.c. lighting mains, although in some cases it may be possible through proper arrangements to secure d.c. at 500 to 600 volts from the feeders of a local street-railway system. But considering only the first supply, the methods of converting it into d.c. of the proper voltage may be divided into two general classes: (1) by means of a motor-generator set, and (2) by the use of a step-up transformer, rectifier and electrical filter. The first method is the more convenient, reliable and flexible, but its expense has prevented any extensive use in amateur stations. The transformer-rectifier-filter scheme appears to be the most accessible to amateur operators, and is very cheap and gives good results. The rectifiers are generally of the thermionic, chemical (electrolytic), or mechanical types, and used in conjunction with a proper electrical filter, their output voltage is reasonably steady and free from the undesirable "ripples." In the articles to follow the construction of suitable systems of this type will be taken up.

**55. Supply of Power for Heating the Filament.**—The life of a power tube is that of its filament, and a consideration of the proper operation of the filament is therefore of prime economic importance. This is especially true

with the higher power and more expensive tubes, and the amateur should constantly guard against a natural tendency to give little or no thought to this most vital part of his equipment, which burning brightly one moment, may be dark the next.

For lighting the filament a.c. should be given preference over a unidirectional current. This is fortunate, for the proper voltage and current can be easily derived from the 110 v. power mains by means of a small step-down transformer. The reason for this recommendation has already been stated (Art. 41, description of 250-watt Radiotron). Briefly, the use of a.c. prevents one-half of the filament from carrying more, and the other half less, than their shares of current, as would happen if the unidirectional thermionic plate current were superposed upon a unidirectional heating current. Like the classical chain, the filament is no stronger than its weakest link, and the whole filament may as well be overloaded as one-half of it in this manner, so far as the reduction of its life is concerned; hence the use of a.c. is to be recommended even in cases where it is not available and has to be specially generated for the purpose. The overloading of one side of the filament with a d.c. supply varies from 1 per cent. to 1.5 per cent. for normal operation, which involves, according to life tests made on the filaments of these tubes, a decreased longevity of from 15 to 20 per cent. The importance of a.c. operation depends therefore upon the cost of the tube; in the case of a 5-watt tube, the use of d.c. when a.c. is not obtainable may be justified.

The a.c. for the filament is usually obtained when an a.c. transformer is used for the plate supply, from an

FILAMENT TRANSFORMER

SUITABLE FOR SUPPLY OF TWO 5-, 50- AND 250-WATT TUBES

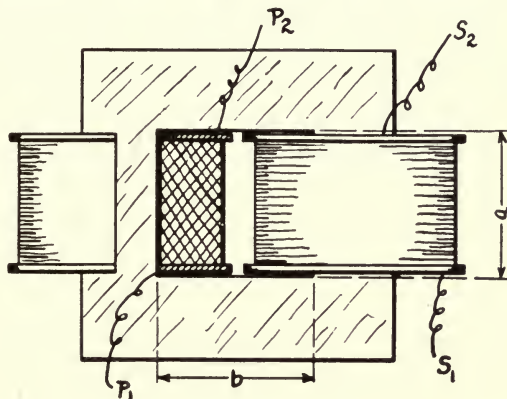

DETAILED SPECIFICATIONS

Power.	5 w.	50 w.	250 w.
Power rating.....	40 w.	200 w.	440 w.
Efficiency.....	75%	85%	85%
Primary voltage (60 cycles)...	110 v.	110 v.	110 v.
Secondary voltage.....	10 v.	13 v.	13 v.
Primary turns.....	500	500	250
Primary conductor (B. & S.)...	No. 22	No. 16	No. 12
Secondary turns.....	45	60	30
Secondary conductor (B. & S.).	No. 12	{6 No. 16 in parallel	{6 No. 12 in parallel
Amount of wire required.....	{P. 1¼ lbs. S. 1 lb.}	6 lbs.	7 lbs.
Core dimensions (a x b).....	2½" x 1½"	3" x 3"	3" x 3"
Core cross-section.....	1" x 1"	1½" x 1½"	2" x 2"

Core Laminations: No. 26 silicon-steel.

Fig. 91.—Data for the construction of filament lighting transformers suitable for two 5-, 50- and 250-watt tubes.

auxiliary winding upon this transformer. When a motor-generator or storage battery is used for the plate supply

a separate filament transformer will be required. Specifications and full constructional details of suitable transformers for two 5-, 50- and 250-watt tubes are given in Fig. 91.

A tap should be brought out from the center of the secondary winding and it is to this that all connections from the grid and plate circuits should be made (see Transmitting Circuit No. 1, Art. 42). This is done so as not to introduce into these circuits the voltage fluctuations due to the drop in the filament which would be included by connecting to one end of the filament. It will not be necessary to provide a by-pass condenser for this winding because if the tap is at the exact center of the winding there will be no effective inductance between it and the ends of the coil.

The life of the filament depends upon the temperature at which it is operated, and this temperature will be roughly proportional to the rate at which heat ( $= I^2 R$ ) is developed by the electric current. While the filament is burning, its material is constantly evaporating, or being thrown off and deposited upon the electrodes and the walls of the glass container. The dark appearance of old audions and electric light bulbs is a familiar manifestation of this action. As the amount of material diminishes, the resistance of the filament, of course, increases, with the result that if it is operated with a constant filament current the operating temperature goes up continually as the tube gets older. The abridgment of its life is the result of such practice. Few amateur stations are, however, equipped with a radiation pyrometer with which to measure the filament temperature, so it is rather hard to keep the temperature con-

stant during the life of the tube. A practical scheme, suggested by the manufacturers of the tubes, to restrain the operation at increasing temperature is to use, rather than constant current, a constant voltage; the temperature is roughly proportional to  $E^2/R$  (*voltage squared ÷ resistance*) and as the resistance goes up due to evaporation, the operating temperature decreases, and the life of the tube is prolonged on two counts. The makers of the tubes also state that an increase of 3 per cent. of the rated current halves the life of the tube, and a decrease of 3 per cent. doubles it. This will indicate the extreme importance of proper attention to this detail of operation.

**56. Self-rectifying Circuits.**—The so-called self-rectifying circuits utilize an a.c. plate supply, the appropriateness of the terminology being due to the action of the audion oscillator in permitting the passage of current only during the positive half of the cycle. If a sinusoidal a.c. is applied directly to the plate, the current in the plate circuit, likewise the output current, will undergo such variation and the signals will be audible in an ordinary receiver. Telephony is rather difficult with this type of supply; but for c.w. work its use is perfectly feasible and distances almost as large as those obtainable with the same amount of d.c. power may be covered. The heterodyne note is somewhat peculiar and invested with a 60- or 120-cycle hum, but is not at all unpleasant. The unpleasant part falls to the lot of the nearby receiving station.

The self-rectifying systems may be divided into two classes: those utilizing with one tube but one-half of the a.c. cycle; and those employing a symmetrical arrangement of two tubes for utilizing both halves of the cycle.

The latter system may be improved by the addition of a large choke-coil, which somewhat reduces the current fluctuation. The canonical form of electrical filter does not seem to be applicable to this system.

A circuit using one tube and but one-half of the a.c. cycle is shown in Fig. 92. Here the wires *P*, *G* and *F* connect to the oscillating circuit, suitable forms of which have been indicated. *X* is a radio frequency choke-coil. The application of this scheme to the circuits shown in Art. 42 will occur to the reader. If the plate source is in series with the radio frequency part of the plate circuit, it will

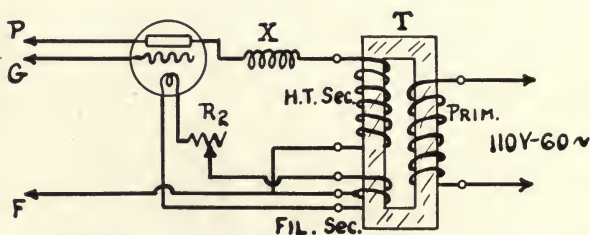

Fig. 92.—Self-rectifying circuit using one-half of the a.c. cycle.

usually be necessary to shunt the secondary winding with a by-pass condenser of at least 0.002 mfd. capacity. A center tap on the filament winding is not necessary.

In the symmetrical arrangement with two tubes shown in Fig. 93, both halves of the cycle are used, one tube operating during the positive alternation and the other during the negative alternation. In this case the secondary of the transformer is provided with a center-tap to which the common terminal of the filament is connected. The iron-core choke-coil  $X_2$  is inserted in the common lead to smooth out the ripple, for which purpose its inductance



should be as high as possible, 10 to 50 or even 100 henries, and its design preferably embodies an air gap, as in the case of the 6-henry choke-coil described in Fig. 88. The condensers  $C$  (capacity at least .002 mfd.) serve to isolate the oscillating circuit from the high voltage source, and enable the plates to be connected (from a radio frequency viewpoint) in parallel without short-circuiting this source. The wires  $P$ ,  $G$  and  $F$  connect to a suitable oscillating cir-

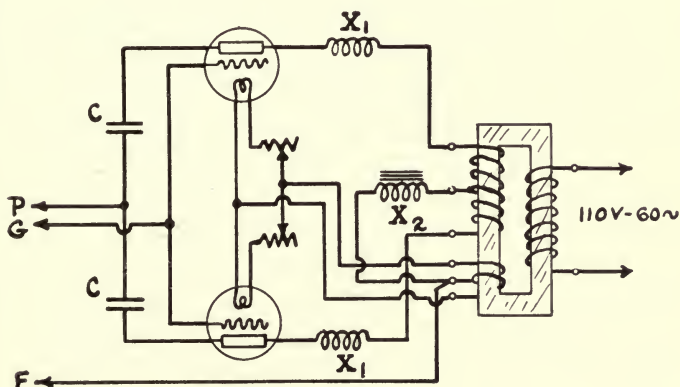

Fig. 93.—Self-rectifying circuit using both halves of a.c. cycle with symmetrical arrangement of tubes, and choke-coil to reduce current fluctuation.

cuit. Other arrangements are possible; for example, those in which the so-called *symmetrical oscillating circuits* are employed. These are, however, uneconomical of apparatus and in general harder to operate, and having no compensating advantages for amateur use will not be described.

**57. System of Plate Supply Employing Step-up Transformer, Rectifier and Electrical Filter.**—This scheme for securing an approximately steady voltage for the plate circuit of the power tube is illustrated symbolically in

Fig. 94. The method shown at (a) employs but one rectifier and uses, of course, but one-half of the a.c. cycle; the method (b) uses a symmetrical arrangement of two rectifiers  $D_1$  and  $D_2$ , and operates on both halves of the cycle. This is vastly superior to the first scheme and will therefore form the nucleus of this discussion.

The system embraces three essential parts: a step-up transformer, through which power at the proper voltage is derived from the 110 volt a.c. line; a set of rectifiers  $D_1$  and  $D_2$ ; and an electrical filter. The audions are represented symbolically as a resistance load. The purpose

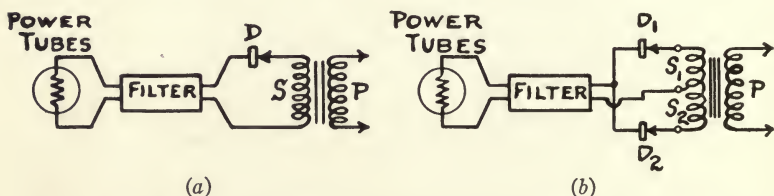

Fig. 94.—Schematic diagram of systems of plate supply using a.c. step-up transformer, rectifier and electrical filter: (a) using one-half of the a.c. cycle; (b) using both halves.

of the filter is to suppress variations of the current supplied to the load, or as commonly expressed, to “smooth out the ripples.” This may take a variety of forms, from a simple choke-coil to the more elaborate Campbell arrangement with recurrent similar sections. The rectifiers  $D_1$  and  $D_2$  are usually of three types: thermionic, chemical and mechanical. Of these the thermionic and chemical types are the most satisfactory; the latter being especially economical of power and easy to construct and to operate. In the following articles the design, construction and operation of the three elements will be given detailed consideration.

58. **Elementary Theoretical Basis for the Design of the Transformer-rectifier-filter System.**—This note is inserted for the reader who may be interested in the theoretical side of the design and operation of the system under discussion and who will want to know upon what basis the constructional data given in the following articles rests; the average reader may skip this and go on with the next article. The design here undertaken proceeds on a quasi-scientific basis as follows:

The rectifier is assumed to be perfect, that is to say, completely obstructs the passage of current during the

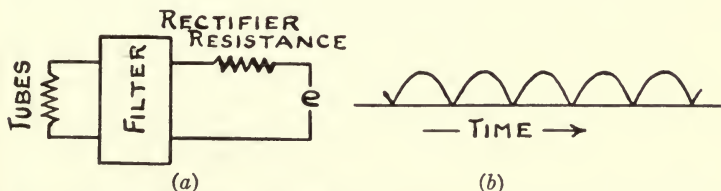

Fig. 95.—Equivalent electrical circuit for system of Fig. 94 (b), and (b) form of e.m.f. acting therein.

negative half-cycle, and permits its passage in proportion to the voltage applied, during the positive half-cycle. This condition is practically fulfilled in the case of the chemical and mechanical types, if the capacity effect of the film in the chemical type is small. In these circumstances, and provided also the transformer is closely coupled, the system may be replaced electrically by the simple circuit of Fig. 95 (a) in which an e.m.f., “ $e$ ,” of the form shown at the right (b) acts. This e.m.f. is compounded of a number of alternating constituents, of frequencies 0, 120, 240, 360, 480, etc., cycles per second, and with amplitudes represented graphically in Fig. 96. The first constituent (zero fre-

quency, direct current) is all that we desire to flow in the output circuit; the others represent fluctuations in the supply current and are to be suppressed by the filter.

The amplitude of the d.c. component is  $2/\pi$  ( $=.636$ ) of the maximum value of the a.c. voltage wave, or with a sine wave, .9 times the r.m.s. value of the wave. This is the clue to the transformer design; the suppression of

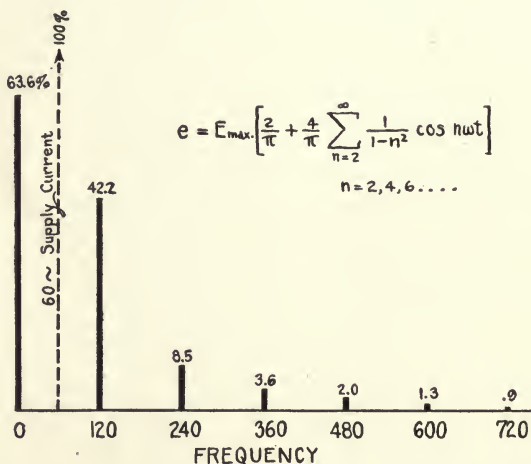

Fig. 96.—Illustrating relative magnitudes of d.c. component (zero frequency) and harmonics in the voltage wave of (b) Fig. 95.

the higher frequencies will be considered in the article on filters. Note that the d.c. in the transformer secondary flows in opposite directions from the center-tap to the two ends of the coil and produces no steady magnetization, and that half of the secondary winding works during one-half-cycle, the other during the other half-cycle. Thus each coil works, so to speak, on half time and the heating

TABLE II

SPECIFICATIONS FOR THREE TRANSFORMERS CAPABLE OF SUPPLYING POWER FOR FOUR 5-WATT, TWO 50-WATT AND TWO 250-WATT TUBES RESPECTIVELY

Rating of Power Tubes.	5 w.	50 w.	250 w.
Power rating . . . . .	250 w.	700 w.	2200 w.
Normal primary voltage . . . . .	110 v.	110 v.	220 v.
Primary current (full load) . . . . .	2.5 a.	6.5 a.	10.8 a.
Efficiency . . . . .	90%	90%	90%
Primary turns, for 102 volts . . . . .	306	204	204
“ “ “ 105 “ . . . . .	315	210	210
“ “ “ 108 “ . . . . .	324	216	216
“ “ “ 110 “ . . . . .	330	220	220
“ “ “ 112 “ . . . . .	336	224	224
“ “ “ 115 “ . . . . .	345	230	230
Primary conductor (B. & S.) . . . . .	No. 14	No. 12	No. 10
Amount of wire required . . . . .	4½ lbs.	3½ lbs.	7 lbs.
Filament secondary voltage . . . . .	8 v.	10 v.	11 v.
Filament current . . . . .	10 amp.	13 amp.	30 amp.
Filament secondary turns . . . . .	24	20	11
“ “ “ conductor . . . . .	{ 3 No. 14 in parallel	{ 3 No. 12 in parallel	Note 2
H.T. secondary voltage, E <sub>1</sub> . . . . .	400 v.	1200 v.	2200 v.
“ “ “ E <sub>2</sub> . . . . .	500 v.	1500 v.	2600 v.
“ “ “ E <sub>3</sub> . . . . .	700 v.	1700 v.	3000 v.
H.T. secondary turns; Tap No. 1..	450	400	400
“ “ “ “ No. 2..	900	1000	800
“ “ (Center tap); No. 3..	2100	3400	3000
“ “ turns; Tap No. 4..	3300	5800	5200
“ “ “ “ No. 5..	3750	6400	5600
“ “ “ “ No. 6..	4200	6800	6000
H.T. sec. conductor (B. & S.) . . . . .	No. 28	No. 28	No. 24
Amount of wire required . . . . .	2 lbs.	3¼ lbs.	9 lbs.
Core dimensions (a x b) . . . . .	4" x 2½"	4" x 3"	5½" x 3"
Core cross-section . . . . .	1½" x 1½"	1¾" x 1¾"	2½" x 2½"

Note 1.—In the case of the 2200 watt transformer for two 250-watt tubes, the 220 volt supply is recommended. For 110 v. operation, in lieu of 220 v., wind primary in two sections and connect in parallel, or wind with half the above number of turns with copper ribbon ¼" x ⅜" cross-section.

Note 2.—Either 3 strands of the primary wire (No. 10 B. & S.) may be used in parallel, or copper strip of ⅜" x ⅙" cross-section.

effect is halved, so that although the secondary must be wound for double voltage (the full tube voltage between

the center tap and each end), the cross-sectional allowance is halved.

The theory of the thermionic rectifier is, so far as I am aware, unmanageable by means of the ordinary mathematics since the differential equations are inhomogeneous and irrational. Practically, however, a system designed to operate with a perfect rectifier will give the same results when this type of rectifier is employed.

**59. Construction of the Step-up Transformer.**—Sufficient data for the construction of transformers for supplying

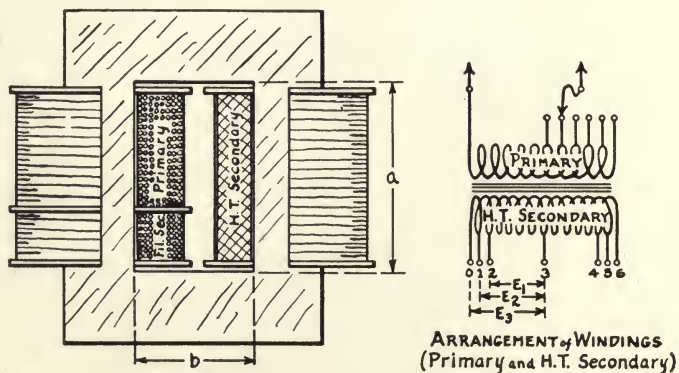

Fig. 97.—Arrangement of windings and plan of step-up transformer.

four 5-watt, and two 50- and 250-watt tubes, including a secondary for supplying the filament current, will be found in TABLE II on p. 167. The electrical connections and arrangement of the windings, and the general plan of the transformer are illustrated in Fig. 97.

In making the small computations for TABLE II, no attempt has been made to attain a most economical or efficient design, neither of which can proceed without

special data as to the materials to be used, the magnetic characteristics of the iron, etc.

The primary winding is preferably tapped at six points as indicated, the purpose of this being to provide an adjustment of the filament current without a filament rheostat, which costs money and wastes power. These taps may be brought out to a suitable rotary switch, as indicated in the diagram, for convenient adjustment. The filament secondary is wound upon the same core-leg as the primary, and except with unusual circuits, an average amount of low tension insulation between the two and between them and the core will be sufficient. The filament secondary is tapped at the center. The high tension (h.t.) secondary is arranged with a center tap, and subdivided so that three different voltages between the center tap and taps 0, 1, 2 on one side, and 4, 5, 6 on the other side, may be obtained. This arrangement may be necessary in changing from self-rectification circuits to those employing separate rectifiers, or in changing from the thermionic to the chemical and mechanical types of rectifier. The h.t. secondary winding should, of course, be well insulated from the core and ample clearance should be allowed between this coil and the primary and filament windings on the opposite core-leg. A 60-cycle, 110 or 220 volt supply has been contemplated in the design.

**60. Design of the Filter Circuit.**—Examination of Fig. 96, in which the amplitudes of the various harmonic constituents of the "equivalent voltage," (b) Fig. 95, have been represented, shows that a filter which will eliminate all frequencies above 100 cycles is needed. A very elaborate and effective network for this purpose is the Campbell

arrangement of recurrent equal sections of series inductance and shunt capacity. This network is shown schematically in Fig. 98 and is referred to in the classification of Prof. G. W. Pierce\* as of *Type II*, or in engineering parlance as a "low pass" filter.

This arrangement requires a number of coils and condensers and will be rather expensive to construct. For this reason we shall be content to mention it as the theoretically proper network, abandoning its further consideration in favor of simpler arrangements employing a few coils and condensers. The sophisticated reader who wishes

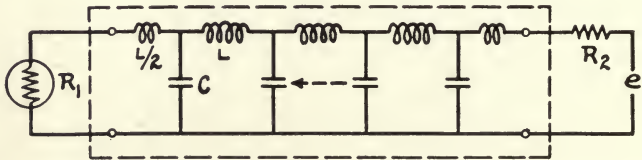

Fig. 98.—Electrical filter circuit of the Campbell type for suppressing currents of high frequency.

to undertake the design and construction of such a filter is encouraged to do so and will find plenty of theoretical guidance in Chapter XVI of Prof. Pierce's book previously referred to; but the average experimenter will, I believe, be satisfied with the less perfect but still quite satisfactory action of a simpler system.

At first sight it might appear that the most desirable filter would be one whose impedance at the various frequencies would be adjusted to suppress the harmonics in proportion to their amplitudes. This would indeed give a

\* Cf. Pierce: "Electric Oscillations and Electric Waves," p. 299 (New York, 1920).



uniform reduction of all frequencies, but this is not particularly desirable for two reasons, as follows:

In the first place, the higher frequencies have a relatively greater disturbing effect than the lower ones, that is to say, for a given amplitude the 240-cycle and higher frequencies produce more interference with the voice waves than the 120-cycle component. So the higher harmonics should ultimately be smaller than the lower ones. The second reason why the impedance should not fall off with increasing frequency is appreciated immediately if the problem is looked at from the viewpoint of Heising modula-

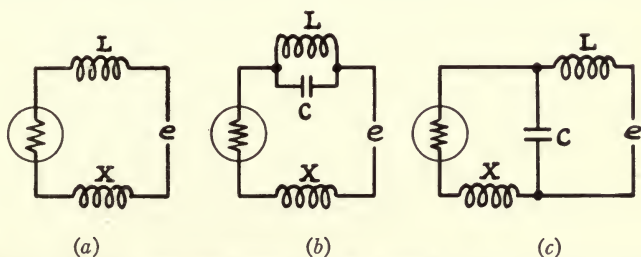

Fig. 99.—Symbolic representation of three simple filter circuits for use with step-up transformer and rectifier.

tion, Fig. 86. The transformer-rectifier-filter system is in series with the modulation choke-coil in that circuit, and obviously no reactances should be introduced in this system which will with the inductance of the choke-coil cause the impedance of this path to fall much below the value of 4000 ohms which we have prescribed. Thus the problem of design must be looked at from both ends of the telescope, and in this particular arrangement of circuits and rectifiers will not have the same aspects when so viewed.

Three simple filtering arrangements are shown symbolically in Fig. 99.

*Arrangement (a).*—In the first arrangement a single choke-coil is inserted in series with the circuit; and a single coil incorporating the modulation choke-coil is recommended. The choking action decreases with the frequency and the inductance should be large enough to give effective filtering action with the 120-cycle harmonic. An inductance of 10 henries will suppress one-half of this harmonic (representing a fluctuation of 25 per cent. of the d.c.), 20 henries will suppress three-fourths of it (12 per cent. fluctuation), and so forth. Coils of from 50 to 100 henries are not too large for this purpose, neither is their construction

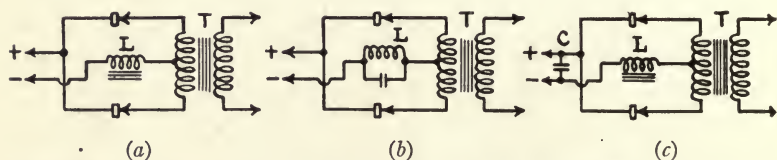

Fig. 100.—Showing actual connections in the three simple filter arrangements illustrated in Fig. 99.

particularly difficult. An air-gap should be provided, as in the case of the 6-henry modulation choke described in Fig. 88. Data for the construction of a suitable high-valued coil will be given in the next article. The actual connections are shown in Fig. 100 (a). The (+) wire connects to the plates of the tubes (no extra modulation choke necessary) and the (–) wire connects to the midpoint of the transformer filament winding. It is important to note that this system is *not* suitable for modulation by the grid voltage method. In this case the effect of the impedance in the plate circuit opposes the changes in the plate current that we are trying to cause by varying the grid voltage.

*Arrangement (b).*—The next step in improvement and complication consists in shunting the choke-coil of arrangement (a) with a condenser as shown at (b), Fig. 99. This is merely a symbolic representation, for the capacity at  $C$  may be the inherent distributed capacity of the choke-coil itself, or may be due to the combination of this and an external capacity. In its most desirable form this inductance and capacity would consist merely of a coil upon which wire had been wound until its natural frequency was 120 cycles, provided, however, that the inherent capacity does not exceed certain limits to be prescribed. At the frequency for which  $LC$  are resonant the branch circuit formed by them will offer a very high impedance, and as the frequency is increased from this point the impedance will decrease; at 4000 cycles the circuit will act very much like the condenser  $C$ . Thus we have here many of the features shown to be desirable, viz., a high impedance at 120 cycles falling off not too rapidly and never falling below 4000 ohms throughout a range of speech frequencies from 100 to 4000 cycles. In order for this last statement to be true a maximum capacity of .01 mfd. at  $C$  will be necessary, and with this capacity an impedance of 4000 ohms at 4000 cycles will be obtained, giving, as explained in Art. 53, a 90 per cent. modulation effect.

The practical features demand, however, some consideration. For resonance at 120 cycles with a capacity of .01 mfd. an inductance of 200 henries is required. Such a large coil would be impractical and the heat losses would vitiate to a large extent the improvement in the filtering action. We must, therefore, either sacrifice something in modulation and increase the capacity  $C$  (double it, let us

say); or not preferring this, sacrifice some of the choking effect at 120 cycles and tune the circuit to a higher frequency, for example, 240 cycles. By doing the first we reduce the inductance required to 100 henries, by the second to 50 henries, and by both to 25 henries. Somewhere in this range a practical set of values may be found which represent the best compromise between the operator's constructive energy and his desire for perfection.

Up to this point the design has been governed by the requirements of the Heising modulation system. For ordinary c.w. work this problem vanishes, and we have merely to design an effective filter system. In these circumstances a larger capacity at  $C$  may be used, allowing some reduction in the amount of inductance required in the choke-coil. This should not be carried too far, for the higher frequency quenching action will be impaired.

The actual connections are shown in Fig. 100 (b). The condenser should be designed to withstand the full voltage between the midpoint and one end of the h.t. secondary. The construction of a suitable high-valued choke-coil will be described in the next article. The wires (+) and (-) connect respectively to the plates of the tubes and the midpoint of the filament secondary. It is unnecessary to provide a separate modulation choke-coil; in fact, the addition of any inductance in series with the plate supply circuit will be deleterious. If properly designed this system of filtering will give excellent results and is easily the best of the simpler arrangements. The adjustment is not difficult, for the operator may listen-in on a local receiving apparatus or with a pair of telephones inductively coupled to the common lead (+) to the tubes, and vary the capacity

$C$  or the width of the air-gap in the choke-coil, until the 120-cycle or 240-cycle notes have their minimum intensities.

Like the previous arrangement this system is not well adapted for use with grid modulation on account of the high impedance in the plate circuit. The operation with this method of modulation may be improved by employing in the filter a large ratio of capacity to inductance.

*Arrangement (c).*—This very popular form of filter is mentioned here because of its popularity, because it is fundamentally wrong in principle and because if not properly designed it will do more harm than good. The condenser  $C$  is in this case shunted across the load, as shown in Fig. 99 (c).

Considering first the c.w. arrangement in which the modulation choke-coil  $X$  does not appear, we may formulate the following rule for proportioning  $L$  and  $C$ :

*Starting with the simple choke-coil arrangement, (a) Fig. 99, the addition of a condenser, as at (c) Fig. 99, will reduce the choking action on all frequencies lower than the frequency  $n$  unless its capacity is greater than  $1/2\pi^2n^2L$ .*

Considering the 120-cycle harmonic as of most importance this means that if the product of  $L$  in henries and  $C$  in microfarads is less than 3.5 the addition of  $C$  will magnify the 120-cycle ripple; if the product is equal to 3.5 it will have no effect on it (although the higher harmonics are more effectively choked); and in order to effect an improvement at 120 cycles the product should be greater than 3.5. This critical value for  $C$  may be determined by listening-in to the effect of adjustment of  $C$  or the air-gap

of the choke-coil. I believe that a great majority of the failures of this filter system can be explained as due to violations of the above fundamental rule, which is not empirical, but based on the mathematical theory of the circuit, and should be rigidly adhered to.

Now from the point of view of telephony, first with Heising modulation, if the modulation choke-coil  $X$  is omitted, the system will give the same results as arrangement (b) provided the same conditions obtain, viz.: that  $C$  does not exceed .01 mfd. In view of the rule just stated this will demand an inductance of 350 henries. Thus we are justified in condemning the system on two counts, as a defective filtering arrangement whose principle is entirely wrong, and as eminently impractical from the Heising modulation viewpoint. From the latter viewpoint also the extra choke-coil  $X$  should always be omitted.

The arrangement does, however, have a slight appeal if we consider it from the viewpoint of grid voltage modulation. As already remarked, in order for this system of modulation to be successful the plate circuit should contain no telephone-frequency reactance. In this respect it is quite the reverse of the Heising method, which for best operation demands a maximum reactance. Thus the arrangements (a) and (b) which were found suitable for the latter method, will give poor results with grid modulation. The present arrangement is slightly more effective in this respect. Still keeping the  $LC$  product above 3.5 we may increase the ratio of  $C$  to  $L$  until the reactance  $1/2\pi nC$  is sufficiently low. With a capacity of 2 mfd. the effective reactance from the plate circuit point of view at the lower limit of the speech frequency, 100 cycles,

will be about 700 ohms; at 4000 cycles it will be about 17.5 ohms. There will be some reduction of the lower frequencies, but the operation may be considered satisfactory. Grid modulation is principally an economical method and will be employed most extensively with the 5-watt tubes. In this case the voltage which the shunt condenser  $C$  must withstand is relatively low (1000 volts max.) and commercial forms of paper condensers may be grouped in series and parallel until the required breakdown voltage and capacity is obtained. With a capacity of 2 mfd. an inductance of at least  $3.5 \div 2 = 1.75$  henries should be used; 25 or 50 henries will be better.

The actual connections of this circuit are shown in Fig. 100 (c). The wires (+) and (-) connect to the plates of the tubes and to the midpoint of the filament secondary respectively.

**61. Résumé: Comparison of the Filter Circuits.**—Of the preceding arrangements, considering their merits as filters and from the viewpoint of modulation, the arrangement (b) Fig. 99 is regarded as the best for Heising modulation, with (a) next in order, and (c) as inherently and practically unsuitable for this method of modulation, but more suitable than the others for grid voltage modulation.

In applying (a) and (b), the inductance should be at least 50 henries, and in the case of (b) the total capacity across the coil, including the distributed capacity of the coil windings, should not exceed .01 or, possibly, .02 mfd.

In applying (c) for grid voltage modulation the ratio of  $C$  to  $L$  should be as large as possible and the product

of  $L$  in henries and  $C$  in mfd. should not be less than 3.5. A minimum capacity of 2 mfd. is suggested for  $C$ , and an inductance of 25 or 50 henries for  $L$ .

**62. Construction of the Filter Apparatus.**—The filtering arrangement (*b*) utilizes a 50-henry choke-coil and a .01 to .02 mfd. condenser. It will be helpful, I think, to indicate briefly how these electrical constants may be practically attained.

(a) **50-Henry Choke-coil,  $L$ .**—This coil carries normally the steady d.c. for the tubes and should be carefully designed so that the iron is not operated at too high a flux-density. An air-gap is the most convenient means for preventing this, and may be made adjustable so that the inductance of the coil may be varied for experimental purposes. A greater variation of inductance can be secured by varying the number of turns and taps may be brought out at intervals for this purpose. In the 12,500 turn coils to be described, it is suggested that taps be made at 6000, 8000, and 10,000 turns. The arrangement of coils and the general plan of the windings and core are similar to those of the 6-henry modulation coil described in Fig. 88. Data for the construction of coils for two 5-, 50- and 250-watt tubes are given in TABLE III on p. 179.

Instead of the arrangement shown in Fig. 88, the top core-leg in which the air gap is cut may be made in a solid piece, hinged at one end and separated from the other end by an adjustable air gap. The mechanical arrangement of this will be left to the reader. Since the coil may be subjected during modulation to voltages equal to twice the normal tube voltage, the insulation of the winding should be carefully attended to.



TABLE III

SPECIFICATIONS FOR 50-HENRY CHOKE-COIL FOR FILTER ARRANGEMENTS  
(a) AND (b), FIG. 100

Power Rating of Tubes.	5 w.	50 w.	250 w.
Normal direct current.....	0.1 amp.	0.3 amp.	0.6 amp.
Conductor (B. & S. gauge).....	No. 30	No. 24	No. 22
No. turns (total).....	12,500	12,500	10,000
Amount of wire required.....	2 $\frac{1}{8}$ lbs.	16 lbs.	25 lbs.
Core dimensions; (a x b).....	3" x 2"	4" x 3"	5" x 3"
Core cross-section.....	1" x 1"	2" x 2"	2 $\frac{3}{4}$ " x 2 $\frac{3}{4}$ "
Width of air gap.....	$\frac{1}{8}$ "	$\frac{3}{8}$ "	$\frac{3}{4}$ "
D.c. resistance (ohms).....	660	500	200
Heat loss (watts).....	6.6	45	75

Note.—For arrangement of windings and notes on design, see Fig. 88.

(b) 0.02 Mfd. Condenser, C<sub>o</sub>.—The condenser is subjected to the same voltages as the choke-coil and its dielectric should be selected with this in mind. The capacity required is not large, so the use of glass plates is convenient. The design of a glass plate condenser has already been considered in Art. 44 (b); and with the plate and conductor dimensions there given a total of 81 plates will be required. It will be better to use 8" x 10" photographic plates, which average about 0.06" ( $\frac{1}{16}$ " ) in thickness. They may be covered with tin-foil 6 $\frac{1}{2}$ " x 8 $\frac{1}{2}$ "; and using the formula of Art. 44 we find that the capacity per positive plate is .0019 mfd. A total of 11 positive and 12 negative plates will, therefore, give the required capacity.

63. Construction of a Chemical Rectifier.—The chemical rectifier is cheap and easy to construct and gives quite satisfactory service. It usually consists of an electrolytic cell formed by an electrode of aluminum and an electrode of lead or other metal immersed in a concentrated solution

of borax ( $\text{Na}_2\text{B}_4\text{O}_7$ ) and water. It is found experimentally that at ordinary temperatures such a cell possesses the valuable property of permitting the flow of current from the lead to the aluminum electrode, but for limited applied voltages checks the flow in the opposite direction. If the voltage, applied in the direction for which the cell is non-conducting, exceeds a certain critical value, determined by the electrochemical properties of the solution (480 volts for borax), the thin film of gas on the aluminum electrode which prevents the flow of current, breaks down and the current is no longer impeded. It is necessary, therefore, in using this type of rectifier with high voltages to use several cells in series, the number being so chosen that the peak value of the alternating voltage does not exceed this critical value in any cell, for obviously (see Fig. 100) the entire voltage between midtap and the end of the transformer is impressed across the rectifier during the non-conducting period. The voltage at which the film breaks down, and the cell ceases to rectify, is reduced also by a rise in temperature; hence an ample amount of solution should be used in order to dissipate the heat, and the electrode surface should not be too small. There is, in fact, an optimum electrode surface per ampere, which represents the best compromise between getting a low resistance during the conducting period and a ready formation of the barrier gas film for the non-conducting period. If the electrode surface is too large, the formation of the film is impeded.

Unfortunately, because they have no special applications in the general electric practice and have, we might say, but lately come into vogue on account of their suitability for the supply of high voltages for audions, there

is but little engineering data in the literature on the subject of chemical rectifiers. The following remarks on the design and construction of the chemical rectifier has therefore no sounder basis than a limited number of experiments and a collation of the published experience of others.

The number of cells will be determined by the maximum voltage (equal to r.m.s. value  $\times$  1.4 for sine wave) between the midpoint and the end of the h.t. secondary of the transformer; and allowing a maximum voltage of 150 volts per cell the number of cells in the three cases are as given in TABLE IV. As for the current density, from 5 to 10 sq. in. per ampere appears to be common practice, and the data in TABLE IV is based upon an average value of 7.5. There is no optimum value for the quantity of solution required; for proper cooling this should be as large as possible.

TABLE IV

DATA FOR THE CONSTRUCTION OF CHEMICAL RECTIFIERS FOR USE WITH TWO 5-, 50-, AND 250-WATT TUBES

Power.	Normal d.c.	Electrode Area of Immersion.	No. Cells Each Bank.	Voltage (r.m.s.).	Quantity of Solution.
5 w.	.1 a.	2" x $\frac{3}{8}$ "	6	550	$\frac{1}{2}$ pt.
50 w.	.3 a.	3" x $\frac{3}{4}$ "	12	1100	1 pt.
250 w.	.6 a.	6" x $1\frac{1}{4}$ "	24	2200	1 qt.

The solution is made by dissolving as much borax (the "20 Mule Team" variety will do) as possible in cold water and using the clear liquid. After the electrodes are in place a supernatant layer of oil from  $\frac{1}{4}$ " to  $\frac{1}{2}$ " thick should be placed on the electrolyte to prevent its evaporation and loss during operation, and to check the tendency for arcing from the unimmersed portions of the aluminum

to the electrolyte. The oil should be heavy enough not to emulsify, but not heavy enough to prevent the free escape of gas from the electrodes.

The sharp edges of the electrodes may be rounded in

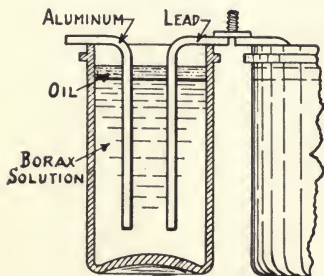

Fig. 101.—Illustrating construction and arrangement of cells in chemical rectifier.

their immersed portions and the metal should be well cleaned, first with sandpaper or by scraping, and then by boiling in a solution of caustic potash and scrubbing to remove all traces of grease. A mechanical arrangement of cells is shown in Fig. 101 and the electrical connections are illustrated in Fig. 102 in relation to the transformer-rectifier-filter scheme of Fig. 100 (b).

The cells should be placed in trays which have been carefully insulated from each other and from the earth by

porcelain "knob" or other available insulators. The trays are best coated with paraffine and kept dry to prevent leakage.

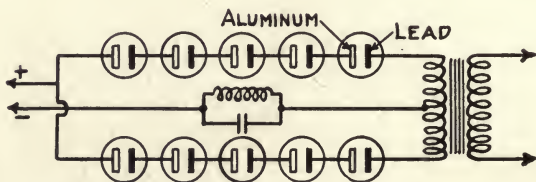

Fig. 102.—Electrical connections of chemical rectifier, step-up transformer, and filter circuit suitable for Heising modulation.

porcelain "knob" or other available insulators. The trays are best coated with paraffine and kept dry to prevent leakage.

In putting a new rectifier into operation the plates may be "formed" or seasoned by operating them in series with a few electric lamps on the 110-volt mains. The best re-

sults are obtained if the process is carried out with a sub-normal current density, say at about 50 per cent. of their rated current. After about six hours' continuous operation the aluminum plate will be found covered with a light gray oxide, and the lead plate will have turned a very dark brown color. They may then be connected in their normal mode and further seasoned by operation.

**64. Thermionic Rectifiers.**—The fundamental principle of this type of rectifier has already been explained in Chapter II. It consists of a plate electrode and a filament, both enclosed in a glass bulb *in vacuo*. The filament emits electrons when heated and the device possesses the important property of permitting current to flow from plate to filament, but not in the opposite direction.

Thermionic rectifiers are less efficient and more expensive, both in first cost and maintenance, than the chemical type. The smaller efficiency results both from a lower rectification efficiency, that is, a larger loss in the rectifier, and from the extra power consumed by the filament. This latter is a pure loss, since the filament contributes nothing directly to the rectification process. The maximum overall efficiency of the usual commercial type of rectifier is about 40 or 50 per cent. Thermionic rectifiers are, however, of considerable commercial and military value, and may also be found convenient by amateurs in situations where the messier jars and solutions of the chemical type are unsuitable, as in portable installations.

Several types are available on the market and are sold under various trade names as "Kenetrons," "A-P" tubes, etc. These are manufactured in various sizes appropriate to the 5-, 50- and 250-watt tubes previously described.

The connection of a typical thermionic rectifier set is shown in Fig. 103, in relation to the filter scheme (b), Fig. 100. The filaments are supplied by the transformer  $T_2$ , or by a separate winding on the power transformer,  $T_1$ . It is to be noted that the filaments of the rectifier tubes are at the average potential of the plates of the power tubes, and the apparatus connected to them, filament rheostats, meters, switches, etc., and the filament winding

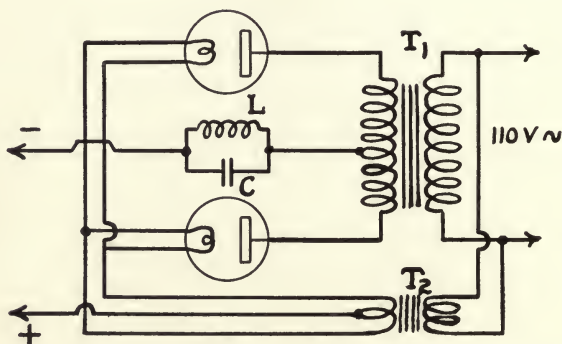

Fig. 103.—Illustrating connections for thermionic rectifier, step-up transformer and filter circuit.

of the transformer should be carefully insulated, and shielded from accidental contact.

**65. Mechanical Rectifiers.**—Mechanical rectifiers are simply automatic switches which reverse the direction of the current in synchronism with the alternating supply voltage. They are chiefly of two types, classified according to the means adopted for actuating the reversing mechanism, as of the vibrating type and the synchronous commutator type. The first arrangement employs a vibrating reed which is acted upon by an a.c. magnet connected to

the current source; the second type consists of a reversing commutator driven by a synchronous motor.

Because of the difficulty in controlling the time and duration of contact, vibrating rectifiers have not been successfully applied in high voltage low current systems of the type under consideration. They are chiefly useful for charging storage batteries, and for other purposes where low voltages are involved.

The synchronous commutator is more suitable for the rectification of high voltages because the time of making contact and its duration is under better control. A synchronous motor is necessary, and if the reader is fortunate enough to have possessed a synchronous spark gap, its motor may now be pressed into service. The system of constant-potential rectification\* seems to be most suitable and is illustrated schematically in Fig. 104, in relation to the filter scheme of Fig. 100 (b). The rotating disc is provided with two sets of segments, connected respectively to the terminals of the h.t. secondary of the supply transformer. The connections are made by means of slip-rings and brushes of the usual type. The commutator is preferably of large diameter so that the brushes may be sufficiently large for mechanical rigidity without covering too great an electrical angle. The full secondary voltage will exist between the consecutive segments and this should be kept in mind in designing the insulation. This arrangement will be successful for use with 5-watt tubes, and by careful design may possibly be applied to the higher powered types.

\* Cf. C. P. Steinmetz: "Transient Electric Phenomena and Oscillations," p. 236 (New York, 1909).

Considering the design of a disc for use with a synchronous 60 cycle 110 volt single phase motor, with synchronous speed of 1800 R.P.M., four segments will be required, two for each cycle. Allowing a maximum voltage at interruption of 15 per cent. of the peak value, a disc diameter of 8 inches will be indicated. The width of the insulation segment should not be greater than  $\frac{5}{8}$  inch. The brushes of each set are, of course, separated by the same distance.

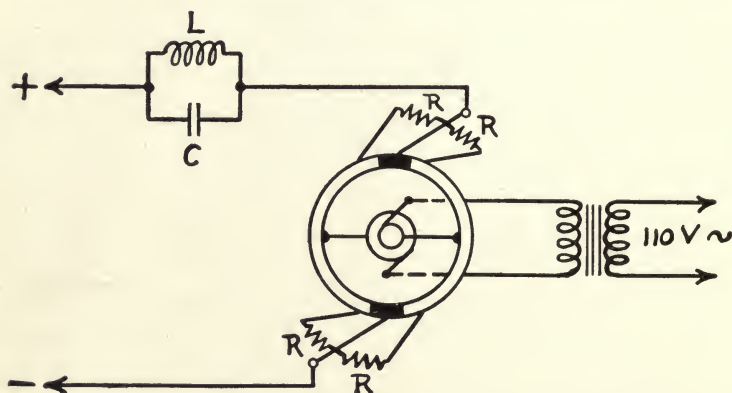

Fig. 104.—Illustrating constant-potential mechanical rectifier using synchronous commutator.

These may be of wire and have a rectangular cross-section, narrow in the direction tangent to the disc. The function of the resistances  $R$  is to control the change of current and prevent sparking. For a load of two of the standard types of tubes, a value of 5000 ohms will be sufficient. Since the current exists but a short time, and at a time when the voltage is low, ordinary grid leak resistances, of the type used with the 250-watt tubes will be convenient. These are usually of 10,000 ohms resistance, with a center-



tap at 5000 ohms. The mechanical arrangement, including the provision of a means for shifting the brushes so that commutation takes place at the time of minimum voltage, is left to the reader. The type of commutator described by the writer in "Modern Electrics" for January, 1911 may be more convenient than a construction embodying separate slip-rings. It is to be noticed that in a constant-potential system of commutation, as here described, the commutator simply reverses the supply voltage and the current in the load circuit will be determined mainly by the characteristics of that circuit. Thus the method of filter design previously employed will be appropriate in this case also.

**66. Motor-generators.**—The motor-generator is without doubt the most reliable source of high voltage d.c. for the plate circuit of power tubes. This is especially true with the higher powered tubes such as the 250-watt type, where suitable chemical rectifiers, involving as specified in TABLE IV a total of 48 cells, are somewhat unwieldy. The disadvantage of this source of supply is, from the amateur's point of view, its high initial cost. Several types of generators with d.c. or a.c. motors are available on the market, capable of supplying enough power for groups of 5-, 50- and 250-watt tubes.

It is often possible to rewind low voltage motors or generators to deliver the required voltage. This cannot be carried too far unless the insulation of the commutator is designed to withstand high voltages. Old 500–600 volt d.c. motors, such as are employed for auxiliary purposes, for air-pumps, etc., by street-railway companies are very useful, already having well-insulated commutators, and,

of course, being suitable without rewinding for the excitation of the 5-watt tubes.

While the voltage supplied by a d.c. generator is substantially constant, a high frequency commutation ripple or "hum" will often occur, due to faulty commutation or other more natural causes. This may be removed by a proper filter; and a proper filter for Heising modulation does not consist in shunting the generator with a 1 mfd. condenser, or any reactance which with the reactance of the modulation choke-coil will give a lower impedance than 4000 ohms at frequencies in the speech range. This is a common error, and I know at least three large broadcasting stations where the modulation in the lower range suffers from this species of malpractice. When Heising modulation is used a 50-henry choke-coil in series will effectively subdue the ripple and improve the quality of the speech at the same time.

**67. Complete Wiring Diagrams for Transmitters.**—In concluding this section on the transmitting apparatus, in which the various parts, oscillating circuits, modulator, power supply, etc., have been considered separately, it seems worth while to indicate the method of combining the various parts into one complete wiring diagram. This will be illustrated for a model amateur transmitter, using the Meissner Transmitting Circuit No. 1, the Heising system of modulation, Fig. 89, the transformer-rectifier-filter scheme of Fig. 100 (b), and the method of combining direct earth and counterpoise to reduce earth losses, described in Art. 26. In addition, switches are to be provided so that the modulation tube may be connected in parallel with the oscillator tube for c.w. operation. The

FIG. 105

COMPLETE WIRING DIAGRAM FOR SPECIMEN RADIO TRANSMITTER USING  
 MEISSNER CIRCUIT, TRANSFORMER-RECTIFIER-FILTER METHOD OF PLATE SUP-  
 PLY AND HEISING MODULATION, ARRANGED FOR EITHER RADIO TELEPHONY  
 OR C.W. TELEGRAPHY.

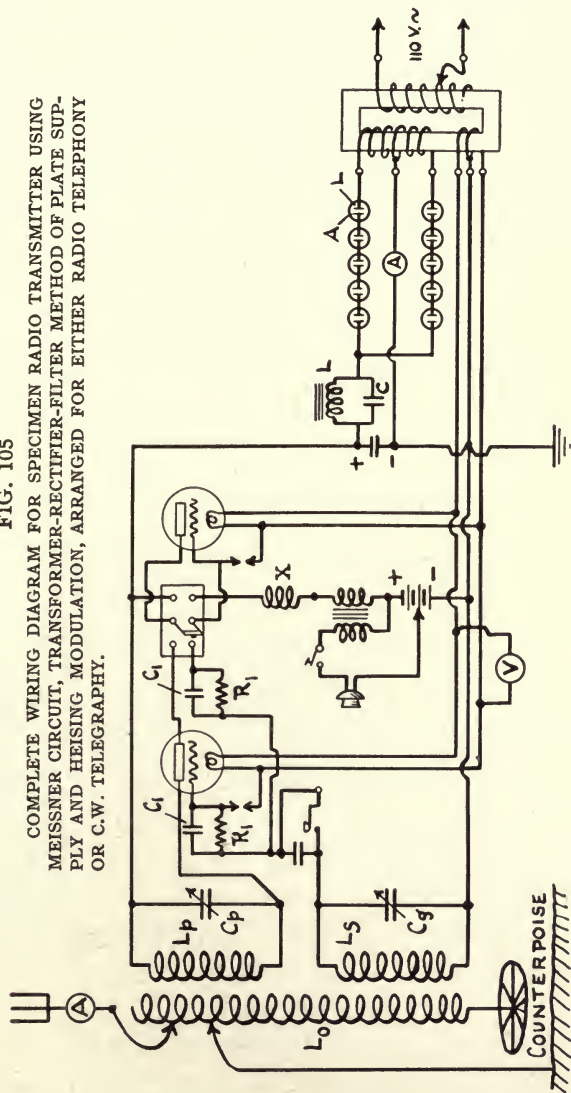

complete wiring diagram is shown in Fig. 105, and is suitable for two 5-, 50- or 250-watt tubes, with proper circuit constants and apparatus as completely specified in the diagrams and tables of the last two chapters.

**68. Assembly of the Complete Transmitter.**—It is suggested that the various parts described in the preceding articles be assembled in a complete transmitting unit, as in the specimen transmitting set illustrated in Fig. 106.

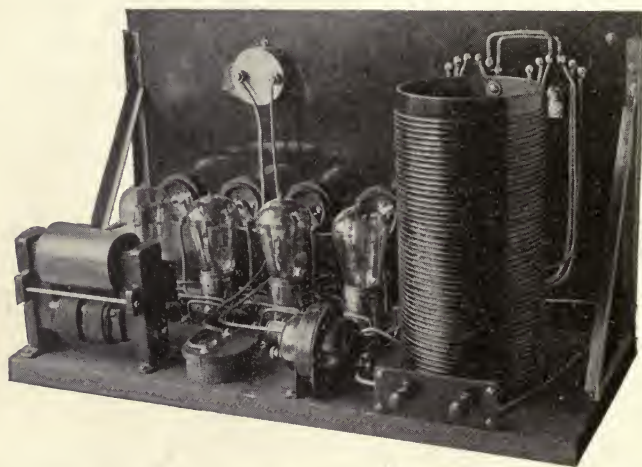

*Fig. 106.—Complete low-power radio telephone and c.w. transmitter.*

This shows a 20-watt set, employing four 5-watt Radiotron power tubes. The 60-cycle power transformer is shown at the left, the radio frequency choke-coil to the right of this, then the low frequency filter circuit choke-coil, and to the extreme right the antenna coil, which is in this case wound with solid round copper wire, spaced to reduce the resistance. Taps are taken from this coil to the switches on the front of the panel, for the control of the wavelength and the adjustment of power output.

## CHAPTER VI

### RECEIVING APPARATUS

**69. Main Processes in the Reception of Radio Telephone Signals.**—Reference has already been made (Art. 9) to the fact that the radio telephone receiver consists essentially of two parts; (*a*) an apparatus for tuning the antenna circuit to the wavelength of the signal to be received, and (*b*) a detector or demodulator, whose function it is to translate the radio frequency waves into the low frequency vibrations of the speech or other transmitted sounds. In more elaborate receivers, in addition to these essential parts, amplifiers may be provided to magnify the radio frequency waves previous to detection, or to magnify the audio frequency vibrations after detection, either to secure greater response in the telephones or for the operation of a loud speaker. Cascaded audion amplifiers are generally used for this purpose.

There is some didactic advantage, I think, in partitioning the receiving equipment into parts according to the distinct functions of these parts, and not only does this apply to the written description and treatment of the system, but may also extend to the actual assembly and construction of the apparatus. As applied in the construction, the above four-part division constitutes a compromise between the German method of mounting all parts of the receiver in one cabinet, and the English method of keeping every part separate. The treatment of the re-

ceiving apparatus given in this chapter will proceed in this spirit, but at the same time we shall consider the combination of the units into receivers of various degrees of pretentiousness.

**70. The Tuning Apparatus. Single-circuit and Double-circuit Receivers.**—The purpose of the apparatus which we have designated as the “tuning apparatus” is twofold: first, to reduce by the insertion of proper amounts of inductance and capacity, the impedance of the antenna circuit to its lowest value at the wavelength of the signal to be received, so that the current flowing in the circuit will be a maximum; and second, to provide the proper transformer action for transferring the greatest amount of energy from the antenna circuit to the detector. These functions are, in the main, independent. Concerning the latter, it should be noted that the audion detector or amplifier is a potential controlled device and demands a high voltage and small current for its operation; whereas the crystal detector requires a somewhat larger current. According to the two principal methods used for the transfer of energy from antenna circuit to detector (or amplifier), receivers are classified as of the *single-circuit*, or *double-circuit* types. These types are illustrated in Fig. 107. In the single circuit arrangement (*a*), the inductance  $L_0$  and capacity  $C_0$ , either of which or both may be variable, are used to tune the antenna circuit. The detector or amplifier is connected across the inductance  $L_0$  and is actuated by the voltage drop across it. For wavelengths below the fundamental of the antenna, the detector or amplifier is preferably connected across the tuning condenser  $C_0$ . In the usual practical application the inductor  $L_0$  consists of a coil, tapped at certain intervals

to provide a means for roughly adjusting the inductance. The finer tuning is accomplished by means of the variable condenser. The proper transformation ratio is obtained by varying the proportion of inductance and capacity, keeping their combined reactance constant, of course, to preserve resonance with the induced voltage.

In the double-circuit arrangement (b), Fig. 107, the coupling is inductive and both circuits are to be tuned to the incoming wave by means of the adjustable inductances

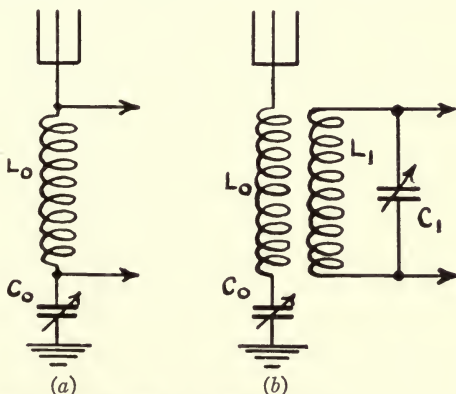

Fig. 107.—Schematic illustration of the single-circuit (a) and double-circuit (b) methods of tuning.

and capacities. The detector or amplifier is in this case connected across the secondary condenser. The transformation ratio is adjustable by means of the coupling as well as by varying the ratio of inductance to capacity in the two circuits.

The single circuit receiver is the simpler of the two, in both construction and adjustment. For this reason it will be particularly attractive to beginners, and others of limited experience. But with the usual type of receiving

antenna, having a high resistance, it will be considerably less selective and efficient than the double circuit arrangement. In the first form (*a*) the voltage acting upon the detector or amplifier is inversely proportional to the antenna resistance; in the second (*b*) it is inversely proportional to the square root of the product of antenna circuit resistance and secondary circuit resistance. Thus in the form (*b*) it is possible, by building a secondary circuit of low resistance, to compensate to some extent for a poor antenna. In these days, when so many radio transmitters are operating in a narrow band of wavelengths, the increased selectivity of the coupled circuit is also an extremely important feature.

**71. Construction of the Tuning Apparatus.**—The tuning unit is preferably mounted in a cabinet by itself. For best results the coils should be constructed so that their losses are small. As stated above, if the receiving antenna is not good, that is to say if it is not carefully constructed to have low losses by the methods exploited in Chapter III, its resistance will be relatively high and any improvement of the tuning apparatus directly in the antenna circuit will not be particularly effective. In these circumstances it will be more profitable to devote attention to the improvement of the secondary circuit, using the coupled circuit arrangement of Fig. 107 (*b*). But the reader will make no mistake in minimizing the resistance of both circuits and the following notes may be of some assistance in connection with this.

The high-frequency resistance of a coil is higher than its resistance for steady currents and increases rapidly with the frequency (decreasing wavelength). This is due mainly to the crowding of the current toward the outside of the



coil at high frequencies, and to losses in the dielectric material used for its insulation and support. At certain wavelengths the first kind of loss may be reduced by winding the coil with a stranded conductor, or cable, made up of a number of smaller wires in parallel. But for wavelengths of the order of 100–500 meters with which we are here concerned, it has been found that solid wire, No. 18–22 B. & S. gauge copper, yields a coil whose resistance is lower than one wound with the usual commercial grade of r.f. cable.\* When using the solid wire (No. 18 is to be preferred) it is desirable to separate the turns by a distance equal to the diameter of the wire. This optimum spacing is very well defined for coils wound on cardboard tubes and with cotton-insulated wire. Variation of the inductance is usually obtained by tapping the coil at certain intervals and connecting these taps to a multi-point switch. In this case the fine tuning is obtained with a variable condenser. This is a convenience, and is justified only for this reason, for electrically it is bad practice. In the first place it leaves unused portions of the coil more or less closely coupled to the active portion, and in these unused turns induced currents will cause a loss and increase of the resistance of the main circuit (“dead-end” effect). Secondly, the taps being brought out to the multi-point switch on a bakelite or other panel, produce a very substantial dielectric loss. This can be reduced in several ways: by eliminating the switch entirely and using clips on a coil which

\* This fact, as well as other statements of this section, rests upon the extensive and unpublished experimental study of the losses in radio coils made by my former colleagues, Messrs. L. B. Dick, W. G. Ellis and W. D. Loughlin of the U. S. Navy, to whom I am indebted for placing their results at my disposal.

has been tapped as shown in the middle inductor of Fig. 8, or by using great care in the construction of the switch. I have found the form of construction shown in Fig. 108 to yield very low switch losses if the mica plate is carefully selected. The accompanying figure conveys the important details of this construction. The panel is cut away and for it is substituted a sheet of good electrical mica, barely thick enough to give good mechanical support. Mica varies a great deal in its electrical properties and unless

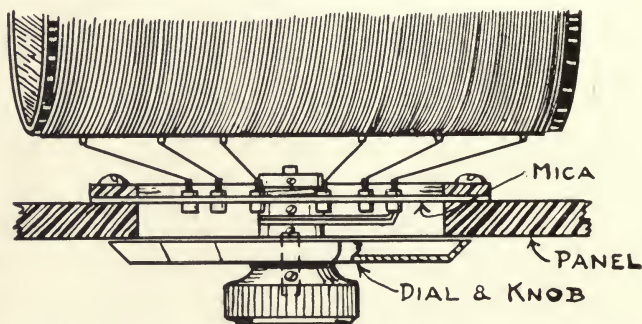

Fig. 108.—Illustrating construction of mica-insulated switch, designed to reduce dielectric losses with tapped coils.

this sheet is selected with great care, the whole purpose of the special construction will be defeated. The switch is of the usual rotary type, but in which the contact points are very small ( $\frac{1}{8}$ " diameter with 3-48 studs). "Spaghetti" or other insulation is not to be used on the wires leading from the coil to the switch. These should be heavy, about No. 16 B. & S. bare copper wires, and self-supporting. Another scheme for eliminating the dead-end and switch loss incident to the use of tapped coils, is to use separate coils of the proper inductance values for the wavelength

ranges to be covered. Two types of such coils have already been illustrated (Fig. 7). These are marketed in many forms and in all sizes from coils of a few turns to those containing 1500 and more. A special form of zig-zag winding is sometimes employed which renders the coil mechanically firm and self-supporting, and is claimed to reduce the distributed capacity and coil losses. The reduction of the distributed capacity increases the wavelength range, but this is of no importance; the principal result of reducing the capacity is that it diminishes the dielectric losses due to the tendency for the currents to forsake the inner turns, and flow by capacity paths toward the outer ones.

The above instructions are general and pertain to all radio coils in which a low resistance is to be obtained. As in the case of the antenna, I have outlined what appears to be the best practice, but do not want the unsophisticated reader to suppose that less elegant construction will not give satisfactory results. He may, if he chooses, omit the mica-insulated switches, and to space the turns on the coil, and so forth, and still hear good signals; but the more serious experimenter who takes pride in a job well done and who has a proper appreciation of the relative importance of various improvements, will want to have this information.

(a) **Single-circuit Construction.**—The single-circuit tuner consists of an adjustable coil and a variable condenser. When regenerative reception is undertaken by the “tickler coil” method (see Art. 73) an auxiliary coil is coupled to the antenna coil. In this case the double-circuit construction may be used, employing the secondary as the “tickler coil” and omitting the secondary tuning condenser. An example of this assembly is shown in Fig. 109, where the tapped

antenna coil and the antenna tuning condenser are clearly shown. For the average amateur antenna with a fundamental wavelength of 200 meters (including the single wire receiving antenna, Art. 36), a coil wound with from 60 to 90 turns of No. 18 copper wire on a tube 4" to 5" in diameter, tapped every 15 turns, will cover the con-

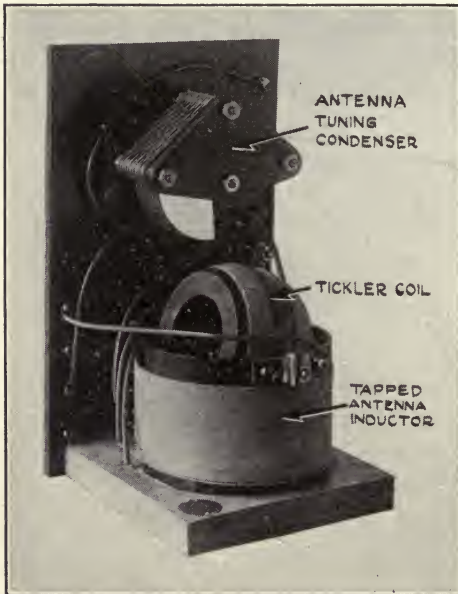

*Fig. 109.—Illustrating single-circuit tuner provided with tickler coil for regenerative amplification.*

templated wavelength range (150–600 meters). The turns are preferably separated by a distance equal to the wire diameter. A variable condenser having a maximum capacity of .001 mfd. is suggested for use with this coil. The connections of the single-circuit tuning unit are indicated in Fig. 110.

(b) **Double-circuit Construction.**—The primary circuit of the double-circuit tuner is arranged as described for the single-circuit scheme. The secondary consists of 50 turns of No. 18 d.c.c. wire wound on a 3" tube, and is arranged to rotate within the larger primary coil so that the coupling can be varied. This arrangement of coils is popularly referred to as a "vario-coupler." It is suggested that this coil be wound in a double layer, 25 turns on each side, and that a tap be taken out at 25 turns. Unless a double layer

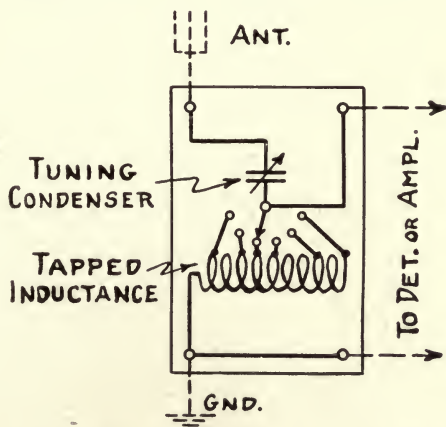

Fig. 110.—Electrical connections of single-circuit tuner.

is used the coil will be too long to be rotated within the 5" primary coil. Used in conjunction with a secondary tuning condenser of maximum capacity, .0005 mfd., the secondary coil will cover a wavelength range of 150–600 meters. The connections of the complete tuning unit are given in Fig. 111.

Sometimes the antenna variable condenser is omitted and the circuit tuned by means of an inductance alone. For operation above the fundamental of the antenna this

method is more efficient since it involves the introduction of no more wire (which has resistance) than is absolutely

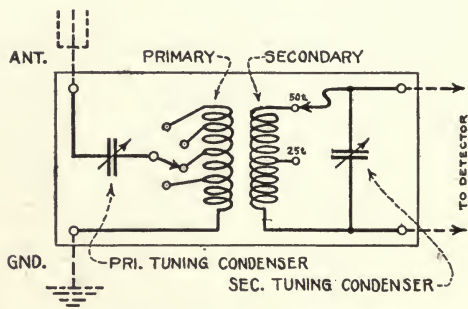

Fig. 111.—Electrical connections of double-circuit tuner.

necessary to attain the desired wavelength. The coil may be tapped every ten turns, and then tapped every single

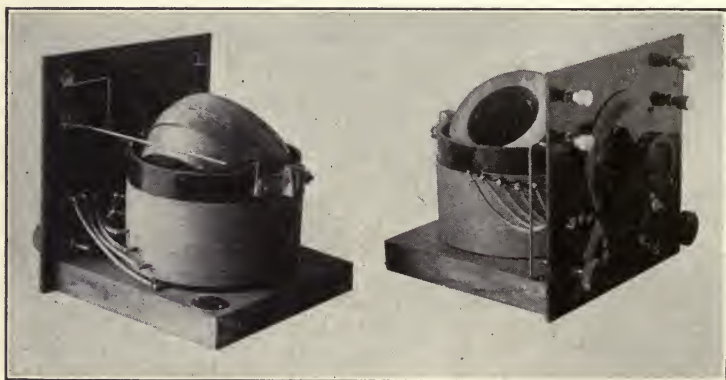

Fig. 112.—Type of vario-coupler for double-circuit tuning, using tapped primary coil.

turn for ten turns, to secure fine adjustment. An example of this form of construction is shown in Fig. 112. In this

case the coil is tapped every 7 turns (right hand switch) and every single turn for 7 turns (left-hand switch).

Another variation of the above tuning arrangement consists in eliminating the secondary variable condenser and tuning by means of a variable inductance (variometer). A few writers and manufacturers insist that this is a more efficient combination. Leaving aside the technical questions involved, the condenser scheme is considerably more satisfactory when regenerative reception or radio frequency amplification is attempted, and gives a quieter and more easily controlled receiver. This is sufficient to justify its recommendation in this book.

**72. Simple Type of Receiver Employing a Crystal Detector.**—The simplest detector of the modulated radio frequency currents used in radio telephony consists of a sensitive mineral or "crystal" upon which a contact is made with a metallic probe or another mineral. This combination possesses the important property of allowing more current to pass through it in one direction than in the other. The application of this property in the detection of radio signals will be obvious to the reader, and has been discussed in Chapter I. The connections of the crystal detector to the single-circuit tuner described in the preceding article are shown in Fig. 113.

Here *D* represents the crystal detector; *C* is a blocking condenser whose purpose is twofold: first, to shunt the radio frequency currents around the telephones, and second, to give the circuit the proper audio frequency characteristics for the emission of a smooth note by the telephones. A paper condenser of approximately .01 mfd. capacity will be indicated with the usual type of telephones. This

condenser is generally included in the crystal detector sets supplied commercially (Fig. 114), or can be easily constructed by the reader according to the following method: Cut out two strips of tinfoil 3 in. wide and 2 ft. long, and three strips of thin paraffined paper, 4 in. wide and 2 ft. 3 in. long. After pasting the tinfoil sheets on each side of one of the paper strips, sandwich the whole between the remaining two paper strips and roll it up, binding the roll

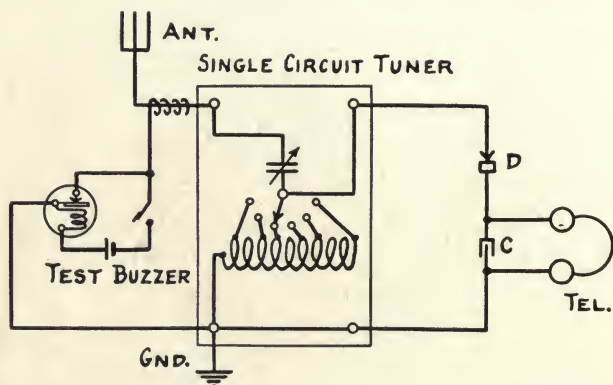

Fig. 113.—Electrical connections of simple receiving set, employing single-circuit tuner and crystal detector.

with tape or cord. Connections are made to the two tinfoil sheets. The telephone receivers require no description. At the left of the figure is shown a "test buzzer" which is to be used in adjusting the detector, that is, in probing the surface of the crystal for a sensitive spot. This consists of a radio buzzer operated by one dry-cell, from one of whose contacts a connection is made to the ground and from the other to a few turns of wire wrapped around, but no connected to, the antenna lead. The buzzer shocks the circuit



into radio frequency vibrations and when the detector is properly adjusted, the buzzer note will be heard in the telephones.

Several sensitive minerals are known, and these or combinations of them have been employed at various times in crystal detectors. The most satisfactory of these are: *galena* (lead sulphide,  $PbS$ ), used with a light steel spring contact; *fused silicon*, used with a sharp rather firm metallic

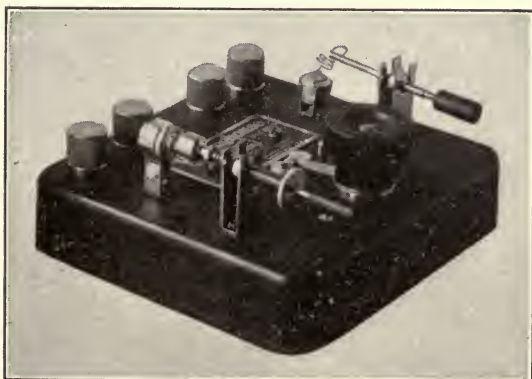

Fig. 114.—Commercial type of crystal detector set, providing two detectors with switch for including either of them in the circuit.

contact, or with a pointed probe made of *antimony*; the “perikon” combination of *zincite* (zinc oxide,  $ZnO$ ) and *chalcopyrite* (copper-iron sulphide,  $CuFeS_2$ ), often used with a biasing battery; and *carborundum*, used with a steel point, firm pressure, and a biasing battery. A typical commercial detector set is shown in Fig. 114. Here two detectors are provided, either of which may be thrown into the circuit by means of the small rotary switch. The blocking-condenser is in this set mounted in the base, the left-hand

pair of binding posts being connected to the tuner and the right-hand pair to the telephones.

The combination of single-circuit tuner and crystal detector just described constitutes a simple type of receiver which will give satisfactory response from broadcasting stations within a radius of five or ten miles, and will appeal to the beginner who is located within this distance and who wishes to make his *début* in the radio telephone field with a minimum of expense. In erecting the antenna, the latter part of Chapter III, particularly Art. 36, should be consulted; and lightning protection of the type prescribed by the underwriters (see Appendix A) should be provided.

**73. Regenerative Method of Amplification.**—Reference has already been made to the amplifying action of the audion, whereby small changes in the voltage of the grid are capable of producing substantial changes in the plate current. This property is utilized, as explained in Chapter II, in the application of the audion as a self-excited generator of alternating currents. Here some of the power of the plate circuit is brought back to the grid circuit for the purpose of exciting it and sustaining the oscillations. Now if the back-coupling between plate and grid is less than a certain critical amount, the audion will not oscillate, but nevertheless the energy feed-back into the grid circuit is manifested by an amplification effect in that circuit. One way of looking at this is to follow the process through step by step, forgetting for the moment that the whole action takes place almost instantaneously. For concreteness suppose that the audion is connected across the tuned secondary circuit of a coupled receiver. The signals impressed upon its grid are amplified, and some of this ampli-

fied, or extra energy, is brought back to the grid circuit and being in phase, augments the signal voltage. It is then re-amplified, brought back to the grid, and so forth, the course of this vicious electrical circle being run until the steady state is arrived at. This is referred to as "regenerative" amplification, and the effect was discovered experimentally by Mr. E. H. Armstrong. In such circumstances the tuned grid circuit acts very much as if its resistance had been reduced; in fact, when the back-coupling is sufficient to cause the system to break into sustained oscillations, the resistance is sometimes referred to as being zero. But this view should be applied with caution, and in any case must not be used as an argument against the importance of reducing the resistances of the coils and condensers to which the grid of the audion is connected. For in spite of the artificial reduction of the circuit resistance by the regenerative action, the signal response still remains inversely proportional to the actual circuit resistance and the amount of amplification which the regeneration yields will be governed by this resistance\* (see Fig. 117).

A number of methods of feed-back have been employed, and many of these have already been described in Art. 40 in connection with the generation of radio frequency power by means of the audion. The most satisfactory and popular forms for receiving purposes are the "tickler" coil circuit (Fig. 69 (a)) and the Armstrong tuned-plate circuit (Fig. 72). The following discussion will be devoted to these important circuits.

\* This fact was established experimentally by my former colleague, W. G. Ellis, radio expert of the U. S. Navy, to whom I am indebted for the use of the curves of Fig. 117.

(a) **Tickler Coil Circuit.**—The connections for this method of feed-back are illustrated in Fig. 115 in relation to the double-circuit tuner, Fig. 111. If the single-circuit tuner is used, the audion is connected across  $L_0$  as usual and the tickler coil is inductively coupled to it. The function of the condenser in the plate circuit is to pass the r.f. currents around the telephones and "B" battery. The regenerative action depends upon the wavelength, tickler coupling, ratio of  $L$  to  $C$  in the tuned grid circuit, and the effective resistance

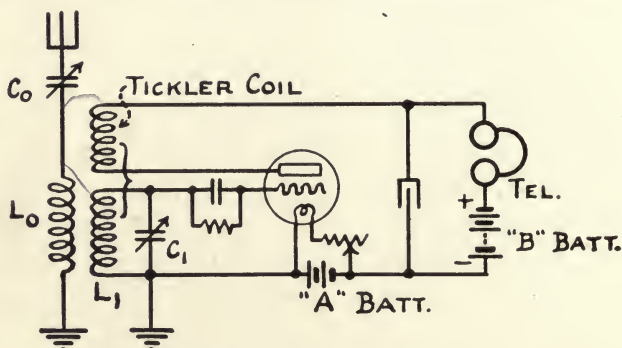

Fig. 115.—Schematic diagram of the tickler coil method of regenerative amplification.

of this circuit. It is controlled by the tickler coupling, which is made variable for this purpose, and is increased by increasing this coupling, decreasing the ratio of  $C$  to  $L$  in the grid circuit, and decreasing the resistance of this circuit.

For a wavelength range of 150–600 meters, about 20 or 30 turns of No. 26 d.c.c. wire on a tube 3" in diameter will make a proper tickler coil for use in conjunction with the tuners previously described. The resistance of this coil is of slight moment and special precautions need not be taken (as in the case of the tuned-circuit coils) to keep it low.

It is of some importance which terminal of the tickler coil is connected to the plate and which to the "B" battery; but the proper connections can be determined experimentally after the apparatus has been assembled. If oscillations or regenerative action are not obtained at the first trial, reverse the connections to this coil, or reverse the coupling between it and the secondary or antenna coil.

In operating this circuit the reader will note that, starting with a tickler coupling of zero, as this coupling is increased the strength of the signal will increase until a certain critical point is reached beyond which the circuit breaks into oscillation, a state whose existence can be detected by touching the grid terminal of the audion with the finger. If oscillations are present this will quench them and a dull thud or click will be heard in the telephone receivers. If "spark" signals are being received their tonal characteristics will probably be obliterated before this critical coupling is reached, due to the overlapping of their wave trains and the fortuitous character of the spark discharge as a radio frequency time event. Their musical sounds will then be supplanted by a rough note resembling escaping steam, and generally the strength of this signal will be very much greater than the strength obtained when the musical note is preserved. Radio telephone signals will generally be lost after passing into oscillation, but not necessarily. The reception of c.w. signals by this method will be considered in the next article.

I have been accustomed to represent this action graphically for the instruction of Navy radio operators by a diagram shown in Fig. 116. Here the distance from the dotted circle, or the depth of the shaded portion, represents

crudely the change in the intensity of the signals as the tickler coupling is increased from zero. The regenerative region is regarded as extending from zero to the point at which oscillation starts.

The effect of the tickler coupling upon the intensity of the signals is also shown graphically in Fig. 117. The ordinates (vertical distances) represent the telephone (sound) energy, and the abscissæ (horizontal distances) represent the tickler coupling. The amount of amplification obtainable

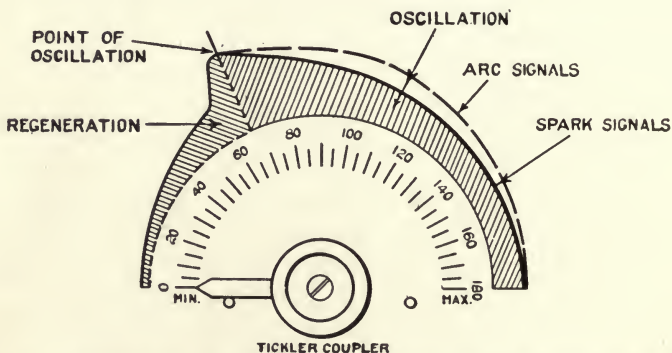

Fig. 116.—Representing change in signal intensity with variation of the tickler coil coupling.

by this method is indicated; in the case of no inserted resistance ( $R=0$ , the normal receiving circuit) this amounts to a magnification (energy) of about 26 times. Since a magnification of this amount would be produced by a well designed one- or two-stage radio frequency cascade amplifier; the substantial economy of the regenerative method is thus demonstrated. The fact that the tickler coupling, or rather the feed-back of energy from the plate circuit, does not compensate for the actual resistance of the grid circuit, at least so far as the signal response is concerned, and that

this circuit should be well designed, is also shown by the several curves, representing the effects of various inserted resistances in the tuned grid circuit.

For reasons which will be brought out in part in the course of the discussion of the Armstrong tuned-plate circuit, the tickler coil method is regarded as the most satisfactory method of regenerative amplification: A receiver

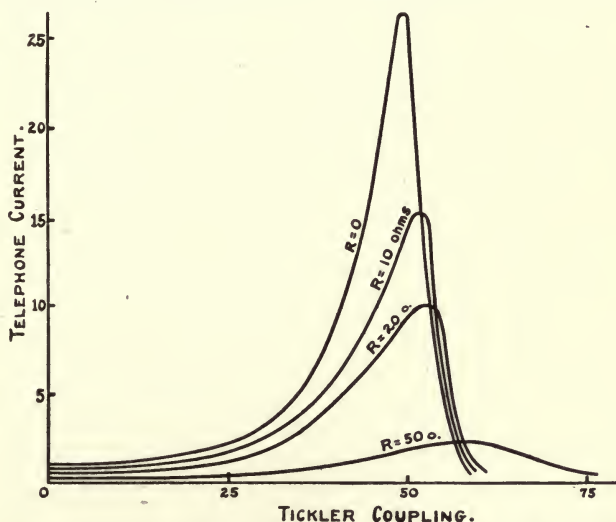

Fig. 117.—Graphical representation of the amplification due to the tickler coil method of regeneration, showing the effects of inserting resistance in the tuned grid circuit (Ellis).

compounded of the double-circuit or single-circuit tuner, and one audion bulb used with a tickler coil as shown in Fig. 115 will be very satisfactory for short distance work and as noted will give the same response as a good two-stage radio-frequency amplifier with detector, operating in the usual manner. But it will, of course, be harder to adjust and to operate than such a receiver.

(b) **Armstrong Tuned-plate Circuit.**—The connections of this method of regeneration are illustrated in Fig. 118 in relation to the double-circuit tuner of Fig. 111. The corresponding connections for the single-circuit tuner will be obvious to the reader and need not be indicated. As explained in Art. 40, the feed-back in this case takes place through the small condenser formed by the grid and plate electrodes of the audion and is induced by the insertion in the plate cir-

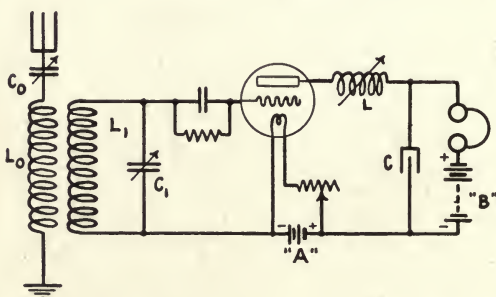

Fig. 118.—Schematic diagram of the Armstrong tuned-plate method of regenerative amplification.

cuit, of the inductance  $L$ . This inductance is made variable for the purpose of controlling the regeneration and usually takes the form of a variometer. A variometer having a wavelength range (with its inherent capacity) of 150–500 meters will be suitable for this purpose.\*

\* The inductance required for regeneration is given approximately by the formula:

$$L = \frac{1}{\omega^2 (C_m + C + \frac{C_m}{\mu})}$$

wherein  $\omega = 2\pi n$  ( $n$  = frequency);  $C$  = total capacity across  $L$  including the plate-filament capacity of the audion and the self-capacity of the variometer;  $C_m$  = grid-plate capacity of the audion;  $\mu$  = amplification factor of the audion. Inductance  $L$  and capacity  $C$  are expressed in henries and farads respectively.



As in the case of the tickler coil circuit the regenerative action is manifested by a decrease in the resistance of the tuned ( $L_1C_1$ ) grid circuit. The audion with its inductive

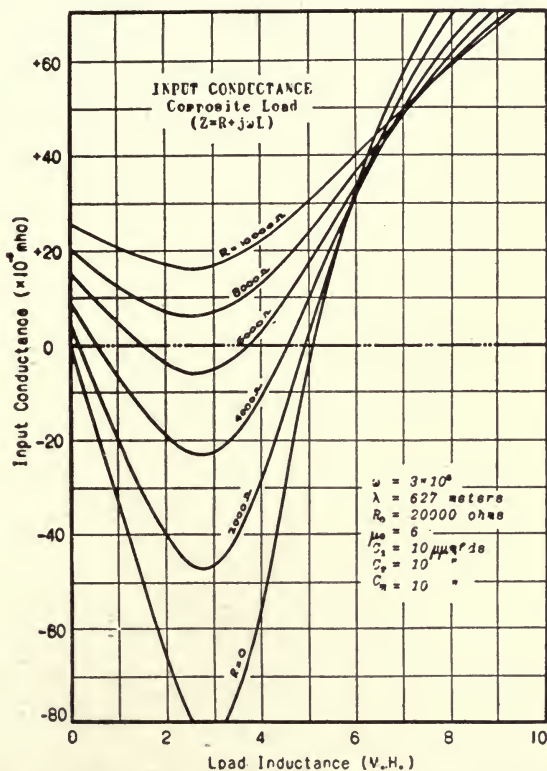

Fig. 119.—Curves showing the relation between the effective input conductance of an audion and the inductance in its plate circuit, for a typical case (W. E. "J" tube at 627 meters).

plate circuit may therefore be looked upon as supplying a negative resistance which counteracts to some extent the actual (positive) resistance of the grid circuit. The amount of negative resistance so introduced will depend,

of course, upon the amount of inductance in the plate circuit. The relation between the two is clearly illustrated in Fig. 119, which is reproduced from my *Physical Review* paper previously referred to (Art. 40), and is based upon computations from the theory of a typical case.

The ordinates of these curves are marked "Input Conductance" and are intended to represent the effective values of the conductance added across the tuning condenser  $C_1$  by connecting the audion to it. As the reader will observe, this is negative for a range of inductance values and represents regeneration throughout this range. The maximum regenerative effect is obtained in approximately the middle of the range. The signal strength may be taken as proportional to the input conductance, and this will furnish an idea of how the regenerative adjustment amplifies the signal. The several curves represent the effects of various inserted resistances in the plate circuit, and justify a previous statement to the effect that rather large losses may be tolerated in the plate variometer. The introduction of 100 ohms, for example, would have an almost negligible effect. Thus the plate variometer may be made very much smaller than the average commercial form and can be wound with fine wire, *e. g.*, No. 30 B. & S., or contain an iron core, without appreciably affecting the regenerative action.

Now in addition to its action in reducing the resistance of the tuned grid circuit, the audion with an inductive plate circuit also increases the capacity of this circuit, that is to say, it acts like a condenser as well as a conductance. Figure 120 shows the effective capacity of the audion as a function of the plate circuit inductance, in these circum-

stances. The ordinates represent the capacity; the abscissæ, the plate inductance. I would like the reader to notice that this capacity is in parallel with that of the tuning condenser (see Fig. 118), and its variations will affect the tuning of this circuit. It is unfortunate that the audion

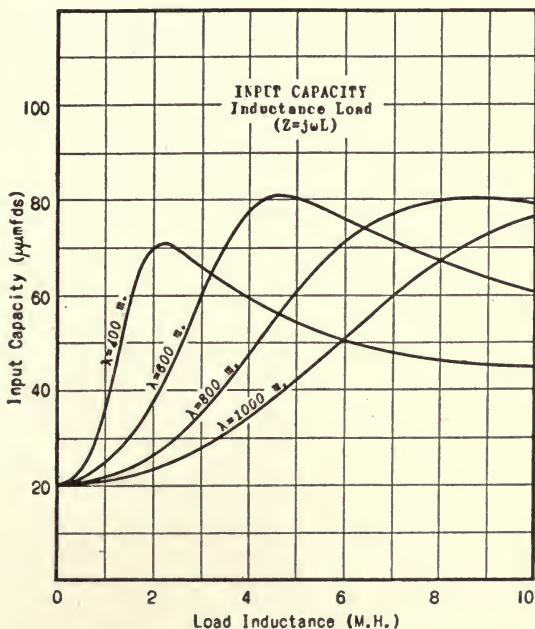

Fig. 120.—Curves showing how the effective (input) grid-filament capacity of an audion is affected by an inductance in its plate circuit (W. E. "J" tube).

capacity changes most rapidly with the inductance values most favorable to regeneration (compare Fig. 119, curve for  $R = 0$  (627 meters), and Fig. 120, curve for 600 meters). This is objectionable in that the adjustments for tuning and regeneration are not completely independent, and the inconvenience of this is aggravated by using a

tuning system (such as a variometer for tuning the secondary circuit of the coupled circuit tuner instead of a variable condenser), in which the tuning capacity is small. This is one reason for the expressed preference for the tickler coil arrangement; there the adjustments of tuning and regeneration are independent because the amount of inductance included in the plate circuit (the tickler coil) remains constant.

**74. Principle of the Heterodyne Method of Reception.**—The heterodyne method of reception and detection is used in connection with the unmodulated or sustained radio frequency waves employed in c.w. telegraphy. In commercial work these waves are supplied by a high frequency alternator; in amateur work, by an audion power oscillator. Its basic principle is easily apprehended and may be explained as follows:

For concreteness, suppose that a radio frequency wave of constant amplitude is incident upon the receiving antenna, and produces in the tuned circuits currents of the same nature. The presence of these currents will not be detected by an audion (or crystal) detector operated in the usual manner, for the wave simply produces in the plate circuit an elevation of the average plate current for its duration. The radio frequency vibrations of the plate current are not considered, because, as has already been explained, they are incapable of affecting the telephone receivers, or of being heard if they did succeed in affecting them. The presence of this signal is made known to us in the heterodyne method by adding to it another radio frequency wave of constant amplitude but of slightly different frequency. The combination of the two waves results in a wave of

frequency equal to the mean of the two frequencies, but with an amplitude which varies at a frequency equal to one-half the difference of the frequencies. This is known as the phenomenon of "beats" and is illustrated in Fig. 121.

In the practical application of this principle the extra radio frequency current is generated at the receiving station and its frequency is adjusted there until the beat note has

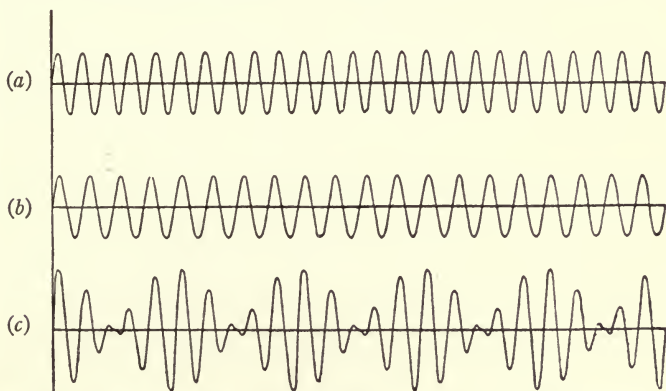

Fig. 121.—Illustrating the formation of "beats" (c) by the addition of waves (a) and (b) of slightly different frequencies.

the desired frequency within the audible range. Thus the whole process simply consists in artificially producing a modulation of the incoming signal. It is then detected as any other modulated signal, a radio telephone signal for example, would be detected. According to whether the local oscillation is produced by a separate audion oscillator or occurs in the receiver circuit itself, the reception method is referred to as the *separate-heterodyne* or *self-heterodyne* (*autodyne*) method. For brevity the former method is

often called simply the *heterodyne* method, the latter the *autodyne* method.

One of the most valuable features of this method of detection is the large amplification that is obtainable simply by increasing the strength of the local oscillation. It is found experimentally that in both the heterodyne and autodyne systems the telephone response for signals of

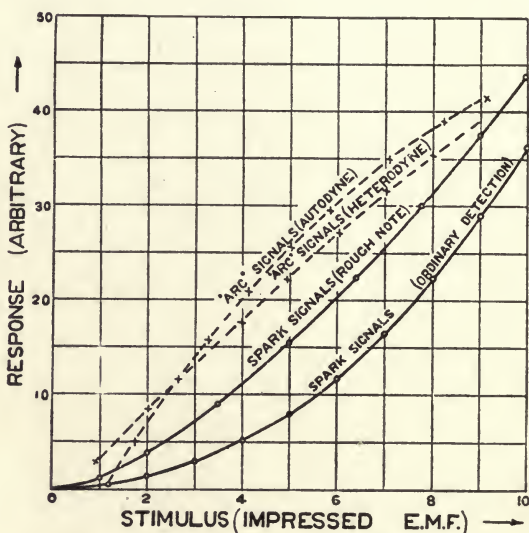

Fig. 122.—Showing the relation between the telephone response and the signal voltage, for various methods of signalling and reception.

moderate strength, is roughly proportional to the product of the signal strength and the strength of the local oscillation. This is in contrast to the detection of “spark” or other modulated signals (radio telephone signals) where the response is proportional to the square of the signal strength. The relation as determined experimentally is shown in Fig. 122, the ordinates representing the telephone response

and the abscissæ the signal voltage (stimulus).\* The linear relation between signal voltage and response, characteristic of the heterodyne and autodyne methods, compared with the second power curve of the ordinary detection, indicates that by this means the feeble signals are amplified just as much as the strong ones, whereas in the latter method the weak ones lose in detection while the strong ones gain. Thus in c.w. signalling the signal strength goes down inversely as the distance from the transmitting station, and in spark or i.c.w. telegraphy or radio telephony the response decreases inversely as the square of the distance. The inherent superiority of the c.w. method of telegraphic communication is therefore manifest.

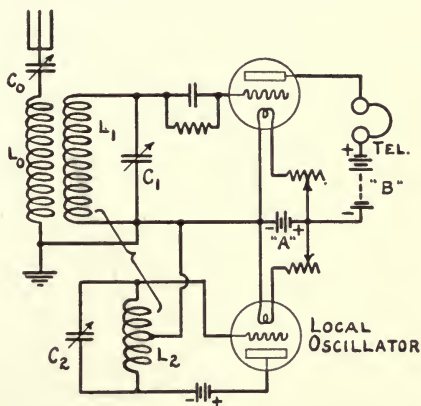

Fig. 123.—Connections of a simple receiver for c.w. signals using the heterodyne method with separate oscillator.

### 75. Receiving Circuits Applying the Heterodyne Method.

—The term *heterodyne* is used here to mean the *separate-heterodyne* method in which the local oscillation is furnished by an extra oscillator. This oscillator consists simply of a small receiving audion, connected to a suitable oscillating circuit, and so arranged that the frequency of the generated oscillations can be readily controlled by the operator. A very reliable circuit for this oscillator is the Hartley

\* This illustration is reproduced from my article, "The Radio Compass," published in the *Year Book of Wireless Telegraphy and Telephony*, London, 1921.

circuit illustrated in Fig. 70, and Fig. 123 shows the connections for the complete heterodyne receiver, in which an oscillator of this type is used. Here the receiver consists of a coupled-circuit tuner and ordinary audion detector. It will be understood that several stages of audio frequency amplification may be added. If radio frequency amplification is to be used the local oscillator should be coupled to the grid of the detector audion or to the plate circuit of the last radio frequency amplifier audion, and not to the secondary of the tuner as shown above. The coil  $L_2$  (100 microhenries) is an ordinary receiving circuit coil (for example, 30 turns of No. 18 d.c.c. wire on a tube 4" diameter), tapped approximately in the middle. The frequency of the oscillations is adjusted by means of the variable condenser  $C_2$  (max. cap. = .001 mfd.). The range of the oscillator is from 150 to 600 meters. If it should be found that the local oscillations are too strong, the oscillator may be set at a wavelength equal to 2, 3, 4, etc., times the wavelength of the received signal instead of approximately at this wavelength; then the feebler 1st, 2d, 3d, etc., harmonics can be used to produce the beat note. The adjustments of both the strength of the local oscillations and the frequency of the beat note are more easily made when the harmonics are used.

The heterodyne receiver is rather hard to operate, for in picking-up signals the tuner and oscillator must be manipulated together, keeping their wavelengths approximately equal while exploring the wavelength scale. Its main advantage is that once the adjustment is made the frequency of the beat note is not affected by small capacity variations due to a swinging antenna or to the movements



of the operator's hand or body. It is assumed, of course, that the local oscillator employs a large tuning condenser and is either placed out of the operator's way or well shielded from his electrical influence.

#### 76. Receiving Circuits Applying the Autodyne Method.—

The autodyne or self-heterodyne method requires no special apparatus, a regenerative circuit being used and the feedback coupling adjusted until oscillations are obtained. The frequency of the oscillations corresponds to the wavelength adjustment of the circuit, so that by slightly detuning the receiver the wavelengths of the signal and local oscillation may be made sufficiently different to give the desired beat note. The amount of detuning required is not large at short wavelengths and the signal strength is but slightly diminished by the maladjustment.

The theory of the autodyne audion receiving c.w. signals is very complicated and not generally well understood. The merit of the system, or the strength of the telephone response for a given signal strength, depends upon the instability of the oscillations in the circuit. Specifically, with the tickler coil arrangement, the sensitivity is closely proportional to the rate at which the average plate current changes with a slight change in the tickler coupling.\* This will depend to a large extent upon the stability of the oscillating state, and as a general rule we may say that anything that can be done to make the oscillations less stable will increase the intensity of the beat note. For this reason the tickler coupling should not be increased much above the

\* This and other statements of this section rest upon an experimental study of the heterodyne and autodyne methods of reception which the writer made for the Navy in 1918.

point at which oscillations start. I have also found the use of a grid biasing voltage preferable to a grid condenser and resistance for promoting instability, and the bias should be made adjustable so that the greatest change in plate current for a given change in tickler coupling can be obtained. The tickler coil circuit is more suitable for this work than the tuned-plate circuit, and connections for a complete receiver

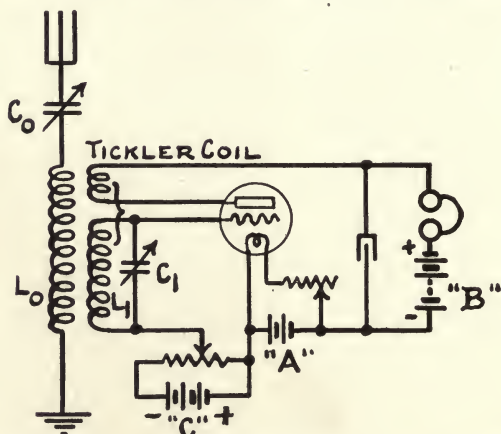

Fig. 124.—Connections of a simple receiver for c.w. signals using the heterodyne method with self-oscillation.

embodying this circuit and including an adjustable grid bias are given in Fig. 124.

The operation of the autodyne circuit is much simpler than that of the heterodyne; in picking up signals it is simply necessary to run over the gamut of wavelengths, adjusting the regeneration at the same time to maintain the circuit in the oscillating state. In the next article a special receiver will be described in which even this latter adjustment is eliminated, the oscillating state being automatically maintained during the adjustment of the tuning.

The main disadvantage of the method resides in the effect of the circuit constants upon the wavelength of the local oscillation, whereby small capacity changes produced by a swaying antenna or by the hand of the operator cause troublesome changes in the frequency of the beat note. It is desirable for this reason (and also to reduce the radiation of undamped waves from the receiving antenna which may interfere with other receiving stations) to use a double-circuit tuner and to properly shield all parts of the circuit likely to be within the electrical influence of the operator. The use of the double-circuit tuner, of course, considerably complicates the operation and makes it very difficult to pick-up signals; nevertheless in the hands of a patient and expert operator it has many advantages.

**77. The Reinartz Tuner.**—This receiver, devised by Mr. J. L. Reinartz, is, according to the testimonials of many amateurs who have used it, the most satisfactory apparatus for the reception of c.w. signals. It is simple, easily constructed and has the special advantages for c.w. work of having but one adjustment for the wavelength, and oscillating freely and with proper restraint over the entire wavelength range (130–400 meters). The latter feature is especially convenient in picking up c.w. stations, and is attained by a modification of the Chambers feed-back circuit and the combination of inductive and capacitative feed-back first exploited and put into practical apparatus by Messrs. Jones and Priess, formerly engineers of the U. S. Navy. The following description of the Reinartz receiver is abstracted from articles appearing in the June, 1921 and March, 1922 issues of "QST," which the reader is urged to consult for a more detailed account.

A schematic diagram of the connections is shown in Fig. 125. The coils  $L_1$  and  $L_2$  are wound with No. 26 s.c.c. copper wire in spider-web fashion on nine "spokes" around a  $2\frac{1}{2}$ -inch center, the completed coil being about 5 inches in diameter (see Fig. 126). The plate coil comprises the first 45 turns; the wire is then cut and another coil of 40 turns is wound on the same form and in the same direction. Taps

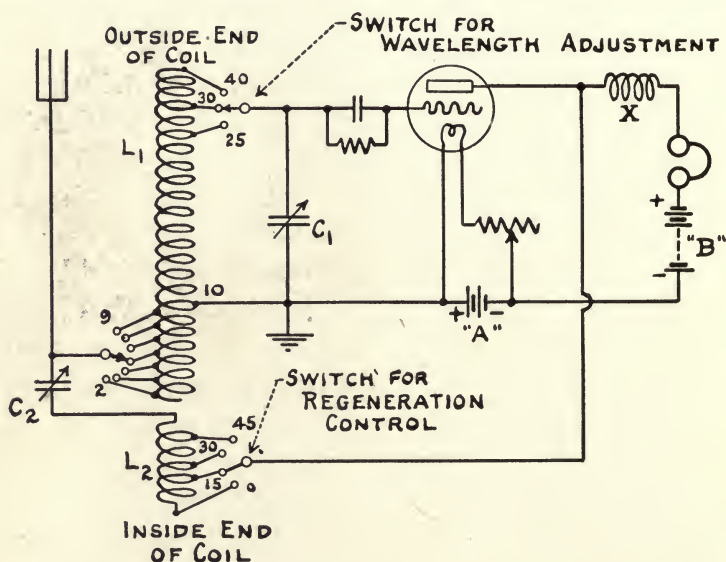

Fig. 125.—Connections of the Reinartz receiver for c.w. signals.

are brought out to the switches as follows: for the plate winding, at 15, 30 and 45 turns; and upon starting the second coil at 2, 4, 5, 6, 7, 8, 9 turns, with a ground tap at the 10th turn; and continuing the winding, at the 25th, 30th and 40th (outside) turns. The connections of the taps to the switches are clearly shown in the circuit diagram; also the functions of the switches are marked.

The condenser  $C_2$  (23 plates; max. cap. about .0005 mfd.) controls the feed-back and the condenser  $C_1$  (13 plates; max. cap. about .0003 mfd.) is used for tuning. For minimization of the capacity effects of the operator's body the rotary plates of the condenser  $C_2$  should be connected to the antenna, those of  $C_1$  to the earth. The function of the r.f. choke-coil  $X$  is to prevent the short-circuiting of the radio frequency output circuit of the tube by the telephones (or primary of an audio frequency amplifier transformer) and the "B" battery. This may be of the 3 m.h. type described in Art. 44 (*d*).

A good mechanical arrangement of the parts is shown in the exterior and interior views of the receiver, Figs. 127 and 128.

**78. The Armstrong Super-heterodyne Method for Reception at Short Wavelengths.**—The super-heterodyne method of reception is another product of the ingenuity of Mr. E. H. Armstrong and represents his solution of the important and difficult problem of amplifying signals of short wavelength. The performance of cascaded radio frequency amplifiers at the high frequencies represented by wavelengths of the order of 100–600 meters is considerably poorer than their performance at lower frequencies, due to actions which will be more fully considered in the

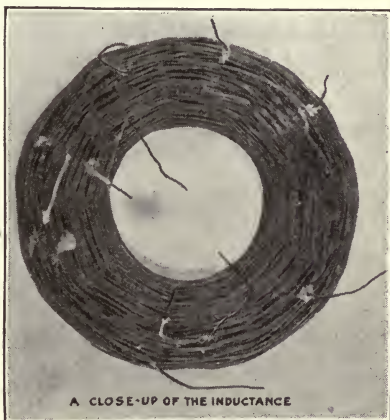
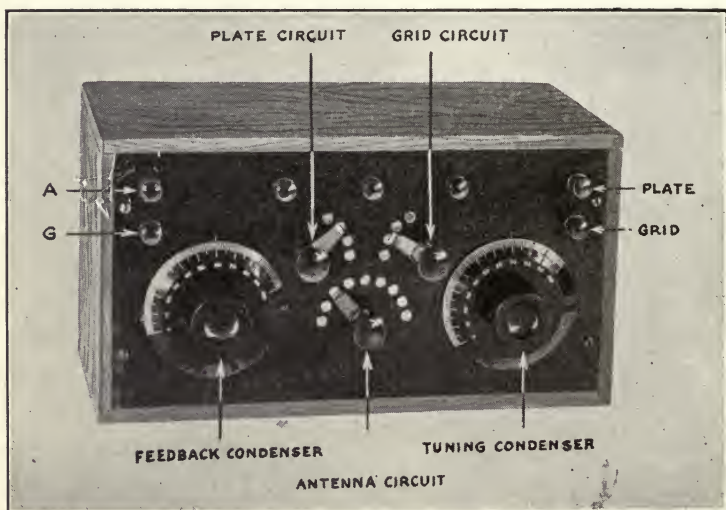
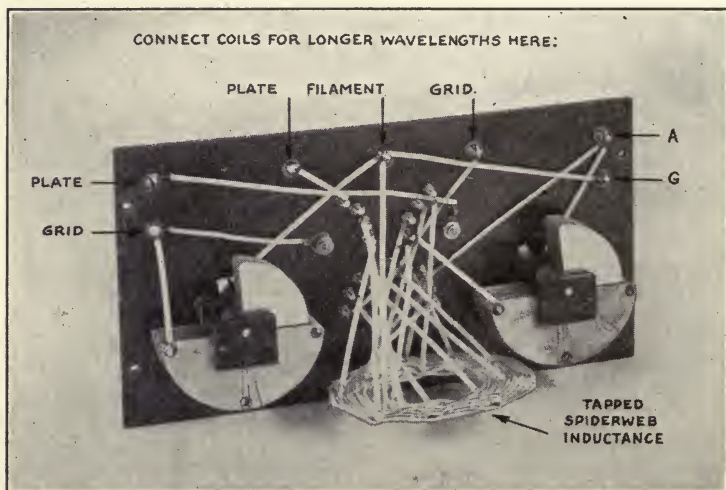

Fig. 126.—Illustrating "spider-web" coil of the Reinartz c.w. receiver.

## RADIO TELEPHONY



*Fig. 127.—External view of the complete receiver.*



*Fig. 128.—Showing arrangement of coils and condensers in Reinartz receiver.*

section on amplifiers. The method of the super-heterodyne consists in changing the natural high frequency of the signal to a lower frequency more suitable for amplification by the cascade process. The frequency change is produced without appreciable distortion and all the characteristics of the original signal are preserved. This is accomplished by an application of the heterodyne principle; by adding to the signal another oscillation whose frequency differs from that of the signal by an amount necessary to give a beat note of the lower *radio* frequency. This combination of currents is then rectified and yields an alternating current whose frequency is equal to the difference of the two frequencies.

This process has already been explained, and is nicely illustrated in Fig. 42. Suppose that the middle curve ( $E_g$ ) in this photograph represents the beats which have been formed as a result of the combination of the signal and local oscillation. The lower curve then represents the plate current of the detector; and if the plate circuit contains an *LC* branch tuned to the beat frequency, the higher frequency currents will be suppressed, leaving the beat frequency current shown in the upper trace. Thus the system acts simply as a frequency transformer; and the output is of the proper wavelength to be efficiently handled by a cascaded radio frequency amplifier of the usual type.

The electrical scheme is illustrated in Fig. 129. This shows a coupled circuit tuner and detector connected together in the normal fashion. The detector may be arranged for regenerative amplification; this is not shown, but a better response will be obtained by its use. The local oscillator is of the type previously described in connection

with the separate-heterodyne method. Autodyne, or self-heterodyne methods, are not convenient because to produce a beat note of say 50,000 cycles (6000 meters wavelength) with a signal of 300-meter length, the oscillator's wavelength must differ by 15 meters, and if the receiver furnished its own oscillation a detuning of this amount would appreciably diminish the signal voltage. The transformer  $T$  is tuned to the wavelength to which the signal has been changed. It is customary, I believe, to change to a wavelength of 6000 meters. This could be conveniently reduced

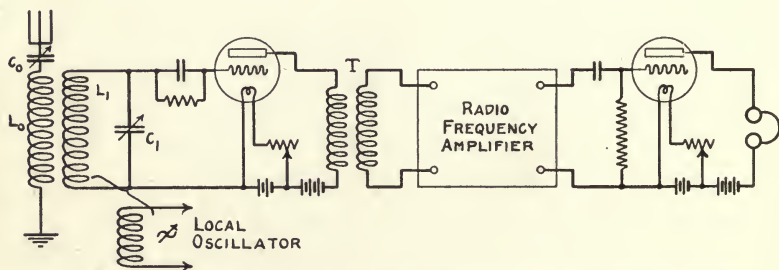

Fig. 129.—Schematic diagram of the Armstrong super-heterodyne receiver.

to 2000 or 3000 meters, thus permitting the efficient use of the choke-coil coupled amplifier to be described later. After amplification the radio frequency signal is detected in the usual way. The use of two detectors may confuse the reader, but it should be remembered that the first detector is used in the transformation of the frequency; the second detector is necessary, for the new frequency is still above audibility.

A complete system is illustrated in Fig. 130 and a sufficiently detailed description of the principal constants and parts is given to enable the reader to construct it. The



FIG. 130  
 COMPLETE DIAGRAM OF CONNECTIONS FOR ARMSTRONG SUPER-HETERODYNE  
 RECEIVER FOR 150-600 METER WAVELENGTHS

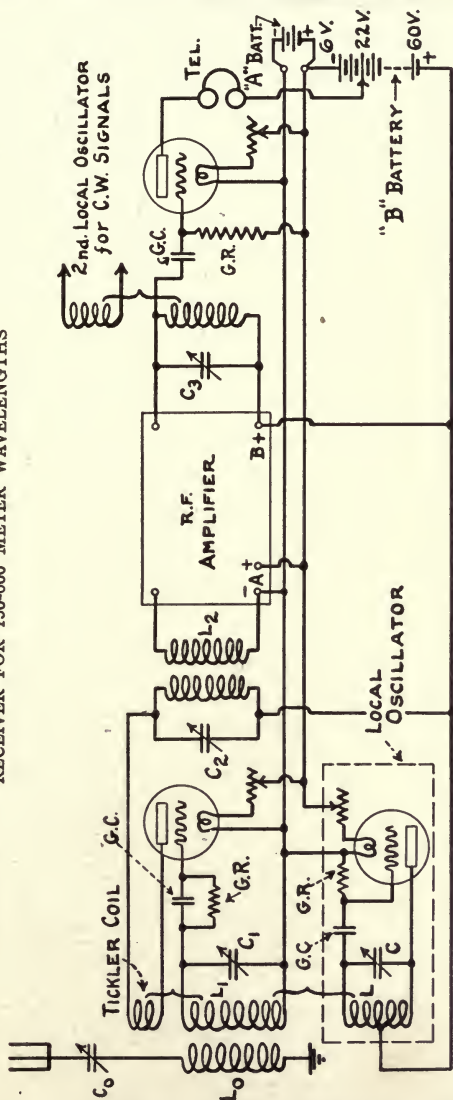

DESCRIPTION

- $L_0, C_0, L_1, C_1$ .....See Art. 71
- Tickler coil.....30 turns No. 26 d.c.c. 3" dia.
- $L_2, C_2$ .....See text
- $C_2, C_3$ .....Variable, max. cap. .0005 mfd.
- $L_3, C_3$ .....30 turns No. 18 d.c.c. 4" dia.
- $C_3$ .....Variable, max. cap., .001 mfd.
- G.C.....Grid condenser, cap., .0002 mfd.
- G.R.....Grid resistance,  $\frac{1}{2}$  to 2 megohms

separate heterodyne oscillator employs an ordinary receiving audion, and while enough power is available, rather close coupling between it and the secondary coil  $L_1$  is necessary to force the proper current through the high impedance which the tuned secondary circuit offers at the oscillator's frequency. For example, to change a signal of 300 meters wavelength to 3000 meters, the oscillator would be adjusted to 330 meters; a sharply tuned secondary circuit would offer a substantial impedance to a 330 meter oscillation. The oscillator employs the Hartley circuit and has already been described (Art. 75). The 3000 meter transformer  $L_2C_2$  may contain an iron core. The double winding is simply a convenience to eliminate the isolation condenser in the grid lead of the first amplifier audion, which would be indicated with a single winding in order to keep the plate voltage off the grid of this tube. These coils may be wound together in a multi-layer form of rectangular cross-section, with 250 turns apiece,  $3\frac{1}{2}$ " mean diameter; or they may consist of two 300-turn honeycomb coils, bound closely together with tape. The writer prefers the use of iron-cored coils at these wavelengths; a core of "radio-frequency-iron," built up of laminations of .002" (2 mils) thickness, approximately  $1\frac{1}{2}$ " x 3" inside, and  $\frac{3}{4}$ " cross-section, wound with 300 turns of No. 36 s.s.c. wire in a coil of diameter  $1\frac{3}{8}$ ", will be suitable. The same construction may be used for the output coil, but in this case but a single winding is necessary, for a grid condenser is used (for detection) in any case, and will serve to keep the plate voltage off the detector grid. If the coils are wound close together so that their coupling is close, but one tuning condenser will be necessary as shown in the diagram. The r.f. amplifier will be

described later. The detector arrangement is the usual one; and the signal may be amplified after detection by means of audio frequency amplifiers of the usual type. This amplifier is connected in place of the telephones.

In putting the circuit into operation the input transformer  $C_2L_2$  and the output transformer  $L_3C_3$  are first tuned to a convenient wavelength, let us say 3000 meters. This may be done with a wavemeter, or may be approximately adjusted in the ordinary course of operation by manipulating  $C_2$  and  $C_3$  until the signal has its maximum intensity. Subsequent adjustment of these circuits should not be made. There are three tuning adjustments: the antenna circuit, secondary circuit, and local oscillator; in addition, there is the tickler adjustment for regeneration. This multiplicity of adjustments makes the operation of the system rather tedious and difficult, and for that reason and also to avoid interference, many amateurs prefer to eliminate one adjustment by using a coil antenna. The coil is connected in place of the secondary coil  $L_1$  (Art. 38) and a small series inductor is included between it and the tuning condenser  $C_1$ , to which the tickler coil and local oscillator may be coupled. For the reception of c.w. signals the use of a second local oscillator is convenient. This need not have a wide range of wavelengths, in fact, once adjusted it requires no further attention since all signals may be transformed to the same wavelength and will then give the same beat note with the local oscillator. The wavelength of the local oscillator should, of course, be in the neighborhood of that to which the r.f. amplifier system is adjusted, and to which the signals are changed by the heterodyne process. One or two stages of r.f. amplification are usually necessary to compensate

## RADIO TELEPHONY

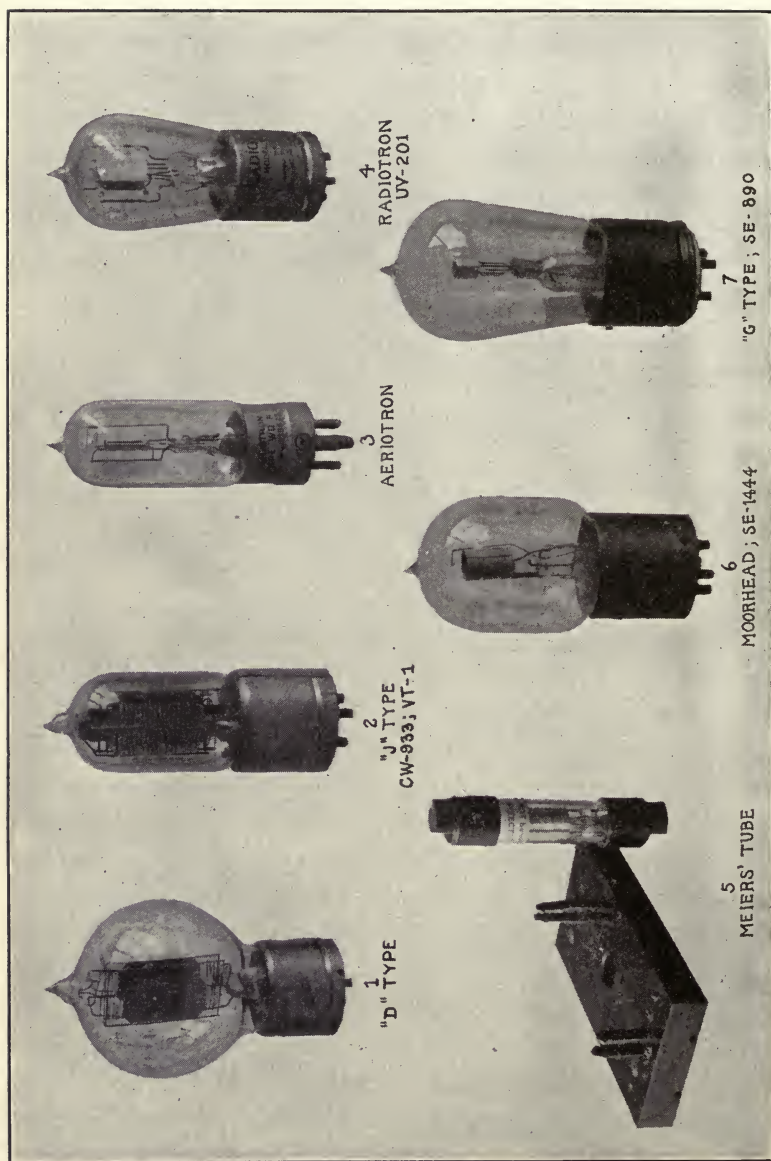

Fig. 131.—Illustrating some commercial types of audions for receiving purposes (amplifiers and detectors).

TABLE V  
ELECTRICAL CHARACTERISTICS OF SOME TYPES OF AUDIONS USED FOR RECEIVING PURPOSES

Type Designation.	1 "D"	2 "J"	3 Aerion. tron.	4 Radio- tron UV-201	5 Meters	5 Moor- head.	7 "G"	Radio- tron UV-200
Manufactured by .....	W. E.	W. E.	West- inghouse	R. C. A.	R. A. Co.	M. L.	G. E.	R. C. A.
Filament .....	coated	coated	coated	tungsten	tungsten	tungsten	tungsten	tungsten
Filament current (normal) .....	1.1 a.	1.2 a.	0.2 a.	1.0 a.	0.8 a.	0.8 a.	0.7 a.	1.0 a.
Filament voltage (normal) .....	2.3 v.	2.6 v.	1.1 v.	5.2 v.	3.3 v.	5.2 v.	2.3 v.	5.2 v.
Amplification factor .....	40	6.5	6	7.5	5	9	9	erratic
Plate resistance (ohms) .....	70,000	18,000	20,000	18,000	15,000	32,000	45,000	erratic
Mutual conductance ( $\mu$ mhos) .....	570	360	300	410	320	280	200	erratic
Plate voltage for amplification .....	150 v.	60 v.	30 v.	60 v.	30 v.	60 v.	60 v.	20 v.
Plate voltage for detection .....	20 v.	20 v.	10 v.	.....	10 v.	30 v.	30 v.	20 v.
Grid bias (volts) .....	-1 v.	-1 v.	-1 v.	-1 v.	-1 v.	+ 2v.	-1.5 v.	no data
Grid-plate capacity (mfd.) .....	10	11	4	6	3	5	5	no data
Plate-plate capacity (mfd.) .....	8	9	3.5	4.5	6	3.5	5	no data

W. E.—Western Electric Co.; R. C. A.—Radio Corporation of America; R. A. Co.—Radio Audion Co.; M. L.—Moorhead Laboratories; G. E.—General Electric Co.

for the unavoidable losses occurring in the wavelength changing process; stages in excess of this are pure gain.

This is a very remarkable system and one which yields amplification which cannot be attained with ordinary r.f. amplifiers operating at the natural signal wavelength (using the high-capacity tubes available for amateur use), with less than two or three times the number of stages. It was mainly through the use of this receiver that Mr. P. F. Godley was able to hear in Scotland many of the American amateur stations—some of them using but a few watts of transmitting power—during the recent trans-Atlantic tests conducted by the A.R.R.L. In making this statement there is no intention to discount the very important factor of expert operation.

**79. Electrical Characteristics of Audions Used as Detectors and Amplifiers.**—In the section treating of the application of the audion as a power generator, a compilation of the electrical and mechanical data and characteristics of the various commercial types of tubes was given. It is proposed here to furnish a similar collection of data for the tubes used for receiving purposes, as amplifiers and detectors. A rather wide variation exists in the mechanical construction and the electrical properties of commercial types of tubes, expressing the ideas and preferences of their designers, and adapting them for different applications.

Figure 131 illustrates some of the popular and familiar types of audions, of which many are available for amateur (experimental) use. The accompanying table gives the important electrical data of these, and another of which a photograph was not available. This data rests almost entirely upon tests made by the writer, or under his direc-

tion, so that full responsibility for their correctness will have to be assumed. While an effort has been made to record good average values, but a limited number of tubes were available for test and wide variations from these values may be expected with most types. The inclusion of the manufacturers' names is slightly irregular, but is justified by the common practice of referring to the audions by these names. The common designations of the praxis, and the type numbers assigned by the Navy and Army, are also given.

With regard to "amplification factor," "plate resistance" and "mutual conductance," these are technical terms defining certain electrical properties as follows:

The *amplification factor* is the ratio between the plate voltage and grid voltage for constant plate current.

The *plate resistance* is the rate at which the plate voltage changes with respect to the plate current.

The *mutual conductance* is the rate at which the plate current changes with the grid voltage.

These definitions are given in most text-books on the subject, to which the non-technical reader is referred for further information. The plate-grid and plate-filament capacities of the tube (not including the socket) have also been given; these are important in the design of radio frequency amplifiers.

All the tubes illustrated are of the so-called "hard" or high vacuum type. The *Radiotron*, *UV-200* and certain other types of which the data are not available, notably the so-called *Audiotron*, contain small quantities of gas, which gives to the tube a characteristic more suitable for detection

than that of the hard tubes. The use of gas, however, makes the device critical in adjustment and a careful regulation of the grid and plate voltages and the filament current is necessary in order to realize the substantial improvement thus afforded. These adjustments are conveniently made if the proper "potentiometer" connections are made to the batteries. It has not been sufficiently noticed that such tubes are also superior to hard tubes as amplifiers, although the range of operation is considerably smaller and sometimes hard to find. For this reason the gas-filled tubes have found no commercial application; this should not, however, deter the amateur from using them. One of the best audion detectors ever made was the old DeForest-McCandless bulb which flourished about 1914, and has unfortunately now become obsolete. These were made back in the days when an audion was called an audion, before the skill of operators had been dulled by two-stages of audio frequency amplification. Comparative tests made with 75 of these detectors, and several approved commercial types, showed an average increased *current* response of 10 times. This record is eclipsed, so far as I know, only by the gas-filled tubes developed by Prof. Chaffee of Harvard; two of which, according to tests made last winter, gave improvement factors of 12 and 16 respectively. From this experience I feel justified making an unqualified plea for the more general use, and on the part of the manufacturers for a better production, of gas-filled tubes for detection—and amplification as well. The noises developed in these tubes will, however, restrict the amplification use to radio frequency systems.

The best detector action of the hard tubes is usually



obtained at a lower plate voltage than would be used for amplification. In most cases this voltage is about 20.

Coated filament tubes should not be burned at a higher temperature than that corresponding to a bright red or orange color ( $1000^{\circ}$  C.); the tungsten filaments may be operated at a bright white color ( $2300^{\circ}$  C.).

The electrical characteristics of an audion depend upon the size of the electrodes and upon the plate and grid voltages of operation. They are not affected, for a filament of constant length and structure, by varying the size of the electrodes provided the geometrical configuration remains similar to itself and all voltages are changed to correspond. Thus it is possible to build very small tubes having the same characteristics as the larger ones. This fact has been utilized in the design of the so-called "peanut" or liliputian tubes recently placed on the market by several manufacturers, and which are very economical in their current consumption from batteries. The "Aeriotron" (see 3, Fig. 131), the "N" tube of the W. E. Co., and the "Liliputformat" tube of the Germans, are examples of this practice.

**80. Amplification. Radio Frequency and Audio Frequency Methods.**—So far we have considered merely what may be regarded as the essential processes of reception, although certain simple methods of amplification have been described, notably the regenerative method for modulated signals (radio telephone, i.c.w., and "spark"), and the heterodyne method for c.w. signals. The Armstrong super-heterodyne cannot be regarded as a method of amplification; it is rather a method for changing the wavelength of the signal so that it can be more effectively amplified. The response with all these methods of reception may be

further improved by straightforward amplification, and the amplification may take place before the signal has been detected, after it has been detected, or both. Amplification of the radio frequency currents previous to detection is commonly referred to as *radio frequency amplification*, and amplification of the low frequency currents produced by the detector is called, for obvious reasons, *audio frequency amplification*. The scheme of these methods is shown in Fig. 132. An indicated, the r.f. amplifier is inserted between the tuning apparatus and the detector, and the audio frequency amplifier is inserted between the

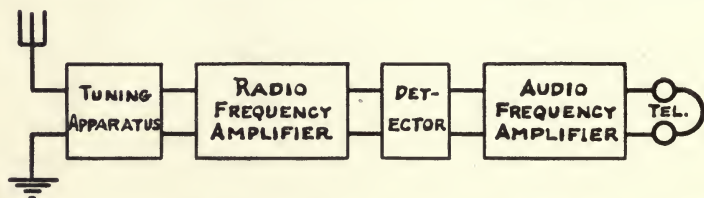

Fig. 132.—Illustrating symbolically the positions of the radio- and audio-frequency amplifiers in the receiving system.

detector and the telephones, loud-speaker or other electro-phonetic device.

Concerning the relative effectiveness of the two methods there is this to be said: Remembering that when radio telephone or spark signals are being received by the ordinary detection method, as Fig. 122 shows, the telephone current produced by the detector is closely proportional to the *square* of the voltage of the r.f. signal which acts upon it, it is clear that amplification previous to detection will be more effective than a similar amplification after it. Thus supposing that we have an amplifier capable of amplifying either the radio or audio frequency currents 10 times;

using it as a r.f. amplifier will give an increase of  $10^2 = 100$  times, whereas if it is used after detection the increase will be only 10 times. Hence if r.f. and audio frequency amplifiers can be built with equal effectiveness the first method is inherently superior to the second—solely on account of the peculiarities of the detector. With heterodyne reception of c.w. signals this does not apply, for in this case the response varies as the first power of the signal voltage and the two methods are, at least from this point of view, equally effective. But there are other considerations which modify these conclusions somewhat.

In the first place r.f. amplifiers cannot be built, particularly for the short wavelengths used by amateurs, to function as well as those designed for audio frequencies. This would seem to favor the audio frequency system. But the audio frequency system also has its drawbacks. Because it does amplify the low frequencies, it amplifies not only the signal but all those extraneous and parasitic variations of current which are the unavoidable accompaniment of mechanical vibrations of the audion bulbs, and of irregularities in the electrochemical action in the batteries. The magnification of these tube and battery noises, and other disturbances of this nature, limits the number of audio frequency stages that can be comfortably employed to two, or possibly three.

Taking these practical matters into consideration, and looking at the problem from an economic angle, the best way to improve the response by amplification would be to first provide a two-stage audio frequency amplifier, then to add radio frequency stages according to the availability of the tubes and the constructive ability of the operator.

Of course a greater number of low frequency stages may be used if a loud-speaker or other sound amplifying device is to be operated, but this will generally increase the volume of sound without increasing the range of reception. This is not due, as many people believe, to the detector having a threshold stimulus characteristic whereby any signal of deficient strength is incapable of affecting it, but to the simultaneous magnification of the undesirable noises. So far as I am aware, there is no quantum theory of detector action to support the former idea. When the addition of r.f. stages is contemplated, it should be remembered that the regenerative method of amplification described in Art. 73 accomplishes as much with one audion as one or two stages of this type; hence this is the first step to be taken.

### 81. Concerning Cascaded Audion Amplifiers in General.

—Both the radio frequency and audio frequency amplifiers usually employed are of the cascaded type, so that a consideration of this general method will furnish a foundation for the subsequent separate treatment of the two applications. The cascaded system consists of a series of audion amplifiers arranged electrically so that the amplified output of each tube is passed on to the next, to be again amplified, passed on, and so forth. Each tube with its passing-on mechanism, or coupling, is referred to as a *stage* or *step* of the amplifier. Several methods of linking the tubes are employed; and the reference to the amplifier as of the *resistance-coupled*, *transformer-coupled* or *inductance-coupled* type is based upon the electrical nature of this link. The three important methods of coupling may be explained as follows:

(a) **Resistance Coupling.**—The method of employing a resistance for the purpose of passing the amplified output of the plate circuit of one tube on to the grid of the next is illustrated in Fig. 133. This shows a two-stage amplifier, in which a resistance  $R$  has been inserted in the plate circuit of the first tube. The variation of the plate current flowing through this resistance causes a variable voltage drop across it which is impressed upon the grid of the next tube. On account of the fact that the point to which the grid is connected is normally at the d.c. plate voltage, a special means of connecting the grid is employed so as to

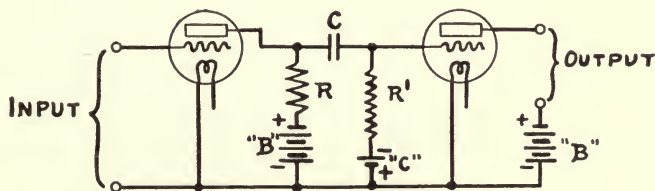

Fig. 133.—Scheme of resistance coupling in audion amplifiers.

avoid operating the grid at this unsuitable potential. As was pointed out in Art. 13, if the audion is to give its maximum amplification, the normal potential of the grid must be adjusted so that the proper part of the characteristic curve (see Fig. 34) is used. The grid is, therefore, isolated from the d.c. plate voltage by the condenser  $C$ , and the proper negative bias is obtained by means of the resistance  $R'$  which is either connected to a "C" (biasing battery) as shown, or to a suitable part of the circuit. Thus  $C$  and  $R'$  are not part of the coupling means, although they do affect the impedance of this means to some extent, especially at high frequencies.

Theoretically the resistance  $R$  should be as large as pos-

sible, for the amplification per stage is proportional to the ratio of this resistance to the total circuit resistance ( $R + \textit{plate resistance}$  of the audion). There are practical reasons, however, why this resistance cannot be illimitably increased. When this resistance is used the normal plate voltage is less than the "B" battery voltage by the  $IR$  drop across it caused by the passage of the normal plate current; hence in order to operate the audion at the rated plate voltage the voltage of the "B" battery must be increased by this amount. For example, suppose that we wish to use the "D" tube (1, Fig. 131) having an amplification factor of 40, a plate resistance of 70,000 ohms and requiring 150 v. for normal operation. A resistance of 100,000 ohms would give an amplification per stage of 23.5 (at low frequency), but allowing a normal plate current of 1 m.a. the "B" battery voltage would have to be increased to 250 volts to get 150 volts on the plate. The extra "B" battery requirements of this system constitutes one of its chief drawbacks.

Resistance-coupled amplifiers possess the important property of amplifying currents of all moderate frequencies to the same extent. This is of especial value for the audio frequency amplification of radio telephone signals, for in order that these may be amplified without distortion it is important that the entire range of speech frequencies from 100 to 5000 cycles undergoes uniform magnification.

(b) **Inductance Coupling.**—This method is illustrated schematically in Fig. 134. The inductance, or choke-coil  $L$ , replaces the resistance of the preceding method, and the grid of the next tube receives its stimulus from the voltage drop across this impedance. The extent to which signals

are amplified by this method depends upon the proportion of the choke-coil reactance ( $= 2 \pi L \times \text{frequency}$ ) to the total circuit impedance; consequently the amplification decreases with the frequency, very slow current variations producing practically no e.m.f. across  $L$ . As applied in radio frequency amplifiers, the impedance of the choke-

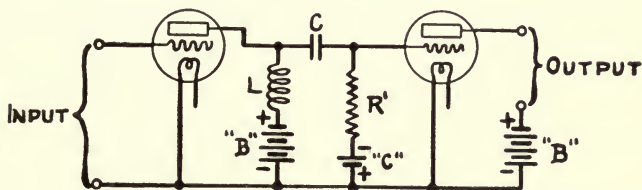

Fig. 134.—Scheme of inductance (choke-coil) coupling in audion amplifiers.

coil branch is often increased by connecting a condenser across it and tuning the branch circuit so formed to the wavelength of the signals to be amplified.

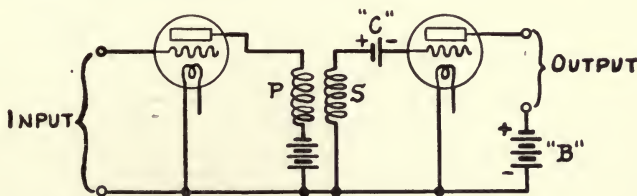

Fig. 135.—Scheme of transformer coupling in audion amplifiers.

In both the resistance and choke-coil methods of coupling the highest amplification per stage that can be attained is numerically equal to the amplification factor of the audion.

(c) **Transformer Coupling.**—In this case the grid of the second tube is inductively coupled to the plate circuit of the first tube as shown schematically in Fig. 135. The transformer  $PS$  is usually designed to operate at resonance,

and at low frequencies it is possible to use more turns on the secondary than on the primary, thus giving a stepping-up of the voltage. This aids the amplification and in these circumstances the amplification per stage may exceed the amplification factor of the tube. Were it not for the resonance effects due to the capacity of the windings and audions and dielectric losses in the secondary circuit, the step-up ratio could be increased indefinitely and enormous amplification might be obtained. This follows from the fact that when the grid of the audion is biased negatively no grid current flows and the tube consumes no power in its operation.\*

The grid is not conductively connected to the plate circuit of the first tube, hence the use of the isolation condenser, and the grid resistance for securing the proper bias, is avoided. The correct bias is imparted by including the "C" battery in the secondary circuit as shown in the diagram, or connecting to a point of the circuit giving an equivalent voltage.

**82. Combination Regenerative and One-stage Radio Frequency Amplifier.**—The simplest, most economical and effective scheme of radio frequency amplification for the average amateur is one embodying both the regenerative and a single stage of straightforward amplification. This accomplishes with a single tuning adjustment and with one tube what would ordinarily require two *tuned* stages of the usual type to do. An experimental test of this system made by the writer in 1919 showed that the regenerative contribution is of about the same amount as the straight-

\* Provided that the load in its plate circuit is of such a nature to give no effective grid input conductance (see pp. 211-213). This condition practically obtains at audio frequencies with any plate load.



forward amplification. The fact that the adjustment of the plate inductance for maximum regeneration in the Armstrong tuned-plate circuit corresponds approximately under usual conditions to the adjustment for maximum impedance of the  $LC$  branch circuit formed by the plate inductance, and its distributed capacity and the capacity of the leads and audions, permits us to take advantage of both methods of amplification simultaneously with one adjustment. The complete connections of a receiver with this method of amplification are shown in Fig. 136, to which the following description applies.

The construction of the double-circuit tuner has already been described (Art. 71 (*b*)). A d.p.d.t. switch is added, by means of which the amplifier may be connected across the secondary condenser, thus using a double-circuit tuner, or across the antenna coil, using the single-circuit scheme. The latter arrangement will be preferable for pick-up work because there are then but two adjustments to be made. The tuned-plate circuit increases the selectivity of the single-circuit arrangement to a degree which for ordinary work will be found ample; but if the operator prefers, the additional selectivity of the double-circuit connection may be realized after the signals have been picked-up by simply throwing the switch and tuning the secondary condenser. The mechanical arrangement of this switch needs no description. It will be noted that this also opens the secondary circuit when in the single-circuit position to prevent its abstracting energy. It is recommended that the amplifier and tuning units be built in separate cabinets.

The use of a two-stage audio frequency amplifier is presumed and is indicated in the diagram. This will be

FIG. 136

ELECTRICAL CONNECTIONS OF RADIO RECEIVER EMPLOYING SINGLE- OR DOUBLE-CIRCUIT TUNER, COMBINATION REGENERATIVE AND 1-STAGE RADIO FREQUENCY AMPLIFIER, DETECTOR, AND 2-STAGE AUDIO FREQUENCY AMPLIFIER.

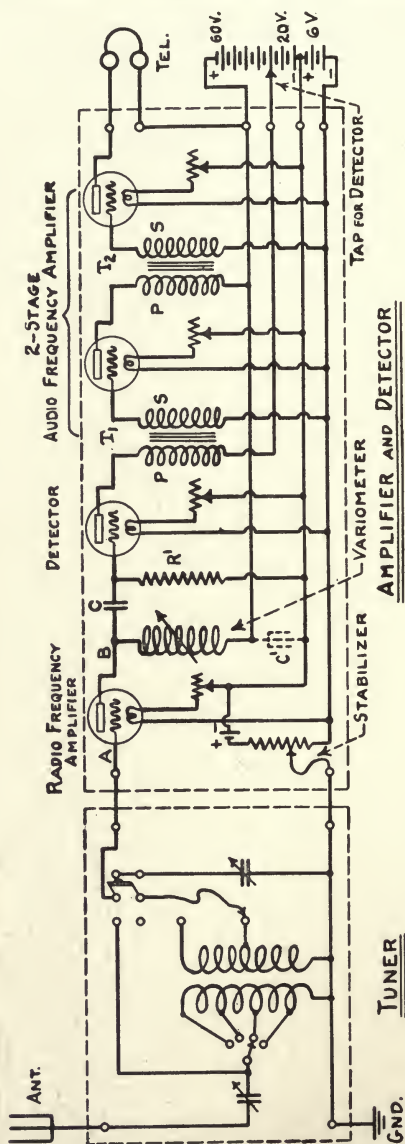

For detailed description see text.

described later (Art. 87). The radio frequency stage should be carefully wired. All filament leads are to be kept together and away from the plate and grid leads, and the leads marked "A" and "B," connected respectively to the grid and plate electrodes of the first tube, should be separated as far as possible. The lead "A" should be run direct to the grid and kept as short as possible. The object of this is to minimize the grid-plate capacity (upon which the regeneration depends) so that the regeneration and oscillation may be properly controlled. The stabilizer will assist in this control, and may consist of a 300-ohm "potentiometer" of the usual type connected across the "A" battery. The extra battery in this circuit may be necessary with certain types of tubes and wiring to get sufficient range of control. The plate circuit inductance is most conveniently a variometer having a natural wavelength range of 150-500 meters. Many suitable types are available on the market. There is no necessity for the variometer having low losses; resistances of 200 or 300 ohms can be tolerated in this circuit. It is sometimes helpful to connect between the variometer and filament lead a paper condenser  $C'$  of large capacity (1 mfd.) to diminish the feed-back from the detector and give more stable action. The grid condenser  $C$  is of the usual type with capacity .0002 mfd. The grid leak resistance  $R'$  ( $\frac{1}{2}$  to 2 megohms) may not be necessary with gas-filled detector tubes. The low voltage (20 v.) necessary for the detector is obtained by tapping in on the "B" battery as shown. The audio frequency amplifier will be described later.

In the assembly of the parts avoid close magnetic association of the variometer and the primary and secondary

coils of the tuner. If there is too much interaction between the units a proper shielding of both cabinets will be helpful (see Art. 86).

Regarding the selection of the tubes, preference should be given in the radio frequency stage to audions having a high amplification factor; the Meiers (both types) and Moorhead type have proved by general experience to be best suited for this purpose. Audions containing gas, as previously recommended, are preferable for the detector stage. For the audio frequency amplifier, the selection of the tube will be governed by the transformers available. Most commercial transformers will operate successfully with the type "J" Western Electric, Meiers' low "mu," or Radiotron, UV-201 tubes.

The writer considers this receiver to be most suitable for the average amateur, for the reception of radio telephone, i.c.w. and "spark" signals. It is not very convenient and less desirable than the Reinartz receiver (Art. 77) for c.w. work.

**83. Resistance-coupled Amplifiers for Audio and Radio Frequencies.**—Since the construction of resistance-coupled amplifiers for radio frequencies is substantially the same as that for audio frequencies, both systems may be treated under the same caption. As already pointed out, the most valuable property of this type of coupling is its ability to amplify all moderate frequencies to the same extent. This follows, of course, from the fact that the impedance of the coupling link through which the plate current flows and the voltage drop across which actuates the grid of the succeeding tube, is simply its resistance and is not affected by the frequency. For high frequencies corresponding to

the short wavelengths employed by amateurs, however, this statement demands modification for two reasons: First, across the resistance coupling two audions are connected so that it is shunted effectively by a capacity equal to the plate-filament capacity of the first tube plus the grid-filament capacity of the next tube, and at high frequencies the impedance of this capacity branch may be low enough to eclipse the effect of the resistance link. (For two tubes with plate-filament and grid-filament capacities of 9 mmfds., the impedance of the capacity path at 250 meters is only 7400 ohms.). Secondly, due to the grid-plate capacity of the second audion the resistance load in its plate circuit further increases the apparent capacity of this audion so that it adds not only its grid-filament capacity but this extra input capacity as well. In the case of the "J" tube with a 60,000 ohm resistance link in its plate circuit, at 200 meters, the effective impedance considering only the plate-filament and grid-filament capacities is 4800 ohms; assuming that this capacity could be made zero and considering only the effects of the feed-back action, the effective impedance of the coupling link is equal to 6000 ohms; but since both are present the actual impedance will be 4150 ohms. Thus an amplifier, compounded of "J" tubes, which at long wavelengths or for audio frequencies gives a voltage amplification of 4.5 per stage, would give at 200 meters an amplification of 1.02 per stage! In other words, the 2 per cent. amplification obtained at this wavelength would be completely negligible.

I have carried through this calculation to emphasize the effect of the audion capacities in diminishing the impedance of a resistance coupling link at short wavelengths, and to

emphasize particularly that the failure of this type of amplifier is not due solely to the plate-filament and grid-filament capacities, but is conditioned to about an equal extent by the feed-back action through the grid-plate capacity of the second tube, which we assume also has a resistance in its plate circuit. This contributory effect of the feed-back action has not been sufficiently noticed. This example will indicate the extreme importance of keeping these capacities small, using short leads, and small apparatus, grid condensers, leaks, etc. In selecting the tube preference should be given to those tubes having a high amplification factor, such as the W. E. Co.'s "D" type ( $\mu = 40$ ) and the Meiers' high "mu" tube ( $\mu = 20$ ). The latter is preferable for other reasons and is available for amateur use.

In view of the difficulty in obtaining audions with low inter-electrode capacities and the failure of the usual tubes over the range of wavelengths with which this book is mainly concerned (150-600 meters), I do not feel justified in devoting further space to this application or recommending it. Nor does the action improve to an expected extent as the wavelength increases, for although the impedance of the plate-filament and grid-filament capacities is no longer important, yet the capacity due to the feed-back action increases very rapidly with the wavelength. Consequently it may be concluded that the transformer and choke-coil methods of coupling are inherently more attractive, since in these cases the parasitic capacities may be turned to good use. This statement should not be construed to mean that resistance-coupled amplifiers will not work at wavelengths of 3000 meters, such as are utilized in the Armstrong super-heterodyne receiver; the point is

that choke-coil-coupled amplifiers will work better. If, however, the reader wishes to follow the general practice and use a resistance-coupled amplifier with the Armstrong system described in Art. 78 (Fig. 130) he may find the following description of a suitable amplifier of some interest.

(a) 3000-Meter Resistance-coupled Amplifier for Armstrong Super-heterodyne.—The connections of a 4-stage amplifier are given in Fig. 137. Four stages are indicated because this is the minimum number that should be used, and the maximum number that can be cascaded without the special

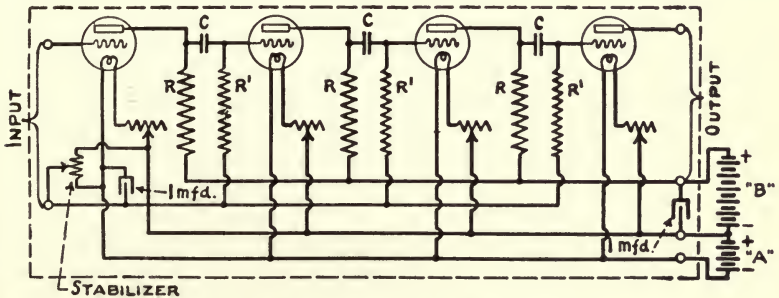

Fig. 137.—Electrical connections of 4-stage 3000-meter resistance-coupled amplifier for use with Armstrong super-heterodyne receiver, Fig. 130.

shielding and stabilizing precautions outlined in Art. 86. This discussion should be consulted if the addition of more tubes is contemplated. Because they do amplify all frequencies, resistance-coupled systems also magnify the low frequency tube and other extraneous noises to a considerable extent, hence the interposition of the tuned radio frequency  $LC$  circuit between the amplifier and detector is desirable to block these disturbances and to allow only the radio frequency currents to reach the detector. I am aware of the possible detecting action that may occur at

any stage of the amplification, especially in circumstances of incorrect bias and plate voltages and that by the use of an audio frequency filter this additional rectification is lost, but the first seems to be the greater evil. Anyone who has connected a 10-stage resistance-coupled amplifier directly to the detector will, I think, concur with this recommendation. I have found the use of a Type I ("high-pass") Campbell filter of value here, or what amounts to the same thing, the use of a choke-coil coupled stage (radio frequency) proximate to the detector. The  $L_3C_3$  circuit of Fig. 130 will be adequate, and a small ratio of  $L$  to  $C$  (using a *low resistance* coil) will aid the elimination of the low frequencies.

The coupling resistances  $R$  shown in Fig. 137 are of value 100,000 ohms and may be constructed in various ways. Sputtered film grid-leaks which have been reduced by reheating their filaments, carbonized cellulose films, non-polarizing electrolytic cells (these are sometimes very noisy), and various forms of carbon and graphite rods are useful, or a satisfactory resistance unit can be easily constructed by the amateur as follows:\* Coat a piece of bristol board 2 in. wide with a mixture consisting of 6 parts of Higgins' "American" India drawing ink and one part powdered graphite shaved from a grade H pencil. The mixture is applied to both sides of the bristol board strip with a camel's hair brush, stroking across the strip—not from end to end. After the strip has been thoroughly dried in a warm oven, cut a piece  $1\frac{1}{2}$  in. long from it and carefully wrap it around a glass tube  $\frac{1}{2}$  in. in diameter and 2 in.

\* This construction was described by Mr. P. F. Godley and is here reproduced together with Fig. 138 from *Wireless Age*, November, 1920, p. 13.



long, on the ends of which two strips of soft brass (covered with tinfoil) have been placed (see Fig. 138). The strip is now clamped in position with a second strip of soft brass (inserting a sheet of tinfoil between the brass and coated bristol board). The space between the clamps is then covered with two layers of cotton or silk tape, varnished with a clear, light, insulating varnish and again baked until dry. The inner and outer connection strips should be connected together. The resistances  $R'$  are

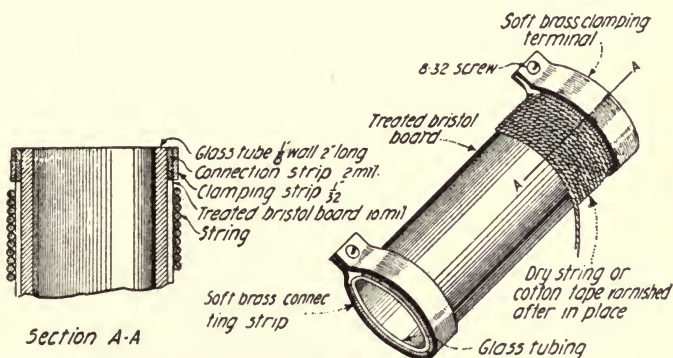

Fig. 138.—Illustrating construction of 100,000 ohm coupling resistance (Godley).

ordinary grid leak resistances of the order of 1-megohm. The condensers  $C$  may be paraffined paper condensers of capacity *not less than* .01 mfd. (The effective grid-filament capacity of the "D" and Meiers' high "mu" tubes at 3000 meters with a resistance in their plate circuits will be about .0001 mfd.). A suitable condenser of this capacity has already been described on p. 202 in connection with the single-circuit, crystal detector receiver. The "stabilizer" is useful for controlling the amplification and the tendency toward oscillation and may consist of the usual 300-ohm

“potentiometer.” The 1-mfd. condensers shown across the stabilizer and the “B” battery are necessary to reduce the radio frequency impedance common to the grid and plate circuits of the tubes. Other stabilizing precautions may be necessary (see Art. 86). In connecting this amplifier to the super-heterodyne receiver, Fig. 130, omit the direct connection from the coil  $L_2$  to —“A.” This coil is to be connected across the input terminals of the amplifier. The “B” battery voltages and amplification per stage corresponding to the use of several of the audions described in Art. 79 are given in the following table:

Type of Audion.	Amplification per Stage.	“B” Battery Voltage.
Meiers (high “mu”) . . . . .	4.6	110 v.
W. E. Co. “D” . . . . .	3.0	250 v.
Moorhead . . . . .	2.8	150 v.
Radiotron; UV-201 . . . . .	2.5	150 v.
W. E. Co. “J” . . . . .	1.5	110 v.

The low amplifications and high “B” battery voltages required by this system are rather discouraging.

(b) **2-Stage Audio Frequency Resistance-coupled Amplifier.**— On account of its ability to amplify currents of all moderate frequencies to the same extent, the resistance-coupled amplifier is very valuable for the amplification of the low frequency detected currents, especially in radio telephony where the entire range of from 100 to 5000 cycles is used and all frequencies within this range must receive the same amplification if there is to be no distortion. A suitable 2-stage amplifier for this purpose is shown in Fig. 139.

The coupling resistances  $R$  (100,000 ohms), the grid resistances  $R'$  (1 megohm) and the condensers  $C_1$  (.01 mfd.) are of the same construction as described for the 3000-meter amplifier. The condenser  $C_1$  connected across the resistance in the detector audion serves to shunt the radio frequency currents around this resistance and to keep them out of the amplifier. Because the detector requires a low plate voltage, the second audion contains a resistance in its plate circuit, and the third does not, three different

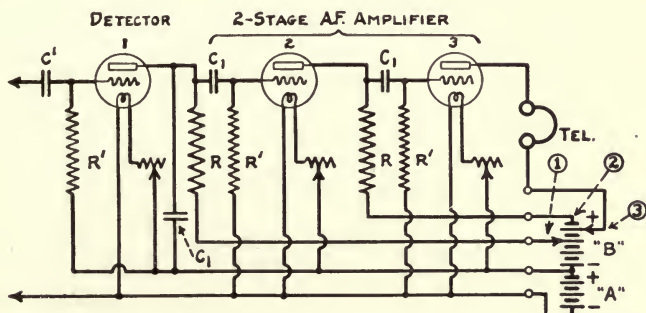

Fig. 139.—Electrical connections of 2-stage audio frequency resistance-coupled amplifier.

“B” battery voltages, obtained by the three taps (1), (2), (3) on the “B” battery as shown, will be required to give the proper plate voltages in each case. Presuming the use of a detector of the ordinary type operating on 20 volts, the “B” battery voltages of the three taps, and the amplification per stage that may be expected with several tubes used in the amplifier positions (2) and (3), are given in the table on page 254.

The great differences between the amplifications obtainable at these frequencies, and with the same arrangement at

Type of Audion.	Amplification per Stage.	"B" Battery Voltages.		
		Tap (1)	Tap (2)	Tap (3)
W. E. Co. "D".....	19.0	50-70 v.	250 v.	150 v.
Meiers' (high "mu").....	10.0	"	110 v.	60 v.
Moorhead.....	5.5	"	150 v.	"
Radiotron; UV-201.....	5.1	"	150 v.	"
W. E. Co. "J".....	4.3	"	110 v.	"

3000 meters (cf. the preceding table, page 252) are notable.

**84. Transformer- and Choke-coil-coupled Radio Frequency Amplifiers.**—Transformer- and choke-coil-coupled amplifiers offer some advantage over those of the resistance-coupled type at radio frequencies, in that the parasitic audion capacities which are so deleterious in the latter type can be associated with a proper inductance to give the coupling link—whether transformer or choke-coil—a very high and favorable impedance. Unfortunately this favorable adjustment obtains only at one frequency, or for a narrow band of them. Concerning the transformer-coupled type for radio frequencies and with the tubes available, a one-to-one turn ratio between primary and secondary turns is generally all that can be obtained, hence the transformer does not step-up the voltage and simply acts like a choke-coil of the same number of turns. The only advantage of the transformer is that by conductively separating the primary and secondary, the necessity for providing an isolation condenser to keep the plate voltage off the grid of the next tube, and a biasing resistance, is avoided. In view of this the transformer- and choke-coil-coupled systems may be considered together.

The simplest form of choke-coil amplifier is the regenerative and one-stage amplifier described in Art. 82. Here the choke-coil consists of a variometer, so that the adjustment to make the impedance of the branch circuit formed by the inductance of the variometer and its inherent capacity plus the capacities of the audions, can be made for any wavelength from 150 to 500 meters. Besides the straightforward amplification due to this arrangement, a considerable regenerative effect is caused by the variometer, this action being manifested in the tuned secondary circuit. In the same way, if we attempt to add another stage of this type, regenerative action would be felt in the first variometer circuit. Unrestrained cascading of such stages would yield an amplifier which would be quite unstable and unmanageable. This is due largely, as I have previously remarked, to the feed-back through the grid-plate capacity.

The solution of this difficulty is contained in the curves shown in Fig. 119, which clearly exhibit the damping effect of various inserted resistances in the plate circuit for a typical case. In this case a resistance of 3000 ohms would give an appreciable diminution of the regenerative action, would promote stability, and at the same time would not interfere with the kind of amplification we are interested in; for inserted in series with the choke-coil, or being incorporated in the choke-coil itself by winding it with high-resistance wire, its effect in decreasing the impedance of the coupling link would be almost negligible. Since the feed-back decreases with the wavelength, the insertion of such a stabilizing resistance will not be necessary at the higher wavelengths. This idea might be practically applied, and has been practically applied by English and French

engineers (although their descriptions show that the importance of the grid-plate regenerative action was not clearly appreciated), by winding the choke-coil or transformer with resistance wire or by using an iron-core.

Transformers and choke-coils of fixed value are often employed. In this case the maximum amplification will be obtained, of course, only at one wavelength and the response will fall off as the signals differ from this wavelength. Some very extravagant claims have been made for amplifiers of this type, and the reader is cautioned against being misled into purchasing transformers which are alleged to cover a wavelength range of from say 400 to 4000 meters. Remember that an "amplifier" with but a single turn of wire in the coupling link would cover a range of from 50 to 5,000,000 meters, but it would not be an amplifier, but an absorber! The legitimate extension of the wavelength range of an amplifier with fixed coils can be accomplished in two ways: by regenerative action, and by taking advantage of the variable reluctance due to the skin effect in iron cores. Other extensions are obtained only by decreasing the response at the most favorable wavelength, or tuning point, by the insertion of resistance or its equivalent. Such extension does not seem to the writer to be *bona fide*, and hardly merits the use of the term. The response for wavelengths differing from the tuning wavelength may be improved by careful design, and by employing a choke-coil with a high ratio of  $L$  to  $C$ . The capacity due to the audions and feed-back cannot be conveniently reduced, but the distributed capacity of the variometer may be reduced by decreasing the physical dimensions of the coils, using at the same time a greater number

of turns of smaller wire to get the proper inductance. The writer recommends a construction in which the variometer—both rotor and stator—is wound with two paralleled wires. This gives virtually a transformer with a 1 : 1 ratio, in which the primary and secondary inductances are varied together to preserve this ratio and at the same time to provide a means of adjusting the inductance for each wavelength. One winding is connected to the plate circuit, the other to the grid of the succeeding tube (see Fig. 141). This arrangement is electrically equivalent to a variometer of the same number of turns, but is more convenient, in that the isolation condenser and grid biasing resistance required with the variometer are not necessary. The name “vario-transformer” might be applied to it. The mechanical details, number of turns, etc., will have to be worked out experimentally. Use equal numbers of turns on the rotor and stator. Iron-cored variometers of small size may be designed, incorporating all the desirable features: high ratio; of  $L$  to  $C$ , variable  $L$ , some extension of the operating range by changing flux penetration in the iron, and a loss which will reduce the instability due to regeneration. That a variable transformer (1 : 1 ratio) is preferable to a fixed one is obvious; that the present commercial variometers are too large (giving a large distributed capacity), and possess proportionately intense stray fields, is equally obvious.

A suggestion for the design of a liliputian vario-transformer of the type recommended, suitable for amplification over a wavelength range of 150–500 meters, is contained in Fig. 140. The rotor (moving coil) is wound on two slots cut in a bakelite or hard-rubber disc, with 100 double turns

(50 on each side of the shaft) of No. 36 s.s.c. or enameled wire. The stator (fixed coil) is wound with a similar number of turns, in a haphazard fashion if the wire is found too small to wind regularly. In winding the coils if two spools of wire are available the paralleled wires can be fed out more conveniently. The coil sizes indicated are suitable also for a plate circuit variometer of the type used in the

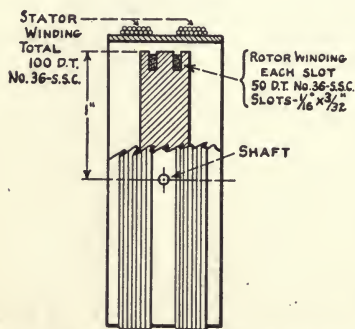

Fig. 140.—Suggested design for lili-puvian vario-transformer.

regenerative and one-stage receiver, Fig. 136.

The application and the electrical arrangement of this type of coupling may be most usefully discussed in relation to the receiver, Fig. 136. Supposing that this receiver is to be further improved by the addition of radio frequency stages, how shall we go about it? The resistance-coupled

amplifier has already been condemned for operation at these wavelengths; the present type of coupling is considered to be most suitable. One or two stages of this kind may be inserted between the regenerative first-stage and the detector, the scheme of connections being indicated in Fig. 141. The proximate old apparatus (Fig. 136) is shown dotted in order to show more clearly the method of addition. The insertion of stabilizing resistances in the plate circuit of the audions (2) and (3), if found to be necessary with the small number of stages likely to be added by the average amateur, will be left to the reader. If such resistances are indicated the vario-transformers are pref-



erably wound with high-resistance wire. It is to be noted that the stabilizer has the same effect, when adjusted so that the grids are positive. The first variometer has been replaced in Fig. 141 by a vario-transformer. This variometer may either be moved up to the last stage, where the grid condenser of the detector audion will serve also as an isolation condenser, or eliminated altogether. It will be found that the settings of the vario-transformers (1) and (2) will be smaller than that of (3), due to the extra capacity

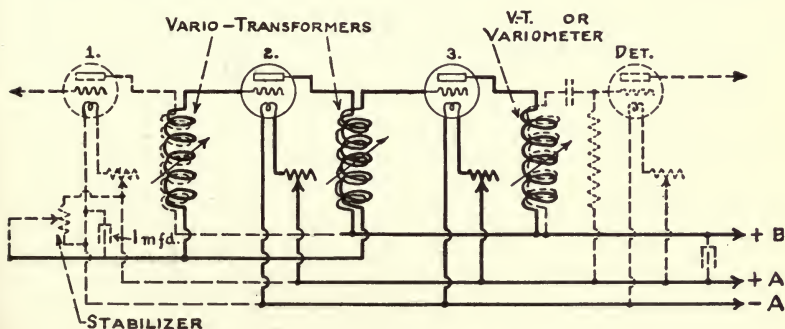

Fig. 141.—Illustrating addition of vario-transformer-coupled amplifier to the receiver of Fig. 136.

across (1) and (2) which is the concomitant of plate-grid feed-back in the audions (2) and (3). It may, therefore, be desirable to wind the last variometer to a larger inductance, or if the range of this is already correct, to reduce the numbers of turns on vario-transformers (1) and (2). In general the adjustments of all three bear a close relation over the useful wavelength range, so that it is quite feasible to simplify the adjustment by connecting them together mechanically in such a way that the proper rotations are made by turning one knob. This should be carefully ar-

ranged in order that no magnetic couplings between the

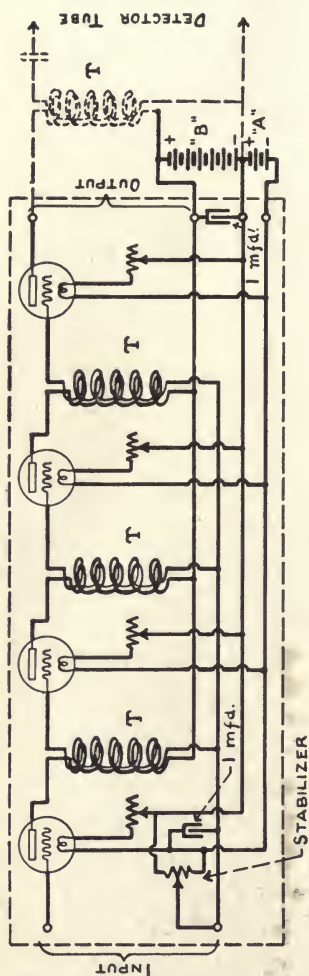

Fig. 142.—Electrical connections of 4-stage 3000-meter transformer-coupled amplifier for super-heterodyne receiver, Fig. 130.

vario-transformers may be introduced. If (2) and (3) are not adjusted, the equivalent of the usual fixed 1 : 1 transformers is obtained; the beauty of this arrangement being that if the operator wishes to realize the extra amplification conditioned by proper adjustment, he may. Separate stabilizers for the first tube, and for the second and third tubes are recommended in place of the single stabilizer shown, and should be shunted by 1 mfd. condensers as indicated in some of the other diagrams (*e. g.*, Fig. 142). The "B" battery should also be shunted by such a condenser.

85. Description of a 3000-meter Amplifier for the Armstrong Super-heterodyne Receiver.—The method of coupling discussed above may be advantageously applied in the construction of a 3000-meter amplifier for use with the Armstrong super-heterodyne receiver described in Art. 78

(Fig. 130). The connections of a 4-stage amplifier are shown in Fig. 142. The coil  $L_2$  of the original circuit (Fig. 130) is to be connected across the input terminals of the amplifier, omitting the connection from  $L_2$  to —“A” shown in that figure. The tuned  $L_3C_3$  circuit, used with the resistance-coupled amplifier to block the low frequency disturbances, while giving slightly more selectivity, is not necessary and in its place one of the transformers may be used as indicated in Fig. 141 by the dotted lines. On account of the exclusive use of one wavelength the coils  $T$  can be adjusted for this wavelength and fixed. Suitable dimensions for these coils are indicated in Fig. 143. As in the case of the vario-transformer, a double winding is provided to obviate the use of an isolation condenser and grid leak which are necessary when one winding (choke-coil) is used. On account of the wide variations in the tubes and wiring of the circuits, the number of turns listed in the table on page 262 are to be accepted suggestively, and the exact arrangements to suit the reader's special conditions may best be determined by direct experiment. The other details will either have been described or will be obvious.

For comparison purposes I have indicated in the following table the amplification per stage that may be expected with this amplifier when several familiar types of tubes are employed. The figures for the “D”, “J” and Moorhead tubes were experimentally determined in 1919.

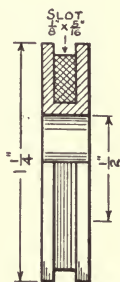

Fig. 143.—Illustrating construction of coupling coils.

Type of Audion.	Amplification per Stage.	Number of Double Turns.
*W. E. Co. "D".....	13.4	700
Meiers' (high mu).....	6.7	1600
*Moorhead.....	4.1	"
Radiotron, UV-201.....	4.0	"
*W. E. Co. "J".....	3.6	"

\* Experimental values.

**86. Stability of Cascaded Amplifiers.**—The regenerative influence of the reintroduction of energy from the plate circuit into the grid circuit of the amplifying audion by means of the various types of back-coupling, electrostatic, electromagnetic and conductive, has already been considered. It has also been noticed that if this energy is reintroduced in sufficient amount a state of self-sustained oscillation is set up in the audion circuits. For a given degree of back-coupling the feed-back is proportional to the amplification experienced by the current in passing through the tube; hence in cascade amplifier systems, where enormous amplification is produced as compared with that produced by a single tube, the tendency of the circuits toward oscillation is proportionately pronounced. The consideration of the natural back-coupling in a cascaded system and its reduction to the point where the system is tolerably stable and devoid of regenerative tendencies is, therefore, a matter of prime importance. This result is to be obtained if possible by actually eliminating the feed-back action and not by reducing the amplification.

The parasitic couplings are of three types: electrostatic, electromagnetic and conductive. We have already had an

example of the electrostatic (capacity) coupling in the regenerative action through the grid-plate capacity of the audion, which is used in the Armstrong tuned-plate circuit. When several audions are used, not only is there feedback from the plate of an audion to its own grid, but also from the plate to every other grid. In a resistance-coupled amplifier, and in the transformer- and choke-coil-coupled types at certain wavelengths, when the grid of the first tube goes positive, its plate goes negative, and the feedback through this tube is anti-regenerative; but the plate of the second audion goes positive, giving through its capacity with the first audion, a regenerative effect. Thus the feedback contributions in the first tube are alternately positive and negative and the stability of the system will depend upon the sum of these effects.\* In these circumstances evidently combinations of 1, 3, 5, . . . stages will be more stable than those of 2, 4, 6, etc. Stability may be provoked in several ways, the most effective of which consists in preventing the electric flux from each tube from reaching any other tube by "grounding" it through a shield which completely incloses the stage except for the small holes required for the connecting wires. Then there will remain only the feedback action through the tubes themselves, which is localized and not so prolific of instability. An example of the application of this method is

\* In technical discussions of the stability of amplifiers I have found the employment of the terms *conditional-* and *absolute stability* convenient, applying to the resistance- and inductance-coupled types respectively; these terms being in analogy with the mathematical series upon the convergence of which the ultimate stability of such systems depends. These terms were defined in papers read at meetings of the Institute of Radio Engineers, Philadelphia Section, June, 1920, and Boston Section, February, 1921.

furnished by the amplifier illustrated in Fig. 144. Here every tube with its apparatus occupies a small metallic cell by itself. Small holes are drilled to pass the necessary connecting wires to the other cells, and usually the cell is

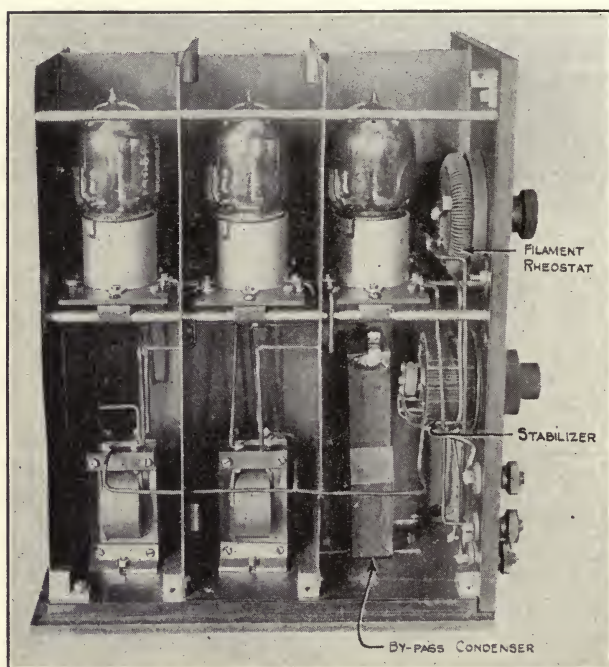

*Fig. 144.—Illustrating assembly of multi-stage amplifier in which the separate stages are inclosed by individual metallic cells.*

connected to the —A battery terminal and grounded. The top and sides of the cell are formed by the sheeting, which covers the inside of the wooden case, and when in position makes a firm electrical contact with the rest of the cell. It is very important that no cracks or holes appear

in the final assembly; the shielding should be complete or left out altogether. Tin-foil will be adequate for electrostatic shielding; sheet copper at least 0.010" thick should be used for electromagnetic shielding at radio frequencies, and sheet electrical-iron  $\frac{1}{16}$ " thick, at audio frequencies.\* The necessity for shielding at low frequencies is practically eliminated by using transformers which are completely iron-clad; the induction from the wires themselves at these frequencies is almost negligible.

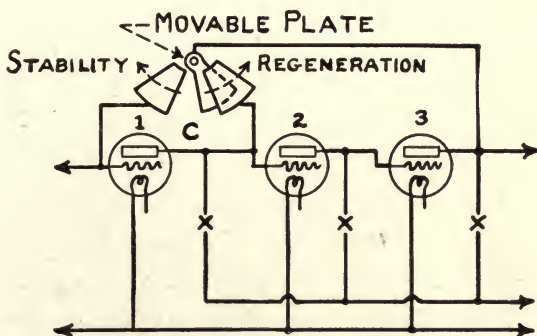

Fig. 145.—Device used by the French for promoting stability or regeneration in a cascade amplifier.

Returning to the capacity coupling at radio frequencies, an interesting connection used extensively by the French for utilizing at will the regenerative effect of a capacity path to alternate tubes, and the damping effect of capacity paths to the others, is illustrated in Fig. 145. This may be used to secure stability, or to increase the signal strength

\* These figures are based upon a shielding effectiveness of 90 per cent. If copper is used for low frequency shielding (1000 cycles) it will have to be .3" thick to give the same effect as .01" copper at 300 meters. Consequently it is better to use iron at these frequencies, for which a thickness of .073" is indicated.





fore conductively coupled together. While this resistance may not amount (in the case of new batteries) to more than 15–20 ohms, yet with the enormous amplification obtained, for example, with a 5-stage amplifier, the feed-back from the last tube to the first tube may be quite appreciable. The “D” section of the circuit is likewise common to all tubes and since the reactance (for example) of two No. 18 wires separated 2 in. is 5.8 ohms per foot at 200 meters, the importance of this inductive coupling is evident. The actual resistance of the wires is of small importance. Other portions of the circuit, “A,” “B,” etc., are common to other stages of the amplifier. The above situation may be remedied in several ways as follows: The “B” battery is first of all shunted by a large condenser, of 1 or 2 mfd. capacity (1 mfd. gives a reactance of  $\frac{1}{10}$  ohm at 200 m.), this condenser being located as close to the apparatus as possible. The other mutual reactances may be reduced by closely associating the two lead wires, by twisting or using two flat strips with their broad faces close together. The most effective scheme is to complete each plate circuit right at the tube through a large condenser, as shown in Fig. 147. If each tube is inclosed by a metallic cell as recommended above, this condenser should also be included in the cell; and in any case its connection should be as close to the position shown in the diagram as possible. If properly designed and proportioned the choke-coils  $L$  will still further reduce the circulating common r.f. currents. They should be connected as shown in Fig. 147 and likewise included in the cell of the tube to which they belong. If the grid leaks are connected together to a stabilizer or common biasing means, similar precautions with respect to their

circuits should be taken. The stabilizer resistance, which will be common to all grids, should be eliminated from the r.f. circuit by shunting with a 1 mfd. condenser, as shown in many of the diagrams (*e. g.*, Fig. 142). If transformers are used, the connection of a condenser between the lower secondary terminal and the filament will be helpful; but not so effective in the case of the 1-megohm leaks.

The free oscillations which are encouraged by the various feed-back effects enumerated will take place at the most favorable frequency, as determined by the  $LC$  constants

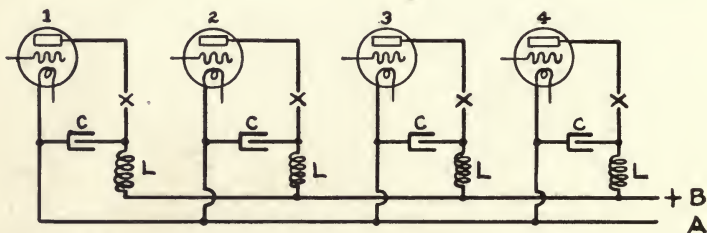

Fig. 147.—Method of reducing instability in cascade amplifier due to inter-stage coupling illustrated in Fig. 146.

of the system and the loss of energy with which the various possible modes of vibration are attended. The short leads and small capacities of the cascaded amplifier cause the oscillation to select a high frequency, usually an ultra-radio frequency, and at such frequencies the reactances of even short leads assume surprising magnitudes. The reactance of the two No. 18 "B" battery leads, for example, which was previously calculated to be 5.8 ohms at 200 meters, will be 58 ohms at 20 meters. And the other modes of energy transfer as well are more effective at the higher frequencies. It is not surprising, therefore, that multi-

stage amplifiers, especially those employing resistance coupling, often persist in developing very high frequency oscillations, which may be above audibility, or above the frequency of the r.f. signals, yet are still troublesome because they aggravate tube noises and prevent the simultaneous efficient use of the tube for the legitimate signal frequencies. This tendency may be checked by the method adopted in the case of power tubes operated in parallel (see Fig. 80 (c)), *i. e.*, by inserting in each grid lead, close to the grid, a small r.f. choke-coil. The coils should be very compact, and may consist of 30 or 40 turns of No. 28 s.c.c. wire wound haphazardly around the thumb or finger.

Many other stabilizing measures are employed, as indicated in special circumstances. In the case of transformer coupling, at both radio and audio frequencies, an increased stability may be often obtained (generally with a sacrifice of amplification) by reversing the terminals of the secondary winding in every other stage. The cores of transformers, tube sockets, and other non-circuital metallic elements are best bonded together and connected to earth. The leakage of radio frequencies into telephone receivers and its reintroduction into the initial stages of the amplifier through the medium of the operator's hand, often invokes oscillations. This may be reduced by inserting a radio frequency trap or filter circuit between the apparatus and the telephones, or by shielding the telephone cords with flexible belden-braid which is connected to the metal receiver cases, and to the ground or —A battery terminal at the other end. The insertion of a telephone transformer between apparatus and telephones is also helpful, but not usually necessary if the telephones have been shielded as above described.

**87. Transformer-coupled Audio Frequency Amplifiers.**—Amplification with audions at the low frequencies of the detected currents is fortunately not attended with the many and divers parasitic actions to which the radio frequency systems are subject. As a result the method is remarkably successful, giving amplifications per stage as high as 40 or 50. It avoids perfection, however, by means of the high efficiency with which extraneous disturbances, tube and battery noises, etc., are amplified. This has already been discussed in Art. 80 and requires no further comment. The practical result is that the number of stages to which amplification by this method can be usefully pushed, is limited by the simultaneous magnification of noises, to two or three. When the operation of a super-telephone, or loud-speaker, is essayed, additional stages may be added to form what is commonly referred to as a "power amplifier." In general such amplification is resorted to only for the production of a greater intensity of sound, and will not result in an increased receiving range.

Presuming that the average amateur will not be interested in "power amplifiers," this discussion will be restricted to the ordinary amplification of the detected currents previous to their passage through the telephones. The use of a 2-stage amplifier is common practice and a resistance-coupled amplifier for this purpose has already been described. The disadvantages of the transformer-coupled amplifier, not inherent but present in 90 per cent. of the commercial types, is the variation of their amplifying power with the variation of the frequency within the speech range. Obviously some distortion of the sound accrues, which increases with the sharpness of tuning and the amount of amplification. It is

to be noted that such effects are not merely additive, that is to say, a transformer whose resonance characteristics give an amplification of 1 unit at 1000 cycles and 4 units at 2000 cycles will not give in two stages an amplification change from 1 to 8 units, but will give 1 unit at 1000 cycles and 16 units at 2000 cycles. The desired flat characteristic is easily obtained by sacrificing amplification, and may be also aided by taking advantage of the variable flux penetration in the iron core, or in a multi-stage amplifier by tuning the trans-

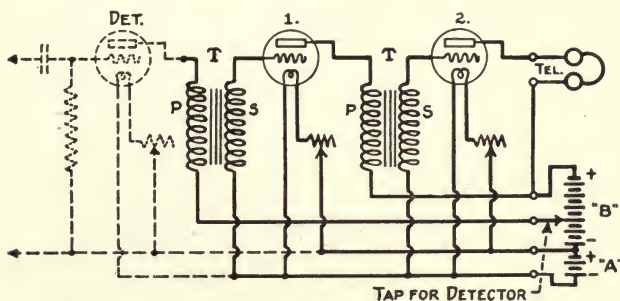
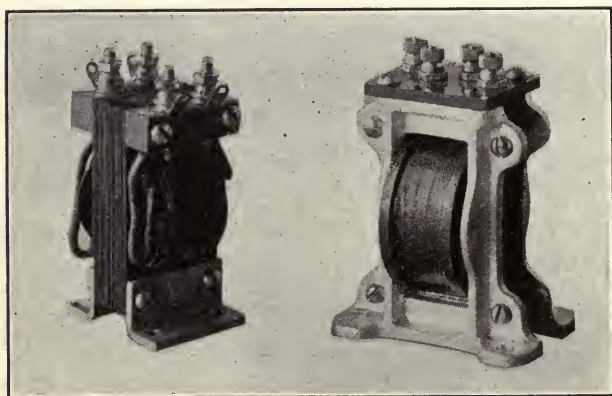

Fig. 148.—Electrical connections of 2-stage transformer-coupled audio frequency amplifier.

formers to different frequencies, or using a special connecting network such as the Campbell filter.

The electrical connections of a 2-stage transformer-coupled amplifier are shown in Fig. 148. The detector audion is indicated by the dotted lines in order to bring out the essential connections of the amplifier. Switches or jacks are usually provided for connecting the telephones either in the plate circuit of the second audion (as shown) for full amplification, or in the plate circuit of the first audion for the use of a single stage. The transformers *T* are of the usual type and many forms are available on the market. Two com-

mercial types are illustrated in Fig. 149. Preference should be given in selecting a transformer to those types which are iron-clad; and by iron-clad I do not mean inclosed in an iron case with five sides and a fibre top, but one which is completely surrounded and shielded magnetically. If the transformers are not shielded in this way, be careful with their mounting and polarity of the secondary connections. In view of the low cost of these transformers it hardly seems

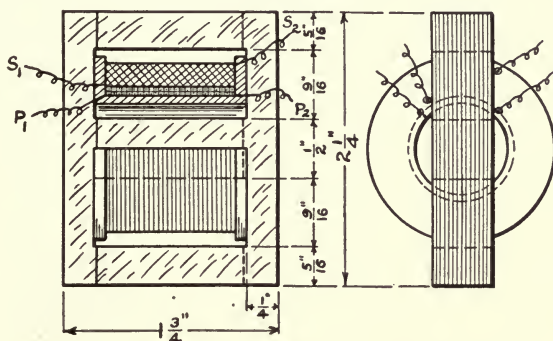

*Fig. 149.—Illustrating two commercial types of transformers for audio frequency amplifiers.*

worth while to try to make them, but if the reader wishes to attempt this, the specifications of Fig. 150 may be helpful. This design is not theoretically correct nor above reproach, and will not give the flat characteristic mentioned above, but represents the average commercial construction.

The completed transformer may be properly shielded by placing it in a box made of soft iron,  $\frac{1}{16}$ " thick. Filament rheostats and other auxiliary apparatus may be pur-

## AUDIO FREQUENCY AMPLIFIER TRANSFORMER

SUITABLE FOR W. E. "J", MEIERS' (LOW MU), MOORHEAD, RADIOTRON;  
UV-201 AUDIONS

WINDING SPECIFICATIONS

	Primary.	Secondary.
No. turns.....	4500	11,000
Conductor.....	No. 40 B. & S.	enamed
No. feet required.....	1050	3500
No. ounces required.....	1/2 oz.	1 1/2 oz.
Resistance (ohms).....	1100	3680
Approx. inductance (1000 c.).....	8 h.	50 h.

*Core.*—Silicon-steel ("transformer sheet") laminations, 10 mil thick; or electrical-steel ("dynamo sheet") 5 mil thick.

*Turn Ratio.*—2.45 : 1.

Normal flux-density ( $\frac{1}{4}$  m.a. plate current) = 5000/cm<sup>2</sup>.

Fig. 150.—Constructional details of audio frequency interstage amplifier transformer.

chased at any radio supply house, and the other constructional details of the amplifier require no comment.

**88. Desirable Electrical Characteristics for Audions Used as Amplifiers.**—At the present time the patent situation respecting the audion is such that the amateur is forced

to accept what a few licensed manufacturers are pleased to market, yet the life of these patents is rapidly nearing its end and it is soon to be expected that the keener competition among a greatly increased number of producers will stimulate the development and sale of better tubes and a greater variety of them. At this date there is little opportunity for the exercise of any choice in selecting tubes for their electrical characteristics. The average characteristics of a number of commercial types have been tabulated on page 231, and the reader will notice that with the exception of the W. E. Co. "D" and the Meiers' types, the electrical constants are about the same in all types, centering about an amplification factor of 6 and an internal plate resistance of 20,000 ohms.

The amplification which a tube is capable of producing is ultimately proportional to the thermionic emission from the filament. Within certain limits the variation of the amplification factor and internal plate resistance with the variation of the grid dimensions and position, take place together in such a way that their quotient remains invariant. Hence, since all the coupling devices which have been described in discussing the cascade amplifier offer a definite impedance in series with the plate resistance of the tube, the drop across this impedance increases with any change in the grid design which increases the amplification factor. It follows that tubes used for amplification should have a high amplification factor ("mu"); not too high, for the dielectric losses in apparatus and distributed capacity and feed-back effects conspire to vitiate the improvement, but appreciably higher than the factors of the present tubes. A "mu" of 20 appears to be about right for most



purposes. The W. E. Co. "D" has a "mu" of 30-60, but requires a plate voltage of 150 for proper operation. I tested the correctness of the above idea by having the "D" tube modified by moving the plate electrode nearer to the grid, thus giving a lower operating voltage (80-100 v.) and a lower "mu" (20). The experiments were remarkably successful and established, as I think, the desirability of a change from the present practice of using "mu's" of 5-10.

Another important characteristic to be secured in the audion is a low grid-plate capacity. Indeed, for radio frequency amplification this is even more important than the increase in "mu," as evidenced by the amplification factors tabulated on page 252 in the case of a resistance coupled amplifier. It is there shown that the "D" tube, even though possessed of a "mu" 3-5 times as great as those of most of the other types, does not produce a proportionately greater amplification on account of the feedback effects through its large grid-plate capacity. The other capacities, plate-filament and grid-filament are of small importance compared to this one. A few progressive manufacturers have placed on the market tubes which have been especially designed to have a small grid-plate capacity. The W. E. Co.'s "N" type, the "Liliputformat" tube of the Germans, and the special tubes used by the English and French (Fig. 151) in which the plate and grid leads are taken out of opposite sides of the glass bulb in-

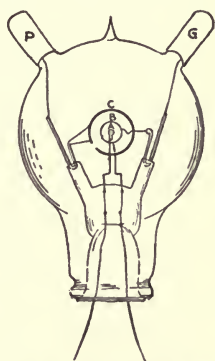

Fig. 151. — Showing method of reducing grid-plate capacity of audion by bringing leads out opposite sides of the bulb.

stead of through the mesh in the usual way, are examples of this. Few of these tubes have the desirable high "mu" properties, however. Some reduction of the grid-plate capacity may be had by bringing out the grid and plate leads from opposite ends of the tube. This is done in the Meiers' tube and is largely responsible for its low g-p capacity. In the Moorhead and some of the other types the grid



*Fig. 152.—Illustrating two commercial sound distributing devices for use with radio telephone-receivers.*

and plate leads have been separated in going through the mesh. This is obviously favorable to a low capacity between these leads, especially in view of the high dielectric constant of glass.

**89. Loud-speakers.**—In its present usage the term "loud-speaker" is applied generically to all electro-phonetic devices employing a means for distributing the sound, such as a large horn. We may, however, distinguish between two

principal classes; those which are merely telephone receivers equipped with a sound distributing device, and those designed to produce, usually with the aid of an audion amplifier, a greater initial sound intensity, which is then distributed by the customary means. Of the first class there are many commercial types, two of which are illustrated in Fig. 152. In each of these instruments an ordinary telephone receiver is applied, this application being clearly shown in the right-hand type. Attachments are also marketed, by means of which the sound-box and horn of the ordinary phonograph may be pressed into service, the receiver being in this case substituted for the reproducer. All these arrangements are of such technical simplicity as to merit no further discussion.

The second class of loud-speaker, which in a strict sense may be regarded as the real loud-speaker, produces sound in great volume and generally finds its chief use in distributing the radio telephone speech and music over large areas, such as in auditoria. The design of a good loud-speaker is a matter of considerable technical difficulty, for as in the case of the amplifier we are face to face with the problem of devising a system which functions indifferently over the entire range of speech frequencies, from 100 to 5000 cycles. As is well known, the mechanical system comprising the vibrating diaphragm and its actuating connections, when acted upon by a periodic force acts very much like an electrical circuit consisting of an inductance, capacity and resistance in series when acted upon by a periodic e.m.f. The analogy is not flawless but will suffice for this discussion. As the electric current depends upon the frequency of the e.m.f. and reaches its maximum value at the frequency for

which the circuit is in resonance, so also in the mechanical case the vibration of the diaphragm depends upon the frequency of the vibro-motive-force and reaches its maximum when this frequency corresponds to the mechanical resonance frequency of the diaphragm. The mechanical resonance frequency is often spoken of as the *natural frequency* of the diaphragm, and in the usual telephone receiver with diaphragm 2.1" diameter and 0.015" thick, averages about 1000 cycles. It obviously depends upon the physical dimensions of the diaphragm, and upon its elastic properties, as well as upon any extra stiffness due to electromagnetic reactions, or pressure reactions from air films, that may be present.

Thus the design of a good loud-speaker involves not only the production of a great volume of sound, but the important matter of accomplishing this without acoustically misrepresenting the electric currents with which it is stimulated. And in order that there shall be no distortion, the vibration of the diaphragm must remain practically constant over a wide range of frequencies. At the date of this writing, so far as I know, there is not a loud-speaker on the market which possesses the last-named characteristic essential for the production of high quality speech\*. The object can hardly be hoped to be attained by means of the ordinary diaphragm system unless by a great sacrifice of sensitivity the tuning of the diaphragm system to a very high frequency is resorted to. The most promising line of attack, and one which any amateur with a little mechanical ingenuity may successfully undertake for himself, is the application of air

\* As the book goes to press a very excellent loud-speaker appears on the market, so that a less pessimistic view of the situation may now be taken.

damping to automatically increase the stiffness of the system with increasing frequency, as in the Wente-Crandall condenser transmitter. This should be reinforced by an electrical network for maintaining constant the current through the windings as the frequency is changed. There are a number of physical "tricks" that await application to this problem, and it is certainly to be hoped that they will speedily receive this application. For there is room for enormous improvement in existing apparatus, and the popular demand for reproduction more appropriate to the high quality of the speech and music being broadcasted by many stations, instead of the present indescribable electro-acoustic abortions ranging from those of the nasal and "phonographic" type to the deep-throated disturbances resembling a distant artillery engagement, will soon stimulate the practical evolution of the more nearly perfect equipment that exists in theory.



## APPENDIX A

### UNDERWRITERS' SPECIFICATIONS GOVERNING INSTALLATION OF RECEIVING ANTENNÆ

EVERY amateur who plans to erect a receiving antenna of the usual elevated type, out-of-doors, whether his house is insured or not, should be guided by the rules and methods of lightning protection prescribed by the National Board of Fire Underwriters. Of course if the building in which the radio receiving station is located is insured, the provision of such lightning protection is usually insisted upon by the insurance company. In view of this the following reproduction of the most recent specifications of the National Board may be of interest:

#### Rule 86. National Electrical Code

#### *Specifications (For Receiving Stations Only):*

##### ANTENNA

(a) Antennæ outside of building shall not cross over or under electric light or power wires of any circuit carrying current of more than six hundred volts, or railway trolley or feeder wires, nor shall it be so located that a failure of either antenna or of the above mentioned electric light or power wires can result in a contact between the antenna and such electric light or power wires.

Antennæ shall be constructed and installed in a strong and durable manner and shall be so located as to prevent accidental contact with light and power wires by sagging or swinging.

Splices and joints in the antenna span, unless made with approved clamps or splicing devices, shall be soldered.

Antennæ installed inside of buildings are not covered by the above specifications.

##### LEAD-IN WIRES

(b) Lead-in wires shall be of copper, approved copper-clad steel or other approved metal which will not corrode excessively, and in no case shall they be smaller than No. 14 B. & S. gauge except that approved copper-clad steel not less than No. 17 B. & S. gauge may be used.

Lead-in wires on the outside of buildings shall not come nearer than four (4) inches to electric light and power wires unless separated therefrom by a continuous and firmly fixed non-conductor that will maintain permanent separation. The non-conductor shall be in addition to any insulation on the wire.

Lead-in wires shall enter building through a non-combustible, non-absorptive insulating bushing.

#### PROTECTIVE DEVICE

(c) Each lead-in wire shall be provided with an approved protective device properly connected and located (inside or outside the building) as near as practicable to the point where the wire enters the building. The protector shall not be placed in the immediate vicinity of easily ignitable stuff, or where exposed to inflammable gases, or dust, or flying of combustible materials.

The protective device shall be an approved lightning arrester which will operate at a potential of five hundred (500) volts or less.

The use of an antenna grounding switch is desirable, but does not obviate the necessity for the approved protective device required in this section. The antenna grounding switch if installed shall, in its closed position, form a shunt around the protective device.

#### PROTECTIVE GROUND WIRE

(d) The ground wire may be bare or insulated and shall be of copper or approved copper-clad steel. If of copper the ground wire shall be not smaller than No. 14 B. & S. gauge, and if approved copper-clad steel it shall be not smaller than No. 17 B. & S. gauge. The ground wire shall be run in as straight a line as possible to a good permanent ground. Preference shall be given to water piping. Gas piping shall not be used for grounding protective devices. Other permissible grounds are grounded steel frames of buildings or other grounded metallic work in the building and artificial grounds such as driven pipes, plates, cones, etc.

The ground wire shall be protected against mechanical injury. An approved ground clamp shall be used wherever the ground wire is connected to pipes or piping.

#### WIRES INSIDE BUILDINGS

(e) Wires inside buildings shall be securely fastened in a workmanlike manner and shall not come nearer than two (2) inches to any electric light or power wire unless separated therefrom by some continuous and firmly fixed non-conductor making a permanent separation. This non-conductor shall be in addition to any regular insulation on the wire. Porcelain tubing or approved flexible tubing may be used for encasing wires to comply with this rule.



## RECEIVING EQUIPMENT GROUND WIRE

(f) The ground conductor may be run inside or outside of building. When receiving equipment ground wire is run in full compliance with rules for Protective Ground Wire, in Section *d*, it may be used as the ground conductor for the protective device.

On account of its connection across the receiving apparatus, the usual electrolytic type of protective device, having a high electrostatic capacity, is unsuitable. Accordingly the

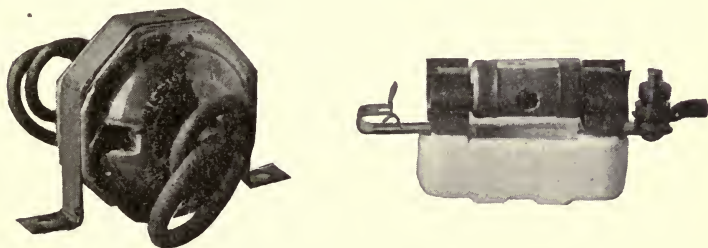

*Fig. 153.—Two commercial types of lightning protective devices for installation with receiving antennæ.*

present practice is to provide a very short spark gap which will break down at 500 volts. Several forms of spark gaps are marketed and may be purchased at almost any radio supply house. Two types are illustrated in Fig. 153.

Some amateurs further protect their receiving instruments by providing the familiar and previously prescribed lightning switch in addition to this protective device.

## APPENDIX B

### RADIO CLUBS

#### THE AMERICAN RADIO RELAY LEAGUE

WHEN one has a hobby it is very pleasant and natural to seek intercourse with others of similar propensities. It is largely to this impulse that clubs and associations of all kinds owe their existence. So in the delightful field of radio, particularly non-professional radio; from the early days amateurs have been wont to band themselves together into radio clubs and associations. Not only is this beneficial for the ordinary reasons, but is of especial value for the proper protection of the rights of the private citizen pursuing radio for amusement or instruction, and in defending it from the onslaughts of the military and of mercenary professionals.

I feel that many of my readers will be novices in this radio business and wish therefore to address to them the appeal that after getting their radio house in order, one of their first moves be to seek out and become affiliated with their local radio club. Here you will come in contact with many kindred spirits, with the radio *beau esprit* of your community, and the ideas to be there gathered, the free instruction, exchanges of experience and so forth, are of inestimable value. The familiar prospect of a radio meeting at which 60-year-old presidents of large institutions and influential men will be found enthusiastically and deferentially discussing the merits of this or that "hook-up" with

14-year-old school-boys is a curious one to contemplate and to think about.

The domain of influence of a local organization is, however, very restricted, and from the point of view of protecting the amateur's rights when radio legislation is contemplated by the Government, is quite impotent. This indicates the need for an organization of national scope; one great organization embracing the grand hierarchy of radio amateurs, and not two or three. Fortunately such an organization, the American Radio Relay League with headquarters in Hartford, Connecticut, exists in this country and is probably the most powerful amateur radio club in the world, having a present membership of ten thousand. In view of the importance of this body in amateur radio affairs, and the plea which is here made that every amateur make it his immediate business to become a member of it, a few remarks on its history and aims will perhaps be appropriate. For this information I am indebted to Mr. K. B. Warner, Secretary of the League and editor of its admirable little journal, "QST."

"The American Radio Relay League is the only association of its kind in the country, being of national scope, entirely non-commercial in its nature, and truly of, by and for the amateur. It is a corporation without capital stock, with a charter under the laws of Connecticut. Its governing body is a board of seventeen directors, elected by popular vote every two years, and no man is eligible to membership of the Board who is in any way financially interested in the manufacture or sale of radio apparatus. The officers of the League are elected by the Board members and serve for two years.

“The purpose of the League is the advancement of private radio, especially as exemplified by the American amateur. We are bonded together for the more effective relaying of friendly messages between our stations, for legislative protection, orderly operating and scientific growth. We have seventeen divisions in our Operating Department, embracing the United States, Canada and Alaska, and each division is in charge of a manager who is a well-known and qualified amateur. In turn he has district superintendents and city managers as assistants, forming a field organization of about 400 men, who keep closely in touch with the individual station owners all over the country. A. R. R. L. is a hobby with these men and all serve in their spare time without financial remuneration, as do all of our officers with the exception of the Traffic Manager and Secretary, who, devoting their entire time to the work at the headquarter’s office, must necessarily make their living thereby.

“The League owns and operates “*QST*” as its official organ, chronicling the activities of the amateurs all over the country. *QST* is devoted solely to the interest of the amateur and that interest is principally the practical improvement of short-wave communication. The A. R. R. L. has represented amateur radio in legislative hearings ever since its formation, and it may be safely said that there have been several occasions when if no League had existed, there would be no amateur radio today. Our substantial prestige at Washington is due largely to our being bonded together in a non-professional organization into which the taint of commercialism cannot enter. We have made our-

selves into that kind of an association which the United States itself can recognize and deal with.

“Thus whenever any matter affecting the amateur is under consideration in Washington the view of the A. R. R. L. is sought. When that expression is secured it represents the best opinion of seventeen men from all over the country who in turn represent the general amateur in their communities. To help in this business of being truly representative of the amateur, there are some 400 clubs scattered throughout the land which are affiliated with the League. Affiliation costs a club nothing and nothing tangible is given in return except a charter, but it bonds all together with hoops of steel in a common brotherhood—that of the American ‘ham.’

“From time to time our Operating Department stages special stunts just to get some fun out of radio. We regularly handle some thousands of messages every night over relay routes, but occasionally knock off and try for a record. The result is that we have handled a message from the Atlantic Coast to the Pacific Coast and got the message back to the east coast again in a total elapsed time of six and a half minutes. Recently we handled messages from the governors of the various states to the President, and forty of the forty-eight messages were delivered, five not starting and three only being lost in the process of transmission. The A. R. R. L. recently conducted experiments in connection with the ‘fading’ of radiotelegraphic signals for the Bureau of Standards, and thousands of curves and data sheets were obtained which are still being analyzed at the Bureau. It was the A. R. R. L. that sent Mr. Paul F. Godley to Scotland in the recent amateur trans-Atlantic

tests, in the course of which about three dozen American amateur stations were heard across the Atlantic.

“It costs nothing to belong to the League except the annual dues of two dollars. One does not even have to be an amateur station owner, the only requirement being that the applicant possess a bona fide interest in amateur radio. The dues include, of course, a year’s subscription to *QST*.”

# INDEX

- A battery** in audion circuit, 46
- A-P tubes**, 183; *see also* **Thermionic rectifier**
- Absolute stability** of cascade audion amplifiers, 263
- Absorption method** of modulation, 143-145
- Aerial**, *see* **Antenna**
- Aeriotron** (audion), 235; electrical characteristics of, 231
- Alternating current circuit**, containing resistance, 28; containing resistance and inductance, 29; containing resistance, inductance and capacity, 29; resonance in, 29, 30
- Alternating currents**, 26-30
- American Radio Relay League**, amateur trans-Atlantic tests, 92; history and purpose (*Appendix B*), 285
- Ammeter**, 14
- Ampere**, def., 15
- Ampere's rule** concerning directions of current and magnetic force, 16
- Amplification**, audio frequency, 236; per stage (3000-meter transformer-coupled amplifier), 262; (3000-meter resistance-coupled amplifier), 252; (2-stage audio frequency resistance-coupled amplifier), 254
- Amplification factor** (of audion), def., 233; comments on, 274
- Amplifier**, audion, 49; (as power amplifier), 51; regenerative audion, 204-214; cascade audion, 238; radio- and audio frequency, 236; resistance, inductance and transformer coupling methods, 239-242; combination regenerative and 1-stage radio frequency, 242; description of 3000-meter resistance-coupled, 249; of 3000-meter transformer-coupled, 260; of 2-stage audio frequency resistance-coupled, 253; of 2-stage audio-frequency transformer-coupled, 271; of vario-transformer-coupled for short wavelengths, 258; stability of cascade, 262
- Amplifier transformer**, construction of radio frequency (3000-meters), 261; construction of audio frequency, 273
- Angular velocity**, def., 29
- Antenna**, action of receiving, 36, 37; Alexander's multiplex, 64; cage construction, 62; circular flat-top, 60; condenser, 88-90; construction of spreaders, 80, 81; construction of cage, 62, 82; description of various types, 59-66; ellipsoidal (vertical), 60; fan, 65; hemispherical, 59, 60; house-top, 85-90; insulation of, 79-82; inverted "L," 61, 62; loaded, 36; loop, 64; requirements of, for transmitting and receiving, 58, 66; symmetrical multiplex, 63; "T" type, 61, 62; triangular flat-top, 61; umbrella, 65; vertical, 60; (radiation of electric wave from), 33
- Antenna coil** (trans.), *see* **Antenna Inductor**
- Antenna efficiency** (trans.), 66, 67
- Antenna inductor**, construction of (trans.), 128, 129; losses in, 128
- Antenna losses**, 66; conductors, 67, 68; earth resistance, 70-78; imperfect dielectrics, 78, 79; leakage and corona, 85; in trees, 79
- Antenna series condenser**, construction of (trans.), 129, 130
- Antennæ for receiving**, Beverage wire, 91, 92; coil (loop), 93-95; (directional properties), 94; single wire, 91; Underwriters' specifications governing installation of, 281
- Antimony**, use of, with silicon in crystal detector, 203
- Armstrong, E. H.**, 101, 205, 223
- Armstrong super-heterodyne receiver**, 223-232; 4-stage resistance-coupled amplifier for, 249; transformer-coupled amplifier for, 260
- Armstrong tuned-plate circuit**, comparison of, for transmitting, 127; fundamental form for oscillating audion, 101, 102; for regenerative amplification (rec.), 210; for transmitting, 122, 123
- Audio frequency amplifier**, 236; construction of 2-stage resistance-coupled, 252; construction of 2-stage transformer-coupled, 270
- Audion**, amplifier, 49, 50; detector, 53-57; invention of 12, 44; modulator, 144, 147; oscillator, 50-53; uses for in radio telephone system, 44; electrical and mechanical data of transmitting types, 103-110; electrical data of receiving types, 231
- Audion detector**, action of (with grid bias), 53-56; (with grid condenser), 56, 57; use of gas in, 233, 234

- Audion oscillator**, flow of power in, 52; self-excited, 52; separately excited, 51; as speech frequency generator, 146
- Audiotron**, detector audion, 233
- Autodyne** detection of c.w. signals, 216, 219
- B battery** in audion plate circuit, 46
- Back-coupling**, *see* **Feed-back**
- Base**, standard bayonet type for audions, 46
- Beat frequency**, 215
- Beats**, formation of, in heterodyne reception, 215
- Beverage**, H. H., 91
- Beverage wire** (receiving antenna), 91, 92; design of for 200-meters, 92; reduction of static and interference by, 93
- Bias**, grid (for amplification), 49; (for detection) 53; (for modulation), 153; use of with autodyne receiver, 220
- Blocking** action of modulator audion, 155
- Borax** solution for chemical rectifiers, 180, 181
- Bridle wires** (antenna construction), 80-82
- Brush discharge** loss in antenna, 66
- Buzzer**, double, for i.c.w. transmitter, 142; test- for crystal detector (rec.), 202
- C battery** in audion grid circuit, 48
- Cage antenna**, 62; construction for reducing conductor losses, 68; construction of, 81, 82
- Capacity** of conductors or condenser, 23, 24; effect of in a.c. circuit, 29; farad, unit of, 24; grid-plate of audion (regenerative effect of), 101, 210; *see also* **Grid-plate capacity**; input of audion, 212; mechanical analogy of in electric circuit, 25; of parallel glass plate condenser, 130; of condensers in parallel and series, 24; specific inductive, 25
- Capacity ground**, 72; *see* **Counterpoise**
- Carborundum** for crystal detector, 203
- Carrier-wave**, 42
- Cascaded audion amplifier**, resistance coupling in, 239, 240; inductance coupling in, 240, 241; transformer coupling in, 241, 242; stability of, 262
- Chaffee**, E. L., 234
- Chalcopyrite** for crystal detector, 203
- Chambers**, F. B., 221
- Chemical rectifier**, construction and operation of, 179-183
- Choke-coil**, action of, in Heising modulation, 148-150; construction of 3 m.h. for r.f., 131; construction of 6-henry for Heising modulation, 151; construction of 50-henry for filter circuit, 178, 179; grid for paralleled tubes (trans.), 135; grid for cascaded amplifier, 267, 269; coupling in audion amplifiers, 240; use of in filter circuit (trans.), 172-177
- Chopper**, use of, in i.c.w. transmitter, 142
- Circuit**, simple electrical, 14; Armstrong super-heterodyne, 226, 227; Armstrong tuned-plate (trans.), 101, 122, 123; (for regenerative amplification), 210; 4-stage resistance-coupled amplifier for 3000 meters, 249; 4-stage transformer coupled amplifier for radio frequencies, 260; combination regenerative and 1-stage r.f. amplifier, 244; vario-transformer-coupled amplifier, 259; 2-stage resistance-coupled amplifier for audio frequencies, 253; 2-stage transformer-coupled amplifier for audio frequencies, 271; Colpitts (trans.), 101, 120, 121; comparison of transmitting, 126; comparison of filter, 177, 178; filter (trans.), 171, 172; fundamental oscillating audion, 97-102; Hartley (trans.), 100, 118, 119; Meissner (trans.), 98, 112, 113; reversed feed-back (trans.), 107, 122, 123; self-rectifying (trans.), 161, 163; tickler coil (trans.), 99, 114-117; (for regenerative amplification), 206
- Clark**, G. H., 99
- Coefficient** of self-induction, 18, 19; of mutual induction, 18
- Coil antenna** for receiving (data for construction of), 93, 94; reduction of interference by, 94; for direction-finding, 94, 95
- Coils** for receiving, losses in, 193-197; construction of, 195, 196
- Colpitts**, E. H., 101
- Colpitts' circuit**, fundamental form for oscillating audion, 101; for transmitting, 120, 121; comparisons of, 127
- Commutator**, synchronous (mechanical rectifier), 184, 185
- Condenser**, blocking (rec.), construction of, 201; construction of .01 mfd. for receiving, 202; construction of .02 mfd. for filter (trans.), 179; construction of antenna series (trans.), 130; capacity of in series and parallel, 24; electric, 23; energy stored in, 24; forms for radio telephone circuits, 25, 26; mechanical analogy of charged, 24; use of oil in, 131; variable, 26, 131
- Condenser antenna**, description of, 88; for installation on house-tops, 89, 90
- Condenser transmitter**, Wente-Crandall, 278
- Conductance**, def., 14; input of audion, 211
- Conduction current**, def., 14
- Conductive back-coupling** in cascaded audion amplifiers, 262
- Constant-current modulation** system, 147, 148
- Constant-potential modulation** system, 148
- Constant-potential rectification** (mechanical), 185
- Continuous wave (c.w.) telegraphy**, modulation methods for, 140; Reinartz receiver



- for, 221-223; situation of telegraph key in, 141; signalling ranges with various powers, 103
- Convection current**, def., 14
- Converter**, audion as, 50, 51
- Counterpoise**, action of, 71, 72; design and construction of, 73-76; combination with direct ground, 76-78; distribution of earth currents with, 72; in cellars, 87; transmitting circuits for use with, 127
- Coupling**, magnetic, of two circuits, 18; parasitic in cascade audion amplifier, 262-268; retroactive in audion, 52, (*see also* **Feedback**); resistance-, inductance-, and transformer- in audion amplifiers, 239-242
- Coupling coils**, construction of, for 3000-meter amplifier, 261
- Coupling resistance**, construction of, for resistance-coupled amplifiers, 250
- Crystal detector**, 203, 204
- Current**, alternating, 26-30; Ampere's rule for relation with H, 16; conduction, 14; convection, 14; (in audion), 46; electric, 13; electron in audion, 47; flow of, in antenna system, 69-72; heating effect of, 15; magnetic effect of, 16; losses due to earth- in antenna systems, 66, 69, 70; eddy- in masts, 82-85.
- Current distribution** in antenna top, 62; in earth, 69; (with direct ground), 69; (with counterpoise), 71, 72; (with direct ground and counterpoise), 76, 77.
- D type audion** (W. E. Co.), 230, 240, 248, 274; electrical characteristics of, 231
- Damon, L. R.**, 10, 153, 154
- Damon's method of grid bias** for modulator tube, 153-155
- Dead-end effect** in receiving coils, 195
- DeForest, Lee**, invention of audion by, 12, 44; -McCandless audion, 234
- Demodulator**, *see* **Detector**
- Detection** of radio telephone signal, 55; audion (with grid bias), 56; (with grid condenser), 57
- Detector**, function of, in radio telephone system, 43; audion, 53-57; crystal, 201-203
- Dick, L. B.**, 195
- Dielectric**, def., 25; losses in antenna, 66, 78, 79; losses in masts and guy wires, 82-85; losses in house-top antennæ, 87; losses in receiving coils, 195
- Dielectric constant**, def., 25
- Direct ground**, combination of, with counterpoise, 76-78; construction of cylindrical, 70, 71; distribution of earth currents in case of, 69; transmitting circuits for use with, 127
- Direction-finding**, 94
- Directive antenna** (loop), 65, 94
- Distortion** due to transformer-coupled amplifier, 270; in telephones and loud-speakers, 276
- Double-circuit tuner**, 192, 193; construction of, 199-201
- E type audion** (W. E. Co.), description and electrical characteristics of, 108
- Earth**, direct, 70; counterpoise, 71
- Earth currents**, distribution of (direct ground), 69, 70; (counterpoise), 72, 73; losses due to, in antenna system, 66, 69, 70
- Earth resistance**, losses due to, 66, 69, 70; reduction by combination of direct ground and counterpoise, 76-78
- Eastham, Melville**, 88
- Eddy-currents**, losses due to, in antenna masts, 66, 82-85
- Edge-effect** in antenna, 62
- Electric condenser**, 23, *see also* **Condenser**
- Electric current**, *see* **Current**
- Electric field** of charged conductor, 22; energy of, 24; of antenna, 33-35, 78, 79
- Electric filter**, *see* **Filter**
- Electric force**, def., 22; lines of, 23; (in wave from vertical antenna), 35
- Electric waves**, 30-33; electric and magnetic forces in, 34 (*see also* **Radio waves**)
- Electricity**, what is it? 13
- Electrolytic rectifier**, *see* **Chemical rectifier**
- Electromagnetic induction**, 17; prevention of, by shielding, 265, 272
- Electromotive force** (e.m.f.), def., 14
- Electron current** in audion, 47
- Electron emission** by filament of audion, 46
- Electron theory** of matter, 13
- Electrostatic capacity**, *see* **Capacity**
- Electrostatic shielding**, 264, 265
- Ellipsoidal antenna**, 60
- Ellis, W. G.**, 10, 195, 205
- Emission**, thermionic, 46
- Ether**, 31
- Ether waves**, *see* **Electric waves**
- Farad**, unit of capacity, def., 24, 25; micro-, 25; micro-micro-, 25
- Faraday's first law of induction**, 17
- Feed-back** in audions, 52; inductive in Meissner circuit, 98, 99; in tickler coil circuit, 99; in Hartley circuit, 100; in Colpitts' circuit, 101; in Armstrong tuned-plate circuit, 101; through grid-plate capacity of audion, 102, 103; regenerative effect of (rec.), 204, 205; effects of, in cascade amplifiers, 263
- Ferris, Malcolm**, 88
- Fessenden, R. A.**, 71

- Filament electrode of audion**, 45; coated platinum, 108, 235; tungsten, 235; life of, in power tubes, 158, 160, 161; construction of transformer for lighting, evaporation of, 160; operation at constant voltage, 160, 161; supply of power for heating (trans.), 157, 161; use of a.c. for heating, 158
- Filament transformer**, construction of (trans.), 159
- Filter**, electrical, for plate voltage supply, 157, 164; Campbell type, 164, 170, 250; comparison of, 177, 178; construction of 50-henry choke-coil for, 178, 179; design of, 169-177; "low-pass," 170; rule for proportioning  $L$  and  $C$  in simple type, 175; simple types of, 171-177; Type II, 170; use of Campbell in resistance-coupled amplifier, 250
- Flat-top antenna**, triangular, 60; circular, 60; rectangular, 61, 62; construction of, 80-82
- Fogg, W. S.**, 10
- Ford coil**, use as modulation transformer, 146
- Frequency**, def. of a.c., 27; relation to wavelength, 22
- Frequency trap for eliminating harmonics** (trans.), 139
- Fundamental wavelength of antenna**, 36; relation to dimensions, 60; voltage distribution at, 82; of single-wire receiving antenna, 91; operation of transmitter at, 60, 138
- Galena** for crystal detector, 203
- Gap**, safety, for transmitting tubes, 105, 134; for lightning protection, 282, 283
- General Electric Co.**, 12, 98, 104, 231
- Godley, P. F.**, 232, 250, 251, 287
- Goldsmith, A. N.**, 12
- Grid electrode of audion**, 45; controlling action of, in audion, 48, 49
- Grid leak resistance**, construction of, for transmitter, 132; action of, with audion detector, 57
- Grid voltage modulation**, 145, 146
- Ground**, counterpoise or capacity, 72; combination of direct and counterpoise, 76-78; direct, 70; transmitting circuits for use with direct or counterpoise, 127
- Ground lead**, 68
- Grounding of masts**, 84; of tin-roof under house-top antenna, 87
- Harmonics**, elimination of, in audion generator, 139; in transformer-rectifier-filter system of plate supply, 166; use of in heterodyne reception, 218
- Hartley, R. V. L.**, 100
- Hartley circuit** fundamental for oscillating audion, 100; comparisons of, for transmitting, 127; for heterodyne oscillator, 100, 218; for master oscillator, 100, 125, 139; for transmitting, 118, 119
- Hazeltine, L. A.**, 9
- Heat**, generation of, by electric current, 15; wavelengths of radiation, 33
- Heising, R. A.**, 149
- Heising modulation system**, 146-153; complete wiring diagram of transmitter using, 189; filter for use with, 172-174, 177
- Hemispherical antenna**, 59, 60
- Henry**, unit of inductance, def., 19; subdivisions of, 10; micro-, 19; milli-, 19
- Hertzian waves**, wavelength of, 33; *see also* Electric waves
- Heterodyne**, detection of c.w. signals, 214; separate, 215, 217; Armstrong super-, 223-232
- Heterodyne oscillator**, construction of, 218; Hartley circuit for, 100, 217
- Honeycomb coils** for receiving circuits, 195, 197
- House-top antennæ**, 85-90
- Howling of amplifiers**, *see* Stability of amplifiers
- Hull, L. M.**, 9
- Hysteresis losses in imperfect dielectrics**, 78
- Impedance of a.c. circuit**, 29, 30; grid-in audion detector, 57; input of audion, 102
- Inductance**, effect of, in a.c. circuit, 29; coupling in audion amplifiers, 240; def., 19; effect of, in electric circuit, 18; mechanical analogy of, 19
- Induction**, electromagnetic, 17; (first law of), 18
- Inductor**, construction of antenna-, for transmitter, 128, 129; form of, for radio telephone circuits, 20; fixed and variable types, 20, 21; *see also* Choke-coil and Variometer
- Input impedance of audion**, 102, 211; conductance due to inductive plate circuit, 211; capacity due to inductive plate circuit, 121; effect of, in radio frequency amplifier, 247
- Insulation of antenna system**, 79-82; of counterpoise, 74; of guy-wires, 83; of single-wire receiving antenna, 91; of antenna masts, 83; of lead-in, 82
- Insulators**, 14; 17-in. for antenna and counterpoise, 74; construction of lead-in, 82; porcelain egg-, 83
- Interrupted continuous wave (i.c.w.) telegraphy**, def., 140; compared with "spark" telegraphy, 141; modulation for, 142; position of telegraph key in, 141
- Interstage transformer**, construction of, for audio frequency amplifier, 273
- Inverted "L" antenna**, description of, 61, 62
- J type audion** (W. E. Co.), 230, 246, 247; electrical characteristics of, 231
- Jones, Lester**, 221
- Joule effect (loss)**, 15

- Kenetrons**, 183; *see also* Thermionic rectifiers
- Lead-in** of antenna, 62; cage construction for, 62, 68; insulation of, 82
- Leakage**, losses due to, in insulators, 85
- Lee, J. W.**, 71
- Light**, velocity of, 31; wavelengths of, 33
- Lightning protection**, 91; underwriters' specifications for, 281
- Liliputian audions**, 235, 275
- Liliputian vario-transformer**, construction of, 258
- Lines of force**, electric, 23; magnetic, 16
- Loop antenna**, 64, 93; data for construction for receiving, 94; design of, for receiving, 94, 95; for direction-finding, 94, 95
- Losses** in antennæ, 66, 85; in antenna conductors, 67, 68; in antenna coil, 128; in antenna condenser, 129-131; due to earth currents, 69, 70; in masts, 82, 85; in receiving coils, 194-197; in switches for receiving coils, 195, 196; in trees, 79; Telefunken method for reducing in masts, 84, 85
- Loud-speaker**, description, 276; distortion due to, 277; design, 278, 279
- Loughlin, W. D.**, 10, 195
- Low-pass filter**, 170
- Magnetic field** of antenna, 33-35; energy stored in, 20; of solenoid, 16; due to straight current, 16
- Magnetic force**, def., 16; Ampere's rule for direction of, 16; in wave from simple antenna, 35
- Master oscillator**, Hartley circuit for, 100, 125, 139
- Master-oscillator system** compared with self-excited generator, 96, 126; circuit for transmitting, 124, 125; adjustment of, 139; modulation of, 143 (*see also* Grid voltage modulation)
- Masts**, construction of metal, 82, 83; insulation of, 83; losses in antenna, 66, 84, 85; Telefunken method of reducing losses in, 84, 85
- Mechanical analogy** of inductance, 19; of charged condenser, 24
- Mechanical data** of power audions, 103-110
- Mechanical rectifiers**, 184; constant-potential, 185; construction of, 187
- Meiers' audion**, 230, 246, 248; electrical characteristics of, 231
- Meissner, A.**, 98
- Meissner circuit** compared with other transmitting circuits, 127; fundamental form for oscillating audion, 98, 99; for transmitting, 112, 113; complete wiring diagram of transmitter using, 188, 189
- Micro-henry**, def., 19
- Micro-farad**, def., 25
- Microphone**, function of, in wire telephone, 38; use of simple, for modulation, 144
- Miller, J. M.**, 9, 71, 78, 102
- Milli-henry**, def., 19
- Mineral detector**, *see* Crystal detector
- Modulation** in wire telephony, 39; in radio telephony, 42; in c.w. and i.c.w. telegraphy, 140; methods in radio telephony, 143; by grid voltage variation, 145, 146; by power absorption, 143-145; by plate voltage variation, 147-155; constant-current and constant-potential systems, 147, 148; Heising system of, 149; filters for use with grid voltage and Heising, 171-178
- Modulation transformer** for grid voltage modulation, 146; for plate voltage modulation, 152; construction of, for Heising system, 154
- Modulator tube**, operation of, 147, 148
- Moorhead audion**, 230, 246, 276; electrical characteristics of, 231
- Motor-generator** for plate voltage supply, 157, 187, 188
- Motors**, rewinding old, for plate voltage supply, 187
- Multiple-tuned antenna**, Alexanderson's, 64; symmetrical, 63
- Mutual conductance**, def. (audion), 233
- Mutual inductance**, def., 18
- Mutual induction**, coefficient of, *see* Mutual inductance
- N type audion** (W. E. Co.), 235, 275
- Natural frequency** of diaphragm, 278
- Negative resistance** due to regenerative audion, 205, 211, 212
- Ohm**, unit of resistance, 15
- Ohm's law** for steady currents, 14
- Oil**, use of, in transmitting condensers, 131; dehydration of, 131
- Oscillating audion circuits**, Armstrong tuned-plate, 101, 102; Colpitts, 101; Hartley, 100; Meissner, 98; reversed feed-back, 101; symmetrical, 163; tickler coil, 99
- Oscillations**, generation of, by audion, 50-53; ultra-radio frequency (in paralleled transmitting tubes), 135; (in cascade amplifiers), 269
- Oscillator**, audion, flow of power in, 52; construction of heterodyne-, 218
- Overloaded receiving tubes** for transmitting, 110; for master oscillator, 125
- P type audion** (G. E. Co.), 104
- Parallel operation** of transmitting tubes, 134-136
- Peanut audions**, 235
- Perikon**, crystal detector, 203
- Period** of a.c., 27
- Periodic time**, 27
- Phase**, lead and lag, in a.c. circuit, 28-30

- Pierce, G. W., 9, 170  
 Plate electrode of audion, 45  
 Plate resistance of audion, def., 233  
 Plate voltage modulation, 146-155  
 Potentiometer, *see* Stabilizer  
 Power, flow of, in audion oscillator, 52;  
 transfer from audion to antenna, 98;  
 supply of, for plate circuit (trans.), 156,  
 157; supply of, for filament, 157-161;  
 method of, supply using step-up trans-  
 former, filter and rectifiers, 163, 164  
 Power amplifier, audion as, 51; use of, for  
 operation of loud-speaker, 270  
 Power audions, electrical and mechanical  
 data of, 103-110; operation of, in parallel,  
 134  
 Priess, W. H., 221  
 Protective device (lightning), 182, 283  
 Protective ground wire, 282  
 Protective measures for transmitting audi-  
 ons, 133, 134; for lightning, 281  
 Radiation resistance of antenna, 66, 67; of  
 condenser antenna, 90  
 Radio compass, *see* Direction-finding  
 Radio Corporation of America, magnetic  
 modulator, 145  
 Radio frequency amplifier, 236; combination  
 regenerative and 1-stage, 242; construc-  
 tion of 3000-meter resistance-coupled for  
 Armstrong super-heterodyne receiver, 249;  
 construction of 3000-meter transformer-  
 coupled for Armstrong super-het. receiver,  
 260; performance of resistance-coupled,  
 247  
 Radio telephony, development of, 12; com-  
 pared with radio telegraphy, 43; carrier-  
 wave system of, 42; (principles of), 41-  
 43  
 Radio waves, production of, 33; transmission  
 of, 36; reception of, 36  
 Radiotron (trans. audions), UV-204, UV-203,  
 UV-202, description and electrical data of,  
 104-107; (receiving audions), UV-201,  
 UV-200, electrical characteristics of, 231  
 Ratio of transformation in audion trans.,  
 135, 137  
 Receiver, single circuit, *see* Single-circuit  
 tuner; double circuit, *see* Double-circuit  
 tuner; Armstrong super-heterodyne, 223-  
 232; autodyne for c.w. signals, 221-223;  
 construction of employing combination  
 regenerative and 1-stage radio frequency  
 amplifier, 244; heterodyne for c.w. sig-  
 nals, 217; Reinartz for c.w. signals, 221-  
 223; simple type employing crystal detec-  
 tor, 201-204  
 Receiving antenna, Beverage wire, 91, 92;  
 loop or coil, 92-95; requirements for, 58,  
 59, 90, 91; single wire, 91; Underwriters'  
 specifications governing installation of,  
 281  
 Rectification, action due to asymmetrical  
 audion characteristic, 55; constant-poten-  
 tial (mechanical), 185; in grid circuit of  
 audion, 57; in plate circuit of audion, 54  
 Rectifier, thermionic, 47, 183; constant-  
 potential mechanical, 185; construction of  
 chemical, 181-183; construction of me-  
 chanical, 186, 187; connections of thermi-  
 onic, 184; description of chemical, 179,  
 180; mechanical, 184, 185; use of, for sup-  
 plying d.c. plate voltage, 157, 164  
 Regeneration, action in audion circuit, 204;  
 due to plate inductance, 211  
 Regenerative amplification with audion,  
 204-214  
 Reinartz, J. L., 221  
 Reinartz tuner for c.w. signals, 221-223  
 Resistance, def., 14; unit of, 15; effect of in  
 a.c. circuit, 28-30; of conductors in series  
 and parallel, 15; losses due to, in antenna,  
 66; speech controlled, in Heising modula-  
 tion, 148; high frequency of coil, 194, 195;  
 negative due to regenerative audion, 205,  
 211, 212; def. of plate, of audion, 233;  
 coupling in audion amplifier, 239  
 Resistance, coupling, construction of, for  
 cascade amplifiers, 250  
 Resistance-coupled amplifier, def., 239; de-  
 scription of 3000-meter for Armstrong  
 super-het. receiver, 249; description of  
 2-stage audio frequency, 252; effect of  
 audion capacities in, at radio frequencies,  
 247  
 Resistance, grid, construction of (trans.),  
 132  
 Resonance in a.c. circuit, 30; mechanical, in  
 telephone receiver, 277, 278  
 Retro-active coupling in audion, 52; *see also*  
 Feed-back  
 Reversed feed-back circuit, comparisons  
 with others for trans., 127; fundamental  
 form for oscillating audion, 101; for  
 transmitting, 122, 123  
 Right-hand rule for electric current and  
 magnetic force, 16  
 Round, H. J., 71  
 Round's round ground, 71  
 Safety gap for power tubes, 105, 134  
 Self-excitation, fundamental circuits for  
 (audion), 97-103  
 Self-excited audion oscillator compared with  
 separately excited audion oscillator, 96;  
 adjustment of, 137, 138  
 Self-heterodyne, *see* Autodyne  
 Self-induction, coefficient of, 18; *see also*  
 Inductance  
 Self-rectifying circuits (trans.), using one-  
 half a.c. cycle, 162; using both halves of  
 a.c. cycle, 162, 163  
 Separate-heterodyne, detection of c.w. sig-  
 nals, 215, 217

- Separately excited audion oscillator, 51; compared with self-excited a.o., 96
- Shielding cascade audion amplifier, 263-265; telephone cords, 269
- Signal-static ratio of receiving antenna, 91
- Signalling range, c.w. with various powers, 103; i.c.w. and spark, 141
- Silicon, fused, for crystal detector, 203
- Simple-harmonic alternating current, 27
- Single-circuit tuner, 192, 193; construction of, 197, 198
- Single-wire receiving antenna, 91
- Sinusoidal alternating current, 27
- Spark coil, use of, as modulation transformer, 146
- Specific inductive capacity, 25
- Speech, nature of, 39; frequencies present in, 40
- Speech-signal in radio telephony, 42; detection of, 54, 55
- Spreader, construction of, 80, 81; wood and metal, 80, 81
- Squirrel-cage antenna construction, 62
- Stability of cascade audion amplifiers, 262; conditional- and absolute-, 263
- Stabilizer for i.f. amplifier, 245, 251; use of resistance in plate circuit, 255
- Static, 90, 91; reduction by Beverage wire, 92
- Super-heterodyne, Armstrong, for short wave amplification, 223; 3000-meter resistance-coupled amplifier for use with, 249; 3000-meter transformer-coupled amplifier for use with, 260
- Switch for receiving coils, construction of mica-insulated, 196, 197
- Symmetrical multiplex antenna, 63
- Symmetrical oscillating circuits, 163
- Synchronous commutator, 184, 185
- Synchronous motor, use of, with mechanical rectifier, 186
- T type antenna description of, 61, 62
- Telefunken Company, use of umbrella antenna, 65; method of reducing mast loss, 84, 85; Meissner circuit, 98
- Telegraph key, connection of, in c.w. transmitter, 114
- Telegraphy, c.w., *see* Continuous wave telegraphy
- Telephone receiver, function of, in wire telephony, 38
- Telephony, principles of wire, 38-41; development of radio, 12; comparison of wire and radio, 43
- Test buzzer for crystal detector, 202
- Thermionic emission, 46; current in audion, 46
- Thermionic rectifier, 47, 183
- Tickler coil, association of, with single-circuit tuner, 197, 198; construction of (rec.), 206
- Tickler coil circuit, comparisons with other transmitting circuits, 127; effect of tickler coupling in receiving, 208; fundamental form for oscillating audion, 99; for regenerative amplification (rec.), 206; operation of (rec.), 207; for transmitting, 113-117
- Transformer, construction of (for Heising modulation system), 151; (for heating filaments of power tubes), 159; (of step-up for power supply for plate circuit), 167-169; coupling in audion amplifier, 241; construction of radio frequency amplifier, 268; construction of audio frequency amplifier, 273; input in audion amplifier, 49; output in audion amplifier, 49; step-up, for plate supply, 157; vario-, 257
- Transformer-coupled audion amplifier for radio frequencies, 254; description of 3000-meter for Armstrong super-heterodyne, 260; description of 2-stage audio frequency, 270; amplification per stage, 262
- Transformer-rectifier-filter system, use of, for plate supply, 157, 164; complete wiring diagram of transmitter using, 188, 189; design of, 165-168
- Transmission of radio waves, 36
- Transmitter, adjustment of self-excited, 135-138; adjustment of master-oscillator, 139; assembly of, 190
- Transmitter, telephone, *see* Microphone
- Transmitting antenna, requirements for, 58, 59, 66, 67
- Transmitting circuits, audion, collection of, 110-125; comparison of, 126; complete, 188, 189; Armstrong tuned-plate, 122, 123; Colpitts, 120, 121; Hartley, 118, 119; master-oscillator, 124, 125; Meisner, 112, 113; reversed feed-back, 122, 123; tickler coil with inductive plate coupling, 116, 117; tickler coil with inductive grid coupling, 114, 115
- Trees, losses due to, in antenna field, 79
- Triangular flat-top antenna, 60
- Tubes, vacuum, 44; *see* Audion; power-, *see* Power audions
- Tuned-plate circuit, comparison with other transmitting circuits, 126, 127; fundamental form for oscillating audion, 101; for regenerative amplification (rec.), 210; for transmitting, 122, 123
- Tuner, double-circuit, def., 192, 193; construction of, 199-201
- Tuner, single-circuit, def., 192, 193; construction of, 197, 198
- Tuning of a.c. circuit, 30; of transmitter, 135-138; receiving antenna, 36, 37; single-circuit and double-circuit methods of, in receiving, 192
- Tuning apparatus, construction of (rec.), 194; losses in (trans.), 66, 68, 128, 132; receiving, 102-201
- Type II filter, 170

- Umbrella antenna**, 65
- Underwriters' specifications** for lightning protection and installation of receiving antennæ, 281
- Variable condenser**, 26
- Vario-coupler**, def., 199
- Vario-transformer**, def., 257; design and construction of liliputian, 257; use of, in radio frequency amplifier, 257-251
- Vario-transformer-coupled amplifier**, description of, 259
- Variometer**, principle of, 21; use of, as choke-coil in transmitter, 121; use for tuning receiver, 201, 214; use of, in radio frequency amplifier, 245; use of, in regenerative amplification, 210; description of liliputian, 257
- Velocity**, angular, 29; of light, 31
- Vertical antenna**, 60
- Volt**, unit of e.m.f., 15
- Voltage node** in loaded antenna, 77
- Voltmeter**, 14
- Warner, K. B.**, 10, 285
- Wavelength**, def., 32; relation to frequency, 32; of X-ray, heat, light and radio waves, 33; fundamental of antenna, 35, 36; best operating in transmitting, 67; adjustment of, in transmitter, 135-137
- Waves**, electric, 30-33; double-cored, 40; guided, 40
- Western Electric Company**, 12, 100, 101, 108, 149
- Wire telephony**, principles of, 38-41; current variations due to vowel sounds in, 39
- Wireless telephony**, using voice currents directly, 40
- Wiring diagrams**, complete for transmitter, 188, 189
- Wood spreaders**, 80-82
- X-radiation**, 31; wavelengths of, 33
- X-ray**, *see* X-radiation
- Zincite** for crystal detector, 203









THIS BOOK IS DUE ON THE LAST DATE  
STAMPED BELOW

AN INITIAL FINE OF 25 CENTS  
WILL BE ASSESSED FOR FAILURE TO RETURN  
THIS BOOK ON THE DATE DUE. THE PENALTY  
WILL INCREASE TO 50 CENTS ON THE FOURTH  
DAY AND TO \$1.00 ON THE SEVENTH DAY  
OVERDUE.

JAN 11 1933

NOV 9 1933

MAR 15 1946

JUN 17 1982

LC 19369

504606

**UNIVERSITY OF CALIFORNIA LIBRARY**

