

VACUUM TUBE VOLTMETERS

Other Books
by
JOHN F. RIDER

THE METER AT WORK
FREQUENCY MODULATION
SERVICING BY SIGNAL TRACING
THE OSCILLATOR AT WORK
THE CATHODE-RAY TUBE AT WORK
SERVICING SUPERHETERODYNES
PERPETUAL TROUBLE SHOOTER'S MANUAL
VOLUME I VOLUME VII
VOLUME II VOLUME VIII
VOLUME III VOLUME IX
VOLUME IV VOLUME X
VOLUME V VOLUME XI
VOLUME VI
ALIGNING PHILCO RECEIVERS
AUTOMATIC FREQUENCY CONTROL SYSTEMS
SERVICING RECEIVERS BY MEANS OF RESISTANCE
MEASUREMENT
AN HOUR A DAY WITH RIDER
ON
RESONANCE AND ALIGNMENT
AUTOMATIC VOLUME CONTROL
ALTERNATING CURRENTS IN
RADIO RECEIVERS
D-C VOLTAGE DISTRIBUTION IN
RADIO RECEIVERS

VACUUM TUBE VOLTMETERS

by
JOHN F. RIDER



JOHN F. RIDER PUBLISHER, INC.

404 Fourth Avenue

New York City

Copyright, 1941, by
JOHN F. RIDER

*All rights reserved including that of translation into the
Scandinavian and other foreign languages*

Printed in the United States of America

Dedicated to

MY MOTHER

*The longer I know her,
the better I love her.*

AUTHOR'S FOREWORD

THE Vacuum-Tube Voltmeter, since its inception in 1895, has developed into one of the most valuable aids to the electronic research worker. Originally used to measure high-frequency voltages in connection with laboratory operations, it now has developed into an extremely valuable r-f, a-f and d-c voltage measuring device for the engineer and the maintenance man and for indicating purposes in complete communicating systems.

This book on the Vacuum-Tube Voltmeter is intended as a practical exposition of the numerous types of such measuring devices, with the direct intention of providing a source of information for the engineer, student and serviceman, so that if he desires to compare different types, establish their principles of operation or construct them, all the facts are available from one source.

As is evident, a general understanding of the basic operation of the diode and triode types of tubes is taken for granted, although a brief review of each is furnished. This attitude is taken on the grounds that the man who works with vacuum-tube voltmeters is at least familiar with the vacuum tube. The beginner who is first learning elementary facts about radio theory, has no need for data on vacuum-tube voltmeters. At the same time, the use of equations relating to vacuum-tube voltmeter operation, such as are usually expected by the engineer, are also omitted because of the practical laboratory work that was done during the preparation of this text. The engineer who is interested in one certain type of vacuum-tube voltmeter, will find that type not only described, but presented in completed form with full constants for all of the components. Furthermore, since this is a practical book, rather than a theoretical book, there is no particular need for formulae.

As shown by the references and the bibliography, the text is a symposium of all the work which has been done in many countries upon vacuum-tube voltmeters. At the same time, however, original work also has been done, as attested by facts contained in this volume which are not available any place else.

In connection with the original laboratory work, we wish to express our gratitude to J. Avins who has done much research work upon

vacuum-tube voltmeters, who has several valuable vacuum-tube voltmeter patents to his credit and under whose supervision the various finished units described in this volume were built. He was also greatly instrumental in the gathering of the numerous references contained in this book.

JOHN F. RIDER.

February, 1941.

TABLE OF CONTENTS

CHAPTER I. FUNDAMENTALS OF VACUUM-TUBE VOLTMETERS—1. Advantages of the V-T Voltmeter—2. A Simple D-C V-T Voltmeter—4. Simple A-C V-T Voltmeter—6. Importance of Waveform—Peak, RMS, and Average Values—7. V-T Voltmeters Respond to Peak, Average, or RMS Values—11. Balancing or “Bucking” Circuits—12.

CHAPTER II. DIODE VACUUM-TUBE VOLTMETERS—13. The Diode Characteristic—13. Diode Rectifier Operation—15. Simple Diode V-T Voltmeter—17. Peak Diode V-T Voltmeter—Series Type—17. Peak Diode Voltmeter—Shunt Type—19. Shunt-Type Diode Voltmeter Circuit—21. High-Voltage Shunt-Type Peak V-T Voltmeter—22. Values of R and C for Peak V-T Voltmeters—23. “Contact Potential” Effect in Diode V-T Voltmeters—25. Slide-Back Diode V-T Voltmeter for Positive Peak Voltages—27. Slide-Back Diode V-T Voltmeter for Negative Peak Voltages—29. Slide-Back Diode V-T Voltmeter for Trough Voltages—30.

CHAPTER III. TRIODE VACUUM-TUBE VOLTMETERS—32. Plate Detection V-T Voltmeters—32. Half-Wave Square-Law V-T Voltmeter—33. Half-Wave V-T Voltmeter Using 1N5-GT—35. Full-Wave Square-Law V-T Voltmeter—38. Full-Wave V-T Voltmeter Using 1N5-GT—39. Ideal Square-Law V-T Voltmeter—40. Determining Bias for Square-Law Operation—42. Peak Plate-Rectification V-T Voltmeter—44. Grid-Rectification V-T Voltmeter—45. Grid-Rectification V-T Voltmeter Using a 1G4-G Triode—49. The Self-Bias or Reflex V-T Voltmeter—51. Self-Bias V-T Voltmeter Using a 954 Acorn Tube—53. Balancing or Bucking Circuits—55. Balancing Circuit Using Voltage Divider—57. Cathode Balancing Circuits—58. Two-Tube Bridge Circuit—59.

CHAPTER IV. SLIDE-BACK VACUUM-TUBE VOLTMETERS—61. Triode Slide-Back V-T Voltmeter—61. Error in Slide-Back V-T Voltmeters—62. Input Resistance of Slide-Back V-T Voltmeter—63. Slide-Back V-T Voltmeter Measures Positive Peak—64. Pre-

- venting Injury to Meter—64. Measurement of D-C Voltages with Slide-Back V-T Voltmeter—65. Input Circuit of Slide-Back V-T Voltmeters—66. Space-Charge Slide-Back V-T Voltmeter—66. Amplifier Type Slide-Back V-T Voltmeter—68.
- CHAPTER V. RECTIFIER-AMPLIFIER VACUUM-TUBE VOLTMETERS—70. Diode Rectifier Used with D-C V-T Voltmeter—71. Reflex Rectifier Used with D-C V-T Voltmeter—72. Rectifier-Amplifier V-T Voltmeter Using a Voltage Divider—74. Rectifier-Degenerative Amplifier V-T Voltmeter—76. General Radio 726-A V-T Voltmeter—77.
- CHAPTER VI. TUNED VACUUM-TUBE VOLTMETERS—81. Basic Tuned V-T Voltmeter—82. Input Circuit and Probe—82. Multiplier—83. Amplifier Design—84. Use as a Comparison V-T Voltmeter—85. A-F Output Connection—86.
- CHAPTER VII. AUDIO-FREQUENCY AND LOGARITHMIC VACUUM-TUBE VOLTMETERS—87. Simple Audio-Frequency V-T Voltmeter—88. High-Sensitivity A-F V-T Voltmeter—91. Television Amplifier V-T Voltmeter—93. Logarithmic V-T Voltmeters—96. Comparison of Linear and Logarithmic Scale—97. Logarithmic Voltage Scale Provides Linear Decibel Scale—98. Wide Range of Logarithmic Scale—98. Types of Logarithmic V-T Voltmeter—99. Logarithmic Milliammeter—100. Logarithmic V-T Voltmeter Using Logarithmic Milliammeter—101. Controlled-Amplifier Logarithmic V-T Voltmeter—102. Amplifier-Rectifier Type Logarithmic V-T Voltmeter—105.
- CHAPTER VIII. VACUUM-TUBE VOLTMETERS FOR D-C VOLTAGE, CURRENT, AND RESISTANCE MEASUREMENTS—108. Input Resistance and Grid Current in D-C V-T Voltmeters—109. Accuracy of D-C V-T Voltmeters—110. The Slide-Back V-T Voltmeter for D-C Voltage Measurements—110. A Simple Center-Zero D-C V-T Voltmeter—111. Isolating Resistor—"Signal Circuit" Probe—113. Polarity Considerations in D-C V-T Voltmeters—114. Measuring Voltages Between Points Above Ground—114. Obtaining a Center-Zero Deflection for Galvanometer Applications—115. A Single-Tube Degenerative V-T Voltmeter—116. Balanced Push-Pull D-C V-T Voltmeter—118. The RCA Junior VoltOhmyst—121. Resistance Measurements with the V-T Voltmeter—V-T Ohmmeters—122. Direct-Reading Vacuum-Tube Ohmmeter—123. V-T Ohmmeter with External Voltage Supply—125. Slide-Back V-T Ohmmeter for High Resistances—128. Sensitive Current Measurements with the D-C V-T Voltmeter—129. A Degenerative D-C Amplifier Used in V-T Microammeters—130. A Multi-Range Microammeter

- Using Inverse Feedback—131. Ultra-Sensitive Current Measurements—132.
- CHAPTER IX. DESIGN AND CONSTRUCTION OF VACUUM-TUBE VOLTMETERS—133. High Input Impedance—133. Wide Frequency Range—133. Wide Voltage Range—133. Accuracy and Permanance of Calibration—134. Type of Response—Waveform Error—134. Stability and Protection against Overload—134. Simplicity of Design and Ease of Operation—135. Compensating for the Effect of Variations—135. Reducing Errors at High Frequencies—136. Bypassing Considerations—137. Selection of Tubes—137. Selection of the Meter—138. Resistor Considerations—139. Grid-Circuit Considerations—140. Reduction of Leakage in D-C V-T Voltmeters and V-T Ohmmeters—141. Power Supply Considerations—142. Completely Regulated Voltage Supply—143. Extending the Voltage Range of A-C V-T Voltmeters—143. Extending the Voltage Range of D-C V-T Voltmeters—145. Constructional Notes—145.
- CHAPTER X. CALIBRATION AND TESTING OF V-T VOLTMETERS—146. Choice of Standards—146. General Precautions—147. Use of Tube-Tester Transformer—147. Variac or Other Variable Ratio Transformers—148. Set-Up for A-C Calibration—148. Use of Decade Voltage Divider—149. Extra Condensers for 60-cycle Calibration—149. Waveform Considerations—150. Consistency Check—151. Use of Outer Linear Scale—151. Correction Curve for Slide-Back V-T Voltmeters—151. Calibration of V-T Voltmeters at Ultra-High Frequencies—152. Measuring the Input Impedance of A-C V-T Voltmeters—152. V-T Voltmeter as a Comparison Voltmeter—153. Use of Log-Log Paper for Square-Law V-T Voltmeters—154. Checking a Decibel or Logarithmic Calibration—155. Calibration of D-C V-T Voltmeter—155. Measuring Grid Current and Input Resistance of D-C V-T Voltmeters and V-T Ohmmeters—156.
- CHAPTER XI. APPLICATIONS OF V-T VOLTMETERS—157. Amplifier Stage Measurements—157. Signal Tracing—Checking Amplifier and Receiver Operation—158. Measuring Transformer Turn Ratio—158. Power-Supply Measurements—159. Low-Frequency Impedance Measurements—159. Measuring Inductance, Capacitance, and Resistance—160. V-T Voltmeter for Measuring Alternating Currents—162. V-T Voltmeters in Modulation Indicators—162. V-T Voltmeters in Wave Analyzers—163. D-C Voltage, Current, and Resistance Measurements—163. Commercial V-T Voltmeters—165.
- BIBLIOGRAPHY—171.
- INDEX—177.

Chapter I

FUNDAMENTALS OF VACUUM-TUBE VOLTMETERS

THE vacuum-tube voltmeter was born of necessity. During the many years which saw the development of radio and electronics, innumerable measurements were required many of which could not be made with conventional meters of the moving-coil, moving-iron, thermocouple, or metallic rectifier types. Among these measurements were audio-frequency and radio-frequency voltages extending to well above 100 megacycles, gain measurements in radio receivers, modulation percentage, the "Q" of coils and condensers, inductance and capacitance, power output, transformer turn ratios, peak voltages, and a host of other measurements. To enable these measurements to be made, a radically different type of voltmeter was required. This problem was met by combining the d-c moving-coil meter with a vacuum-tube circuit, and it was this combination which became known as the vacuum-tube voltmeter.

As far back as 1895 when the diode was invented by Fleming, the diode was used as a rectifier to make possible the measurement of high-frequency voltages. Thus was born the first v-t voltmeter. With the invention of the triode by de Forest in 1907, engineers were quick to realize the improvement which could be made by using it in v-t voltmeters. Since that time both diodes and triodes have been widely used in v-t voltmeters.

Although the modern v-t voltmeter is basically similar to its early forerunner, a great many improvements have been made in both the tubes and the circuits which are employed. One of the more recent and important tube developments is the miniature acorn tube. Because of its small size and low losses, the acorn tube makes possible improved v-t voltmeter performance at high radio frequencies. Two types of acorn tubes which are widely used in v-t voltmeters are shown in Fig. 1-1. The RCA type 954 is an r-f pentode, while the RCA type 955 is a triode which is often used as a diode by connecting the grid and plate together.

Developments in the d-c meters which are used as indicators in v-t voltmeters have not been so great as those in the tubes, because the

meters were already developed to a high degree when the vacuum tube was invented. For the most part, improvements in meters have been limited to providing more sensitive and rugged movements at a lower cost. To an appreciable degree, however, the remarkable performance

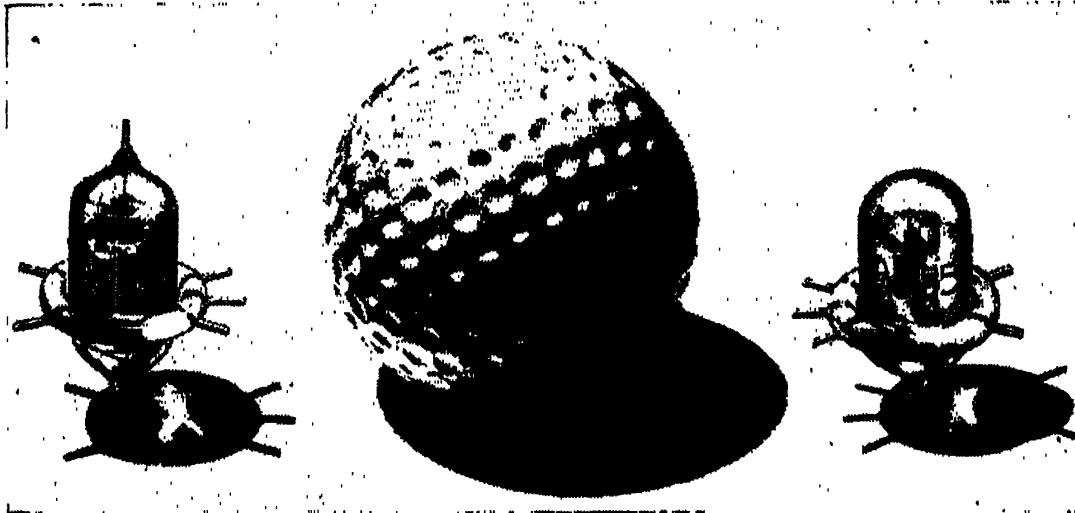

Courtesy RCA Mfg. Co., Inc.

Fig. 1-1. Two types of acorn tubes which have improved v-t voltmeter performance at high frequencies. Compare their size with that of the golf ball.

of the modern v-t voltmeter must be attributed to the highly perfected meter which forms the indicating element of the combination. A representative d-c microammeter of the type used in v-t voltmeters is shown in Fig. 1-2.

Advantages of the V-T Voltmeter

Since the vacuum-tube voltmeter was conceived to perform functions which were beyond the capabilities of other forms of measuring devices, it stands to reason that it must possess numerous advantages. These are many, but the one of prime importance and of greatest value to all those who have occasion to make voltage measurements under varying conditions, is that *the vacuum-tube voltmeter draws a negligible amount of current from the circuit under test.* In other words, it does not disturb or load the circuit under test to any appreciable extent. This is of especially great importance in radio circuits because so often the amount of power available in the circuit under test is measured in microwatts. Since a conventional meter draws thousands of times the total available power, it is clear that it cannot be used to make measurements in such circuits.

With the v-t voltmeter, however, this limitation is largely overcome because the voltage under measurement is applied to the grid of a vacuum tube, rather than directly to a meter. Since the grid of the

vacuum tube used in the measuring device draws no current during normal operation of a v-t voltmeter, it follows that no current is drawn from the voltage source being measured.

High Sensitivity—The v-t voltmeter provides a greater sensitivity than a meter, because the v-t voltmeter combines the amplification provided by the tube with the inherent sensitivity of the meter. Thus in Fig. 1-3a, which is a schematic of a simple v-t voltmeter, a small change in grid voltage—without the flow of grid current—is capable of changing the plate current by a considerable amount. If a sensitive meter is used to measure this change in plate current, it is clear that the v-t voltmeter by utilizing the amplification of the tube, is capable of measuring much smaller voltages than could be obtained if the meter were coupled directly to the circuit being measured.

Fig. 1-2. A phantom view of a commercial permanent-magnet, moving coil meter. The positions of the coil, core and pole pieces are clearly shown.

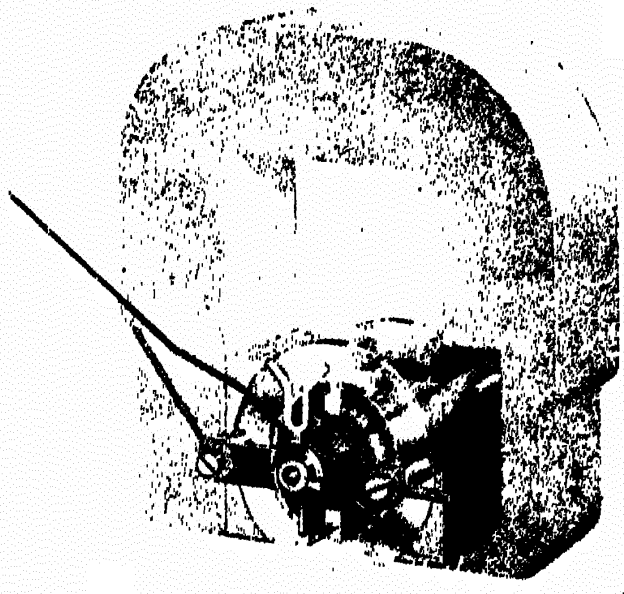

*Courtesy of
Weston Electrical
Instrument Company*

Greater Ruggedness—For a given measurement, the meter required in conjunction with a v-t voltmeter can be much less sensitive than a meter which could be employed directly. Because of this, meters which are used in v-t voltmeters are more rugged, and so are better able to withstand accidental overload than conventional meters of the same sensitivity. In addition to permitting the use of a less sensitive meter, v-t voltmeter circuits are usually designed so that additional protection is afforded the meter. These refinements will be discussed in detail later, but for the present it is sufficient to note that the current through the meter can never rise above the maximum plate current of the vacuum tube with which it is associated, no matter how large an input voltage is applied to the grid.

Wider Frequency Range—An extremely important advantage of the v-t voltmeter over conventional meters is the fact that it makes pos-

sible measurements of a-c voltages over an extremely wide frequency range. Special v-t voltmeters have been developed which permit measurements to be made at frequencies of the order of several thousand megacycles, but even the well-designed commercial v-t voltmeter can measure up to 100 megacycles. Because of the increasing importance of the ultra-high frequencies in many branches of the electronic art, this is an important advantage of this type of instrument. As new tubes are developed and higher frequencies are exploited, there is every reason to believe that these same tubes and circuits will be employed in v-t voltmeters to enable measurements at these higher frequencies.

Use of Ordinary Meters—Although the v-t voltmeter can be used with equal facility for all measurements, whether in high- or low-impedance circuits, the conventional meter still retains advantages when d-c or low-frequency (power) measurements are to be made in low-impedance circuits. These advantages are greater portability and (usually) greater accuracy, because of the fewer variables involved in using a single meter as against using a meter which is combined with a vacuum tube, power supply, and other components. In high-impedance circuits, however, the v-t voltmeter is unquestionably superior to the conventional meter.

A Simple D-C V-T Voltmeter

The basic operation of a vacuum-tube voltmeter is comparatively simple. The instrument in elementary form is a combination of a vacuum tube, the required operating voltages, and a plate-current meter used as an indicator. Two types of tubes are used in v-t voltmeters: the triode, as the basic type of multiple-element tubes, and the diode. In view of the fact that the latter is discussed later in a separate chapter, we shall at this time consider the preliminaries of just the triode type.

The essence of operation of the triode type of v-t voltmeter lies within the amplifying property of the tube. This is so even when the tube is used as a triode rectifier or detector, rather than as an amplifier. As a result of this amplifying property, a small voltage applied between the control grid and the cathode or filament, whichever type of electron emitter is used, results in a large variation of the plate current. In Fig. 1-3a is shown the circuit of an elementary type of triode v-t voltmeter, which is in many respects similar to the more elaborate instruments described later. A d-c milliammeter is located in the plate circuit, between the plate battery and the plate to indicate the plate current. The unknown voltage to be measured is applied to the input of the tube between the grid and the grid bias terminal.

Suppose now that the bias voltage is adjusted so that, with no voltage applied to the input, the plate current is reduced to zero. Then if a positive voltage is applied to the input terminals it offsets all or part

of the negative bias and the plate current will increase from zero. The greater the positive voltage, the greater will be the increase in the plate current. As shown in Fig. 1-3b, the plate current increase is almost proportional to the voltage applied to the input terminals so that the plate current can be taken as a measure of the voltage applied to the grid.

In practice, the milliammeter scale is marked in terms of the input voltage (E_x) which must be applied to the grid to cause a given plate current to flow. Thus when $E_x = 2$ volts the plate current $I_p = 4.0$ ma. This interpretation of the plate current in terms of the corresponding grid voltage is called *calibration* of the instrument. The meter scale shown in Fig. 1-3c has the original milliampere scale, while the appearance of the scale on the same meter after it has been calibrated for use in this simple v-t voltmeter is shown at Fig. 1-3d. It is customary to omit the plate current designations since these are not of interest to the user of the v-t voltmeter.

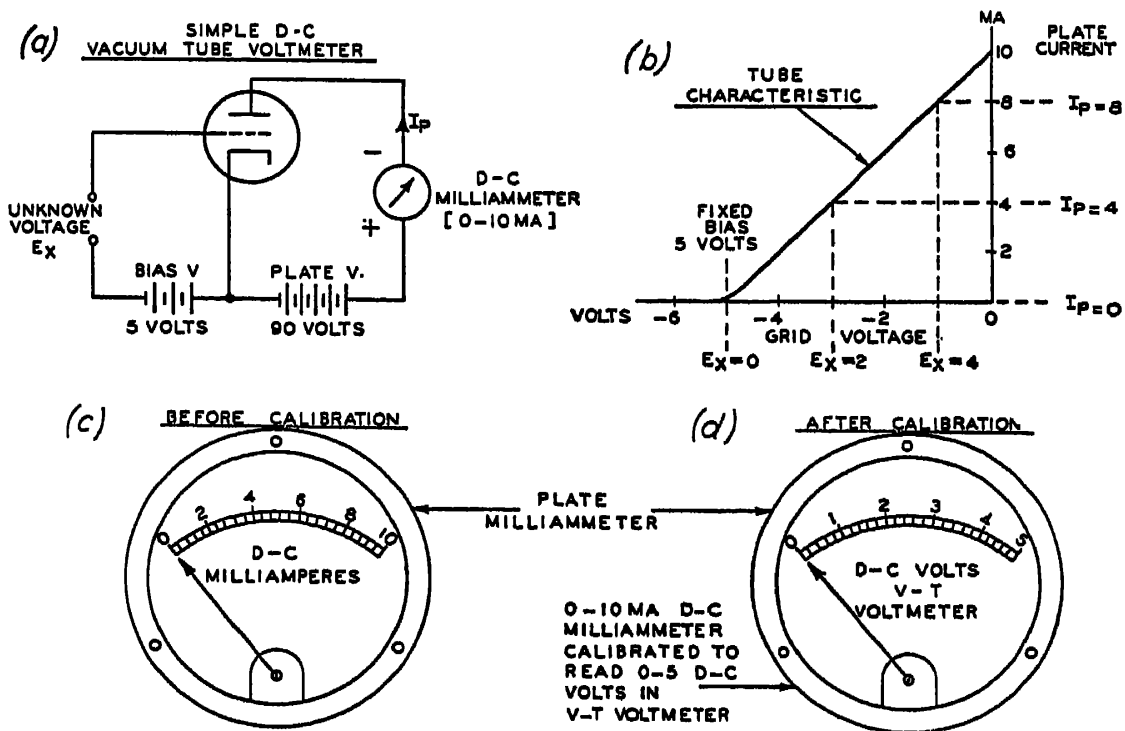

Fig. 1-3. The schematic and operation of a simple d-c v-t voltmeter. The appearance of the milliammeter scale before and after calibration illustrates the manner in which the plate-current reading is interpreted in terms of the unknown voltage applied to the grid.

The application of such a simple v-t voltmeter to the measurement of direct voltages is immediately clear. To measure any positive d-c voltage between 0 and 5 volts, it is only necessary to connect this voltage to the input terminals of the v-t voltmeter and the value of the unknown voltage can be read on the meter scale.

Needless to say the v-t voltmeter which we have just described is a very simple voltmeter indeed, but because of its simplicity its usefulness is greatly limited. Thus such a v-t voltmeter can be used only for the measurement of d-c voltages over a limited range. To overcome this limitation, however, circuits have been developed which permit the measurement of all d-c voltages, regardless of polarity, and all a-c voltages over a wide range of frequencies. These v-t voltmeters will be described in detail later.

A Simple A-C V-T Voltmeter

We have previously described the basic manner in which a vacuum tube and d-c milliammeter are arranged to measure *d-c* voltages. We shall now describe how a similar simple set-up is arranged for the measurement of *a-c* voltages, in which classification we include of course all alternating voltages, so that the simple v-t voltmeter to be described can be used for measuring 25-cycle, 60-cycle, audio-frequency, and radio-frequency voltages.

The schematic is shown in Fig. 1-4a. You will observe that this circuit is essentially the same as that shown in Fig. 1-3a; however the manner in which the circuit operates for the measurement of a-c voltages is different than for d-c voltages.

As Fig. 1-4b shows, the tube is initially biased to cutoff so that no plate current flows when there is no a-c voltage applied to the grid. When an input a-c voltage is applied, however, the grid will be swung alternately positive and negative. On the negative grid swings, which make the grid more negative, there can be no further decrease in the plate current because the tube is already biased to cutoff. On the positive grid swings, however, the bias is offset and the plate current will follow the grid voltage so that there will be a pulse of plate current which is similar in shape to the positive half of the input a-c voltage applied to the grid.

As a result of this action, the current flowing through the plate milliammeter will consist of a series of pulses. But the plate current meter cannot follow these pulses—unless they are very slow—perhaps 1 cycle per second. At all frequencies above a few cycles per second, which means all audio, commercial a.c., and high frequencies, the meter indicates the *average* value of the plate current that flows through it. The dotted line in Fig. 1-4b shows that the average plate current is 3.2 milliamperes, or 32% of the peak plate current.

As in the case of the d-c vacuum-tube voltmeter which we previously described, it is possible to calibrate the scale of the d-c plate milliammeter used in the a-c v-t voltmeter in terms of the a-c voltage applied to the grid. When no voltage is applied, the plate meter will read zero and so this point on the scale can be marked zero volts. As the a-c

voltage is increased from zero, the plate current will increase, and the meter reading will increase in proportion to the magnitude of the applied a-c voltage. In this way each point on the scale can be assigned that value of input a-c voltage which is required to produce the particular

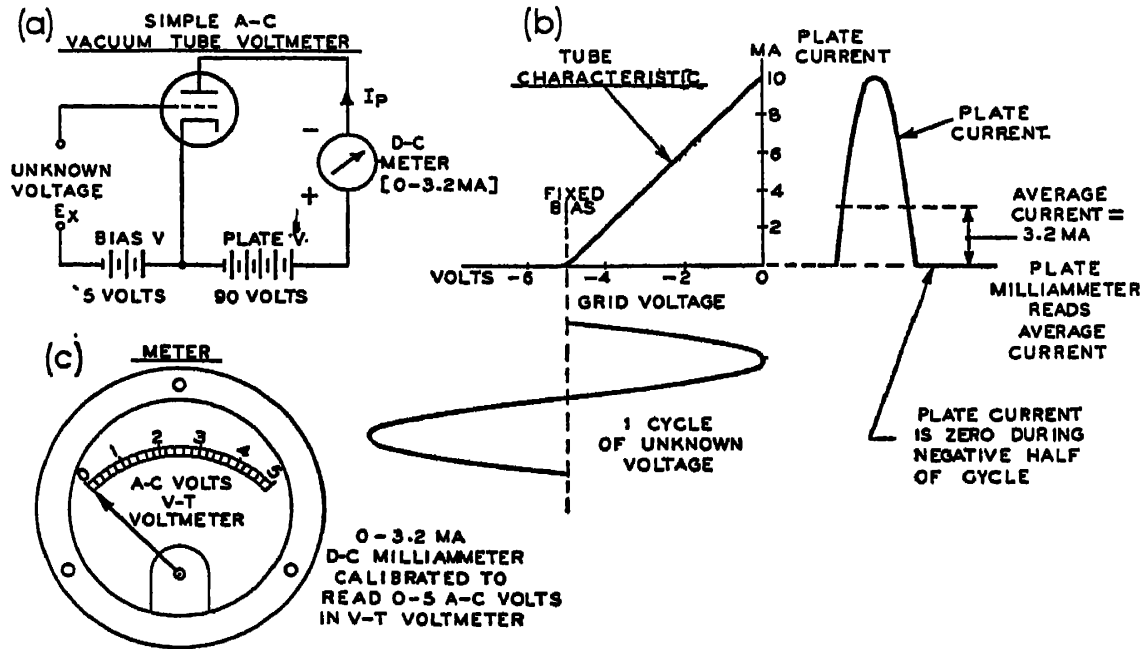

Fig. 1-4. In this simple v-t voltmeter for the measurement of a-c voltages the grid is biased to cutoff. Thus only the positive halves of the input voltage cause a flow of plate current through the d-c milliammeter which is calibrated to read a-c volts.

value of d-c current through the meter for that scale reading. A typical calibration for an a-c vacuum-tube voltmeter of the type we have been describing is shown in Fig. 1-4c.

Importance of Waveform—Peak, RMS, and Average Values

One of the significant details associated with vacuum-tube voltmeters, belonging in this discussion of fundamentals, is that relating to waveform. Thus v-t voltmeters are often referred to as being of the *peak* type, as being calibrated to read *rms* values, as having a response proportional to the *average* value of the input voltage, etc. All of these comments are related to the *waveform* of the voltage being measured and to the *response* of the v-t voltmeter used for the measurement.

D-C Voltage Wave—The simplest type of waveform is that of a direct voltage such as is shown in Fig. 1-5a. It is a straight line. Here there is no possibility of confusing the *peak*, *rms*, and *average* values because all are equal.

Sine Voltage Wave—When we refer to an a-c voltage, it is usually understood that the waveform of that voltage is similar to the smooth

sine wave shown in Fig. 1-5b. When an a-c wave has this sine shape, it is said to be pure or undistorted, and is entirely free of harmonics. The voltage wave which is supplied by the power companies usually has a waveform which is very nearly a sine wave.

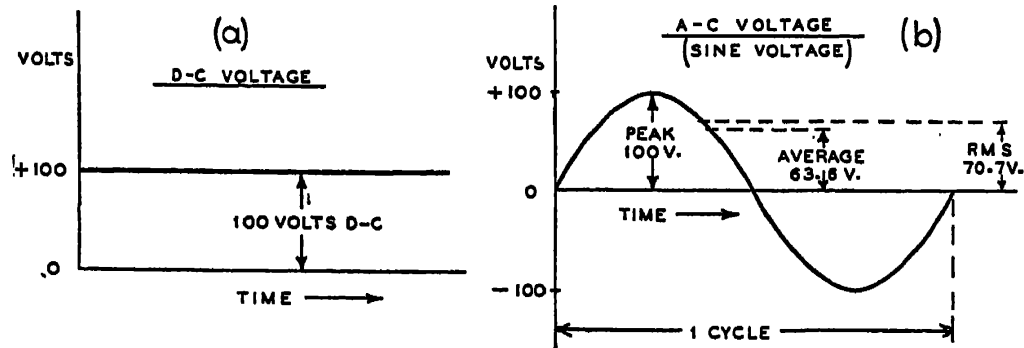

Fig. 1-5. The simplest waveform, direct current, is a straight line; the fundamental a-c waveform is a sine wave. Note the designations of the *peak*, *average* and *rms* values.

However not all waves have a sine waveform. Whenever a wave is not pure sine in shape, the change in waveform is due to the presence of harmonic frequencies. Thus the “complex” waves shown in Figs. 1-6, 1-7, and 1-8 are made up of a fundamental frequency plus a number of harmonic frequencies. In general the more the waveform departs

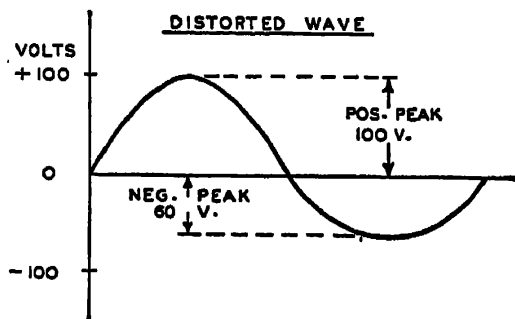

Fig. 1-6. An unsymmetrical complex wave which is distorted because its positive and negative peaks are unequal.

from a sine wave, the greater are the number and amplitude of the harmonics present.

Peak Value—In describing the waveform of various types of voltages and currents being measured, it is often necessary to refer to the *peak* value of the wave. As the name implies, the peak value is the highest voltage which the wave reaches. For the sine wave shown in Fig. 1-5b, the peak value is clearly equal to 100 volts. The peak values of the complex waves shown in subsequent figures are indicated in each drawing. Note that regardless of the complexity of the waveform, the peak value is in all cases the highest value reached by the voltage.

For some distorted (complex) waves, the positive peak value is different from the negative peak value. This occurs when the wave is not symmetrical and in such cases it is necessary to refer to the *negative-*

peak voltage as well as the *positive-peak* voltage. An example of such a wave is shown in Fig. 1-6. Recognition of this condition is important in v-t voltmeter measurements because of the difference in measured values under different conditions.

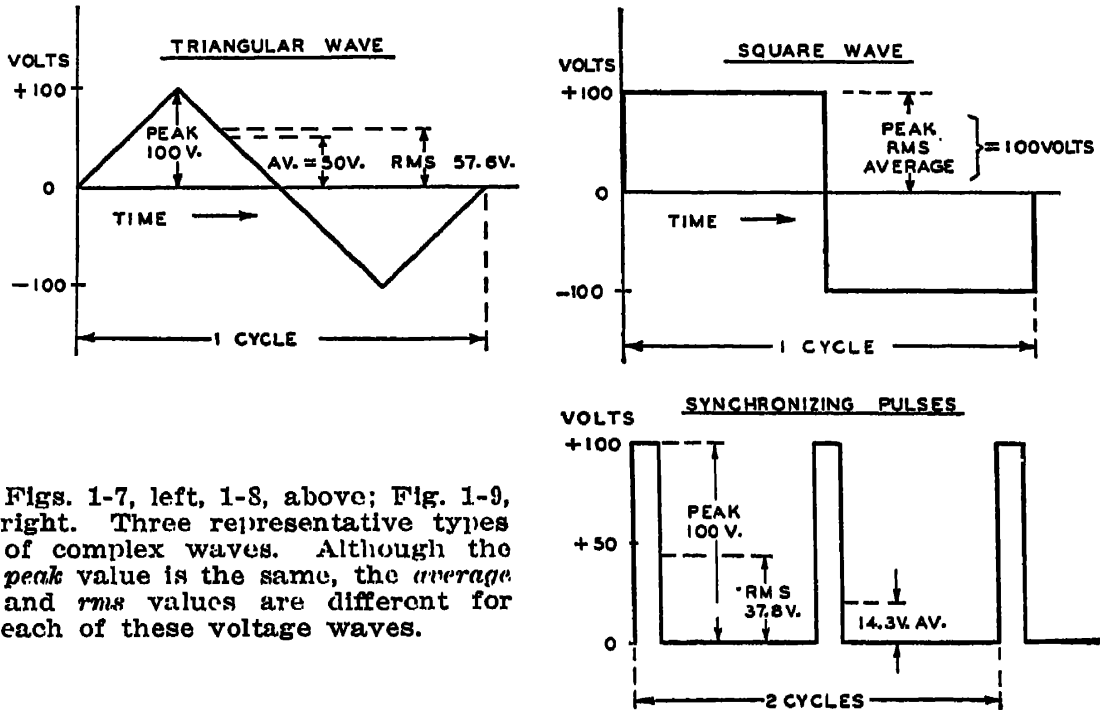

Figs. 1-7, left, 1-8, above; Fig. 1-9, right. Three representative types of complex waves. Although the peak value is the same, the average and rms values are different for each of these voltage waves.

Average Value—Another term used in connection with a-c voltages and currents is the *average* value. Just as the name implies, the average value of an a-c voltage is equal to the value obtained by averaging the instantaneous values of voltage. When this averaging process is carried out for a sine wave, it turns out that the average value of the wave is equal to 63.6% of the peak value. As shown in Fig. 1-5b, the average value of a sine wave of voltage having a peak value of 100 volts, is 63.6 volts.

The average value is not always equal to 63.6% of the peak value. It all depends upon the waveform. For a sine wave it is 63.6%. For a triangular wave like that in Fig. 1-7, it is 50%. For a square-top wave like that shown in Fig. 1-8 it is 100%. For the special type of wave which represents the synchronizing pulse in a television system and shown in Fig. 1-9, the average value is only 14.3% of the peak. The reason for this low average value is that the peak value of the wave lasts for only a small fraction of the cycle. During the remainder of the cycle the voltage is zero, so that the average value is brought down to a figure very much lower than the peak. In the case of rectified waves, the average value of a half-wave rectified pulse is 31.8% of the peak, as shown in Fig. 1-10, and is 63.6% of the peak in a full-wave rectification system, as shown in Fig. 1-11.

Among other reasons, the average value of an a-c wave is important because the reading of a d-c meter is proportional to the average value of the current or voltage. Thus in explaining the operation of the simple a-c v-t voltmeter shown in Fig. 1-4, we mentioned that the d-c meter responded to the *average* value of the current wave in the plate circuit. Another example where the average value is important is in the reading of a milliammeter which measures the plate current of a class A amplifier tube. With a signal applied, the plate current of such a tube is similar to that of the *pulsating* wave shown in Fig. 1-12. The

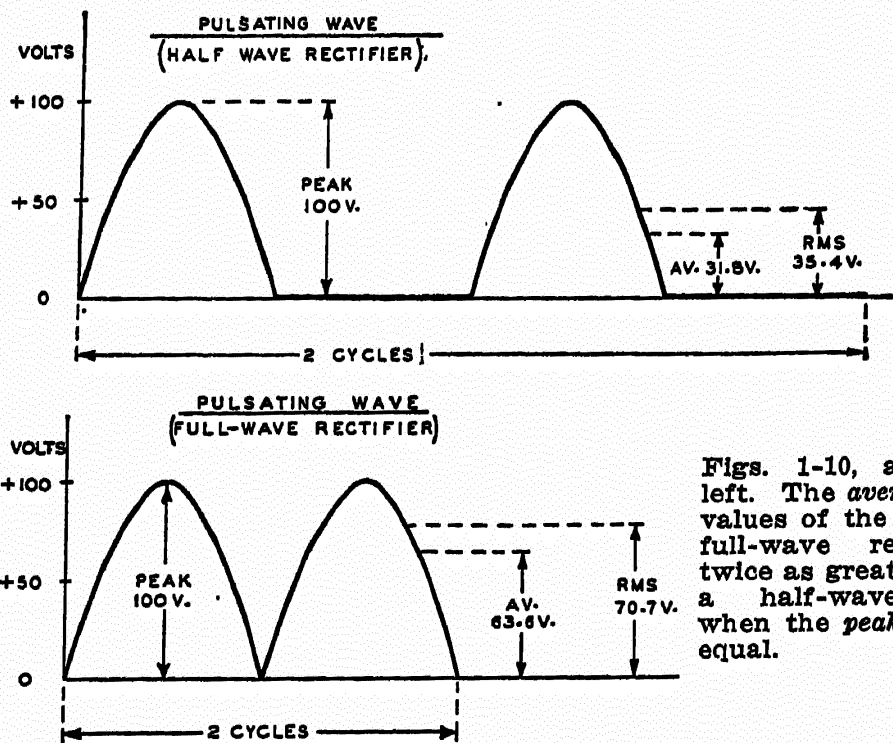

Figs. 1-10, above; 1-11, left. The *average* and *rms* values of the output of a full-wave rectifier are twice as great as those of a half-wave rectifier, when the *peak* values are equal.

reading of the d-c meter is the *average* value of this wave; if the waveform is undistorted, the reading will not change when the signal is removed because the average value of the wave is the same as the steady value of plate current.

Primarily we are interested in *average* values in this book because the indication of v-t voltmeters often depends upon the average value. For example, the v-t voltmeter described in connection with Fig. 1-4 is an "average-reading" v-t voltmeter. The reading of this milliammeter depends upon the average value of only the *positive* halves of the cycle. No current flows during the *negative* halves of the cycle, so that the reading of the meter is not influenced by the waveform of the negative half cycles. In this connection, if the tube were not biased to cutoff, the current flowing through the meter would be influenced by both the positive and negative halves of the cycle.

RMS Value—The *rms* or *root-mean-square* value is more often used

FUNDAMENTALS OF VACUUM TUBE VOLTMETERS II

in connection with a-c voltages and currents than either the average or peak values. Usually when we refer to a line voltage as being 117 volts, or a heater voltage as being 6.3 volts, it is the *rms* value which is designated. The rms value, often called the *effective* value, is a measure of the power in the current or voltage wave. It thus involves the aver-

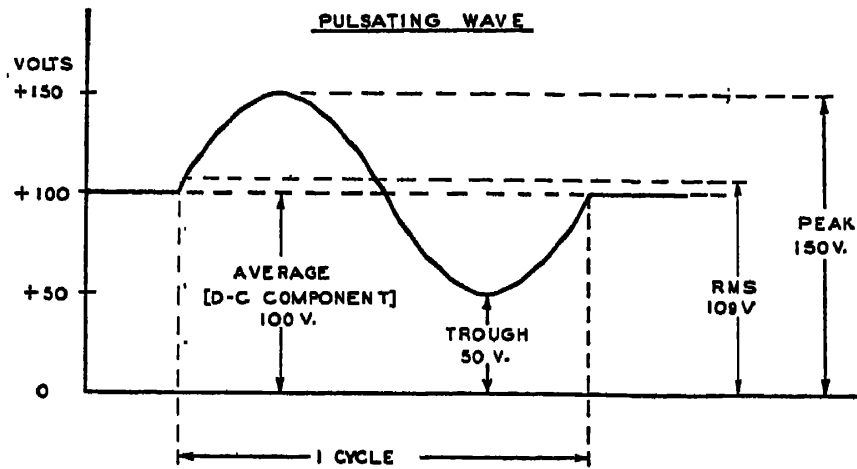

Fig. 1-12. The *peak*, *rms*, *average*, and *trough* voltages of a typical pulsating wave such as is found in the plate circuit of an amplifier tube. Note that the *average* value is equal to the d-c component of the wave.

age of the *squares* of all of the instantaneous values, for the same reason that the heating effect of a current is proportional to the square of the current.

In the case of a sine wave, the rms value turns out to be equal to 70.7% of the peak value of the wave, as is indicated in Fig. 1-5b. As in the case of the average value, the *rms* value is a different percentage of the peak value for different complex waves. An examination of Figs. 1-7, 1-8, and 1-9 will show how the rms value varies for different typical waveforms; these waveforms range from a triangular-shaped wave to the series of pulses used for synchronizing sweep circuits.

V-T Voltmeters Respond to Peak, Average, or RMS Values

Depending upon its design, the reading of a v-t voltmeter is a function of either the *peak* value, the *average* value, or the *rms* value (or some combination of these values) of the voltage applied to the input. As we have just seen there is no fixed relationship between these values, and so it is important to know just what type of v-t voltmeter one is using. The v-t voltmeter described in connection with Fig. 1-4 is an "average-reading" meter because its reading depends upon the *average* value of the positive half cycles. Other v-t voltmeters, which will be described later, are different from this meter in that their indication is proportional to the *peak* or the *rms* values.

Calibration of V-T Voltmeters—Vacuum-tube voltmeters are not always calibrated in terms of the value to which they respond. For example, it is very commonplace for commercial *peak-reading* v-t voltmeters to be calibrated so that the scale indicates the *rms* value of the input voltage. Whenever this is done, however, it is understood that this calibration holds true only for a sine wave in which the rms value is 70.7% of the peak value. If a v-t voltmeter of this type is used to measure the synchronizing pulse waveform in Fig. 1-9, for example, the instrument would respond to the peak value of 100 volts, and being calibrated in terms of a sine wave, would indicate 70.7 volts rms. The true rms value of this wave, however, is 37.8 volts, so that there is an error of 32.9 volts—an error of 87%!

Fortunately the voltages most frequently encountered are for the most part closely similar to a sine wave so that errors of the type mentioned above are the exception rather than the rule. However the preceding example emphasizes the fact that it is not sufficient to know that a vacuum-tube voltmeter is calibrated to read rms values. When working on voltages other than pure sine waves, that is, complex voltages, it is necessary to know whether the voltmeter is of the peak-reading type; whether it responds to the positive or negative peaks, or both; whether it is an rms type; and so forth. These considerations will be taken up in detail in the chapters where these meters are considered. In addition, a table of errors which may be encountered when working on complex voltages is given on page 150.

Balancing or “Bucking” Circuits

In the v-t voltmeters which have been described up to this point, the vacuum tube was operated at plate-current cutoff. As a result, no current flowed through the plate milliammeter (or microammeter) with no voltage applied to the input of the v-t voltmeter. In practice it is frequently very desirable to operate on a point of the vacuum-tube characteristic where the plate current has an appreciable value. In such instances the resulting no-signal plate current flow is a disadvantage because (1) the full meter scale cannot be utilized for measurement, and because (2) the sensitivity of the meter is limited to a value which is less than the no-signal plate current.

To permit the use of a more sensitive plate-current meter and to utilize the entire plate meter scale so as to increase the overall sensitivity of the v-t voltmeter, it is customary to balance or “buck” out the no-signal plate current. The methods for accomplishing this will be explained in detail in Chapter III. When a bucking circuit is used, the full scale of the meter is utilized for the calibration and the sensitivity of the meter may be as much as five or more times the no-signal plate current.

Chapter II

DIODE VACUUM-TUBE VOLTMETERS

ALTHOUGH many improvements have been made in vacuum tubes since the diode was invented, diode v-t voltmeters are still widely used today because of certain advantages which they afford. Apart from their own usefulness, they are of special interest because certain complicated v-t voltmeters also employ diode circuits; among these may be mentioned v-t voltmeters of the rectifier-amplifier, the amplifier-rectifier, and the logarithmic types. In this chapter we shall explain the operation of the diode rectifier since it is fundamental and necessary to an understanding of all diode v-t voltmeter circuits. In addition, we shall describe practical circuits of the various types of diode v-t voltmeters, including their operation and characteristics.

The Diode Characteristic

The property of the diode which makes it useful in v-t voltmeter circuits is its ability to conduct current in only one direction. When a positive voltage is applied to the plate of a diode, as Fig. 2-1a, b shows,

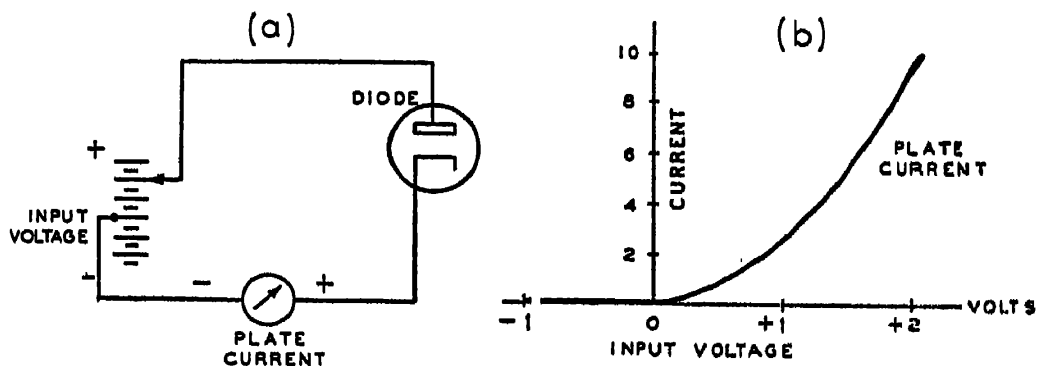

Fig. 2-1. A diode arranged so that positive and negative voltages can be applied to the plate is shown at (a). The plate-current characteristic at (b) shows that current flows only when the plate is made positive with respect to the cathode.

the resulting current increases as the plate voltage is increased. However, if the polarity of the voltage is changed so that the plate is made

negative with respect to the cathode, then no current flows. With zero plate voltage we assume the absence of plate current.¹

If you examine Fig. 2-1b, the plate voltage-plate current characteristic of the diode, you will note its non-linearity—the fact that there is no uniform relationship between the plate current and the plate voltage. The reason for this is that the resistance of the diode is not constant—it decreases for an increase in plate voltage.

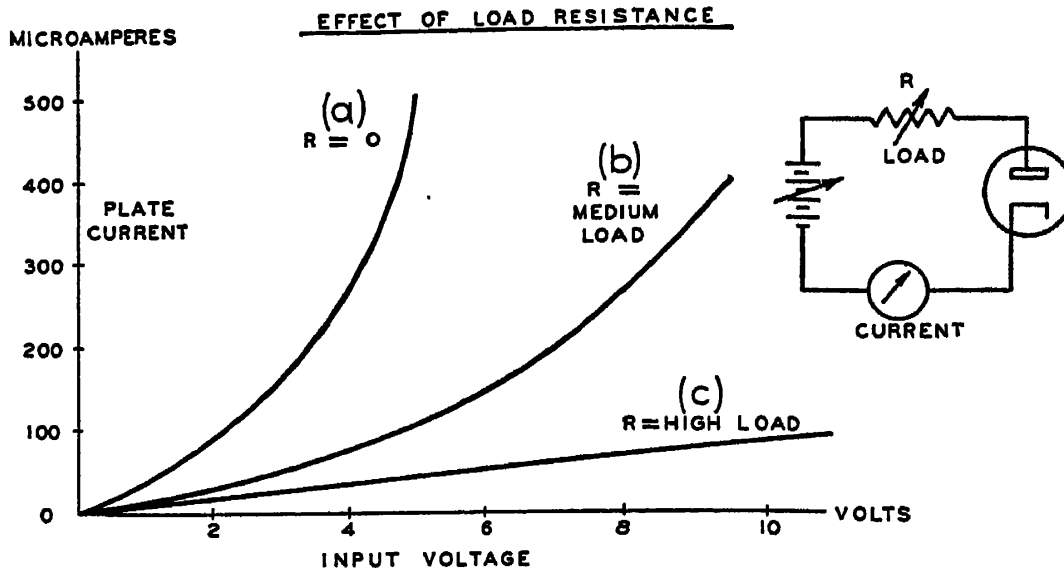

Fig. 2-2. The effect of load resistance on the plate current-plate voltage characteristic of a diode. A linear plate current variation can be secured by using a high value of load resistance as shown at (c).

However, it is possible by a very simple expedient to alter the characteristics of the diode circuit so as to nullify this variable resistance effect of the tube. This is done by the use of a load resistance, as shown in Fig. 2-2.

If a resistor is inserted in the diode circuit, the curved characteristic is straightened somewhat, as is shown by curve (b) in Fig. 2-2. If a still higher value of resistance is used, the characteristic becomes practically a straight line (c); however, the line is lowered appreciably because the current obtained for a given voltage is decreased by the load resistance. Note that the use of a high value of load resistance permits higher input voltages to be applied without excessive current being drawn by the diode.

The straightening effect of the load resistance demonstrated in Fig. 2-2 is a consequence of the fact that the non-linear diode resistance is small in comparison with the load resistance. Thus although the diode resistance itself varies with the applied voltage, these variations are

¹For a more complete description of the behavior of diodes with zero input voltage, see page 25.

negligible in comparison with the total constant resistance in the diode circuit.

In practice, values of load resistance above 100,000 ohms must be used to obtain a high enough value of input resistance when the diode rectifier is used as a v-t voltmeter. These values are sufficiently high so that the diode characteristic is essentially straight for values of input voltage above a few volts. A straight characteristic is desirable for two reasons: (1) the scale of the v-t voltmeter is then uniform and (2) the calibration becomes independent of variations in the resistance of the diode. Such variations may occur because of ageing of the tube or changes in the heater voltage.

Diode Rectifier Operation

The behavior of the diode when an a-c voltage is applied to the circuit is fundamental to an understanding of diode v-t voltmeters. In Fig. 2-3a we show a circuit in which an a-c voltage is applied to a diode

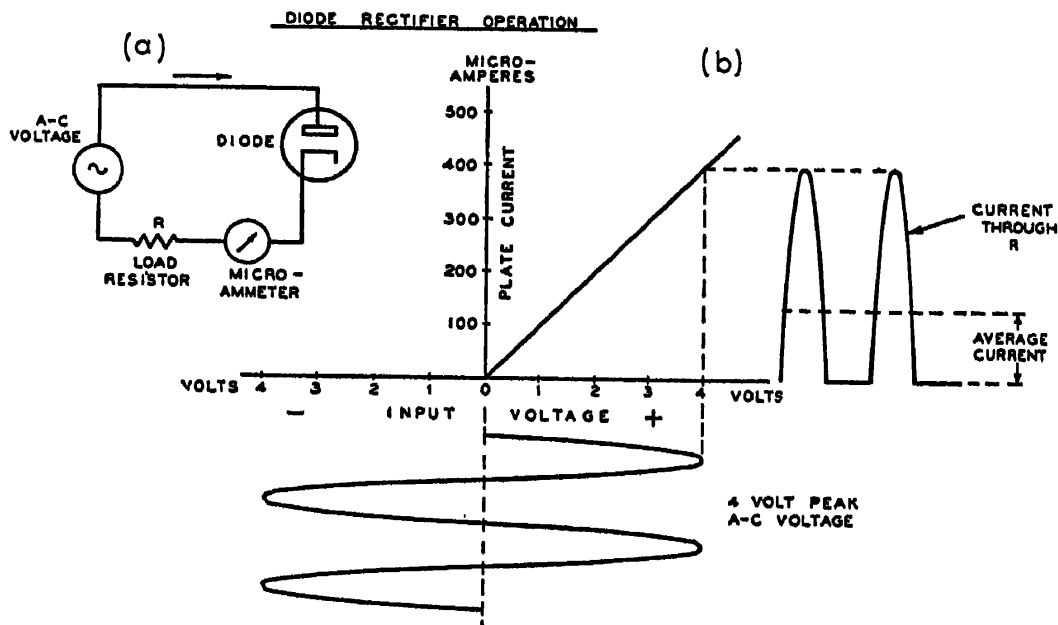

Fig. 2-3. The operation of a simple diode rectifier circuit. When an a-c voltage is applied to the plate, the positive half cycles are rectified and the d-c meter indicates the average value of the rectified plate current.

in series with a load resistor and a microammeter. To illustrate the action which takes place, we have shown at (b) the diode characteristic which was just described. For negative voltages we assume no current flow,¹ while for positive voltages the diode current increases uniformly as the applied voltage is increased.

¹ See page 25 concerning current flow with zero plate voltage.

The applied a-c voltage is shown below the voltage axis and consists of a sine wave of voltage which has a peak value of 4 volts. Starting with the positive half of the cycle, the plate current increases from zero to a maximum of 400 microamperes and then returns to zero as the voltage drops to zero. As the applied voltage goes through the negative half of the cycle, no current flows. The same action takes place on each of the succeeding cycles of applied voltage.

D-C Plate Microammeter Reads Average Value of Current—The current wave through R, the load resistor, shown in Fig. 2-3, is also the current through the d-c microammeter or milliammeter. Being a d-c meter, this instrument will not respond to the fluctuations in the rectified current but will respond only to the d-c component of the rectified current. This d-c component is precisely the same as the average value of the rectified current. It is indicated in the figure by the dotted line which shows that the reading of the d-c microammeter will be 31.8% of the peak value of the current.

D-C Current Is Proportional to Applied A-C Voltage—If we vary the a-c voltage applied to a diode rectifier, then the reading of the d-c meter will increase proportionately as the a-c voltage is increased. This is illustrated by the typical curve in Fig. 2-4, which shows that a 4-volt

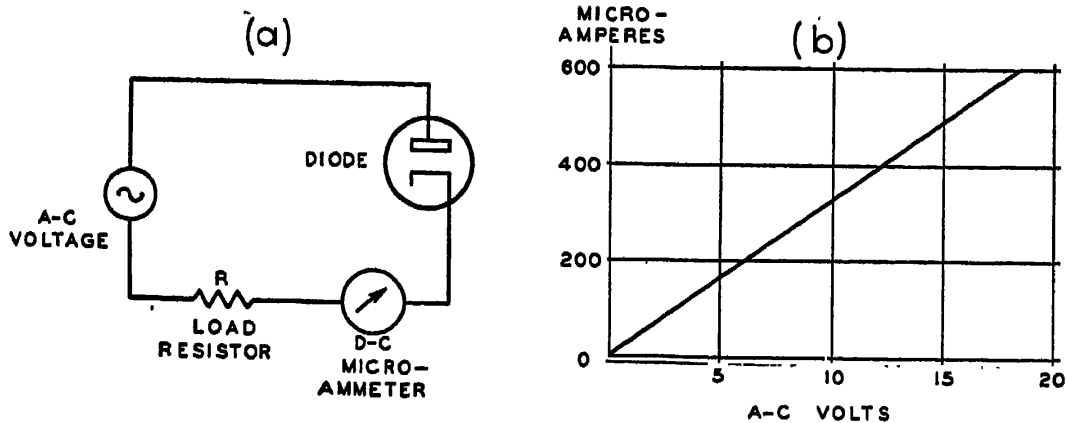

Fig. 2-4. When an a-c voltage is applied to a diode circuit, the rectified plate current increases as the applied a-c voltage is increased. A typical curve showing the relation between the d-c plate current and the applied a-c voltage appears at (b).

input will produce a d-c current of 130 microamperes, an 8-volt input will produce twice as much current, or 260 microamperes, etc. This curve shows that it is possible to calibrate the d-c microammeter in terms of the a-c input voltage, so that the diode circuit can be used as a v-t voltmeter. As can readily be seen by a study of Fig. 2-3, the reading of this type of v-t voltmeter depends upon the average value of the *positive half cycles* of the applied a-c voltage.

Simple Diode V-T Voltmeter

A v-t voltmeter using the circuit just described is shown in Fig. 2-5. This diode v-t voltmeter uses a 200-microampere meter, a 100,000-ohm load resistor and an ordinary receiving diode such as one section of a type 6H6 tube. When used for measuring a-c voltages it will give a full-scale deflection for an input voltage of some 45 volts rms. Although we mention the sensitivity of the voltmeter in terms of rms values, it is

Fig. 2-5. A simple diode v-t voltmeter in which a series resistor is used in order to raise the input resistance and obtain a linear response.

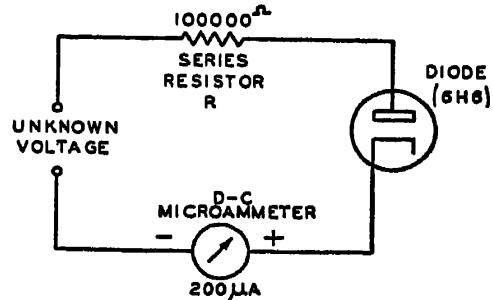

understood as previously explained that the meter reading is proportional to the *average* value of the positive half cycle of the wave being measured. This however, does not preclude calibration of the meter in rms values.

Input Resistance—The input resistance of this type voltmeter is equal to the value of the series or load resistor. In practice very high values of R cannot be used because of the resulting reduction in sensitivity. Thus if the input resistance were to be raised to 1 megohm, then a 20-microampere meter (instead of 200 microamperes) would be required in order to secure approximately the same sensitivity.

Frequency Response—The frequency response is limited to the lower radio frequencies because there will always be some shunt capacitance which will tend to bypass the r-f currents around the series resistor, R . This will make the meter read high as the frequency is increased, since a larger current will flow through the meter than if the current were completely limited by the series resistor, R . In general the higher the value of R , the more limited will be the frequency response.

Limited Application—Because of its comparatively low input resistance and limited frequency range, the “series-resistor” type of diode v-t voltmeter has a very limited use. Other diode v-t voltmeters which are superior to this circuit for practically all applications will be described in this chapter.

Peak Diode V-T Voltmeter—Series Type

The v-t voltmeter circuit shown in Fig. 2-6 will be recognized as similar to the familiar diode detector circuit used in superheterodyne radio receivers. In this circuit a bypass condenser is used across the load resistor. The effect of this condenser is to make the circuit respond

to the *peak* value of the positive half cycle of the applied a-c voltage. If the condenser is removed, then the circuit becomes similar to Fig. 2-5, and it then responds to the *average* rather than the *peak* value.

Operation—As in all diode circuits, no current flows through the diode on the negative half of the cycle. On the positive half, however, the plate becomes positive with respect to the cathode so that electrons flow into the plate end of condenser *C* and out of the cathode end. The result of this action is to charge *C* to a voltage which is only slightly less than the peak value of the applied voltage.

To take a definite example, let us assume that a 100-volt peak a-c voltage is being measured. On the positive peak of the signal, *C* will charge up to 100 volts. Because of the shunt resistor across the con-

SERIES TYPE PEAK V-T VOLTMETER

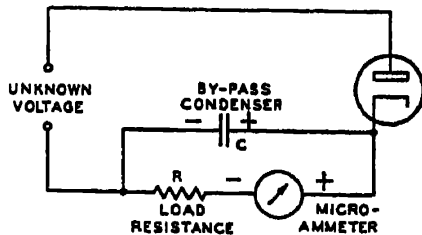
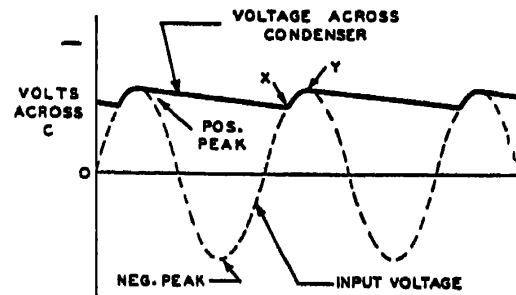

Fig. 2-7, right. The shunt condenser *C* (above) becomes charged negatively by an amount equal to the positive peak of the applied voltage. During the interval between positive peaks, *C* discharges slowly as indicated by the sloping solid line.

Fig. 2-6, left. A diode v-t voltmeter in which a peak response is obtained by shunting the load resistance *R* with a large condenser *C*.



denser, however, the condenser will at all times be slowly discharging through the resistor. The effect of this action is to make the voltage across *C* drop from about 100 volts to about 95 volts during the time between positive peaks of the applied voltage.

The manner in which the voltage across *C* varies is shown in Fig. 2-7. From a study of this figure it is apparent that current flows in the diode circuit only for the small interval *XY* near the positive peak of the applied voltage. Throughout the remainder of the cycle the charge on *C* keeps the plate negative with respect to the cathode so that the diode is non-conducting. When *R* and *C* have the proper value, however, the amount of charge which is replenished while the diode is conducting is sufficient to compensate for the slow discharge of the condenser through *R* and the meter. For proper operation the time constant of the circuit ($R \times C$) should be large in comparison with the time of 1 cycle. Typical values of *R* and *C* for different frequency ranges are given in the table on page 24.

Sensitivity—The sensitivity of the series-type peak v-t voltmeter is

limited by the value of the load resistance and the sensitivity of the d-c microammeter or milliammeter. Since C charges to the peak value of the input voltage, the average current through the meter will be equal approximately to the peak input voltage divided by the resistance of R . Thus if R has a value of 1 megohm, full-scale deflection on a 100-microampere meter will be obtained for a peak input voltage of slightly more than 100 volts.

Input Resistance—The input resistance depends upon the value of R and is approximately equal to one-half the resistance of R . The input capacitance depends upon the capacitance of the diode and the leads, and is not affected by the large value of capacitance used for C . The reason that C does not shunt the input of the v-t voltmeter is because C is isolated from the input circuit by the diode *which does not conduct current except for a small fraction of the cycle on the very peak of the input voltage.*

Frequency Error—The series-type peak v-t voltmeter has a negligible frequency error over a range extending as high as 50 megacycles. Unless the proper values of R and C are used, however, the calibration will not be the same for all frequencies. The values of R and C which must be used to obtain peak action are described on page 24.

D-C Path Is Required—This type of v-t voltmeter, as well as that shown in Fig. 2-5, cannot be used for measurements unless a complete d-c path is present for charging the condenser C . For example, it cannot be coupled to another circuit through a blocking condenser since there would then be no complete d-c path in the diode circuit. When this type of circuit is used as a detector, a complete d-c path is always present through the secondary winding of the r-f or i-f transformer. When it is necessary to measure a-c voltages in a circuit where a d-c component must be blocked off, it is preferable to use the diode circuit shown in Fig. 2-8.

Peak Diode Voltmeter—Shunt Type

One of the most useful of the diode v-t voltmeter circuits is the shunt-type circuit illustrated in Fig. 2-8. With this circuit the voltage to be measured is coupled to the diode by means of a condenser C which also blocks any d-c voltage that may be present. The performance of this circuit is generally similar to that of the series-type peak v-t voltmeter (Fig. 2-6), although the arrangement of components is different.

Operation—When an a-c voltage or signal is applied to the input terminals, the diode draws current on the positive peaks. As a result of this action, condenser C becomes charged, with the polarity indicated in Fig. 2-8, to a voltage which is almost equal to the positive peak of the signal. The plate of the diode is thus maintained at a d-c voltage equal to the peak value of the signal, so that a steady d-c current flows

through the meter. The value of this current is equal to the peak signal voltage divided by the resistance of R .

A diagram of the current flowing through the diode is shown in Fig. 2-9. As this figure shows, the diode is non-conducting except for a brief interval near the positive peak of the applied voltage. At this point there is a surge of current, and this, averaged over the entire cycle, provides the d-c current which actuates the meter.

Although the meter is shown in series with the load resistor R , it is also possible to place it in series with the cathode of the diode. In this connection it is worth noting that the d-c current measured by the meter circulates around the resistor and diode and thus has the same

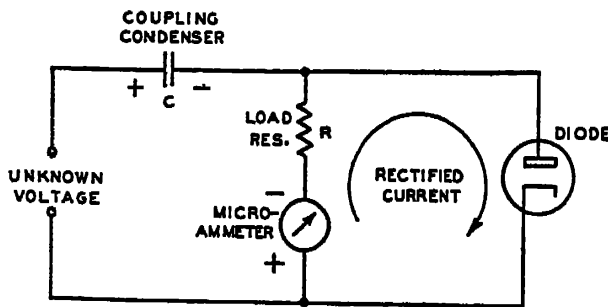
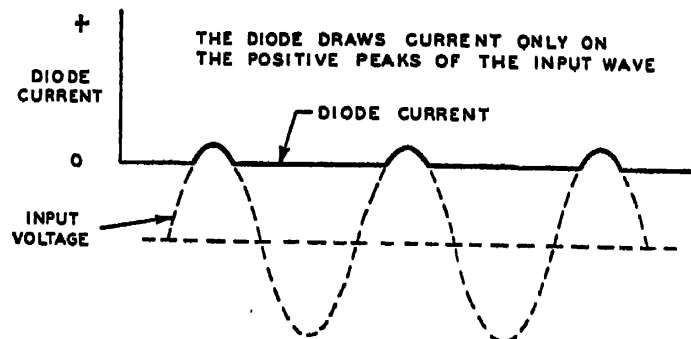

Fig. 2-8, left. A diode v-t voltmeter in which the unknown a-c voltage is coupled to the diode circuit through a blocking condenser C . The rectified current circulates through the diode, meter, and R as indicated by the arrow.

Fig. 2-9, right. In the circuit shown above, a pulse of current is drawn by the diode on each of the positive peaks of the input voltage. The reading of the d-c meter is equal to the average value of these current pulses.



value in either the resistor leg or the diode leg. It is preferable to insert the meter in series with the resistor, since the r-f current through the meter is then smaller than if the meter were placed in series with the cathode leg of the circuit.

Loading—The loading of this type of diode v-t voltmeter is determined by R and is equal approximately to one-half the resistance of R . For this reason it is desirable to keep R as high as is possible. The limiting factor is the required sensitivity which is reduced as R is increased.

Frequency Error—The shunt-type peak v-t voltmeter has a negligible frequency error provided that the correct values of R and C are used so as to obtain peak response over the complete frequency range. The values of R and C which must be used for different frequency ranges are shown on page 24.

Sensitivity—The sensitivity is determined by the resistance of R and the sensitivity of the d-c microammeter or milliammeter. The peak voltage required for full-scale deflection can be determined by multiplying the full-scale current by the load resistance. For example, if R is 1 megohm, and a 100-microampere meter is used, then slightly more than 100 volts peak is required for full-scale deflection. The sensitivity can be increased by either lowering R or using a more sensitive meter. Either one of these alternatives is undesirable because the one reduces the input resistance, while the other raises the cost. A more practical alternative is to amplify the output of the diode. Rectifier-amplifier v-t voltmeters are widely used; they are described in Chapter V.

Linearity—The calibration of the shunt-type peak v-t voltmeter, like that of all diode voltmeters, is usually linear for voltage ranges higher than several volts. On the low-voltage ranges, however, a non-linearity is introduced because of imperfect rectification.

D-C Path Is Not Required—Unlike the series-type v-t voltmeter, no direct-current path is required with the shunt-type v-t voltmeter. This is apparent from the fact that the rectified current circulates through the load resistance R and the diode, so that an external path through the circuit being measured is not required. This is an important advantage of the shunt-type circuit, as is also the fact that the condenser C blocks any d-c voltage which may be present. The blocking action of the input condenser is often a great advantage since there are many occasions where a small r-f voltage must be measured at points where a large d-c voltage is present. A typical example of such a case is the problem of measuring the signal voltage at the plate of an amplifier tube. In this instance C permits only the signal (the a-c component of the voltage at the plate) to reach the rectifier circuit.

A Shunt-Type Diode Voltmeter Circuit

A practical shunt-type diode peak v-t voltmeter circuit using a 6H6 diode rectifier is shown in Fig. 2-10a. As the calibration curve of Fig. 2-10b shows, the range covered with the constants shown is 50 volts for full-scale deflection on a 100-microampere meter. The input resistance is approximately half the load resistance or about 250,000 ohms.

If it is desired to keep the input capacitance as low as possible, the 6H6 can be replaced with a triode which has the control grid connected to the top cap. A triode which has unusually low input capacitance is the type 85 or its equivalent. All the elements except the control grid are tied to the cathode in this application, so that the triode actually functions as a diode. Where voltages up to several hundred volts are to be measured, a type 1-V or 6X5-GT rectifier tube can be used.

Although greater sensitivity can be obtained by decreasing R or by using a more sensitive meter, it is more desirable where greater sensi-

tivity is required to use either a triode or a rectifier-amplifier type v-t voltmeter. Both of these types are described in subsequent chapters.

As mentioned in Chapter I, it is possible to calibrate a *peak* v-t voltmeter in terms of *rms* values by multiplying each one of the peak values

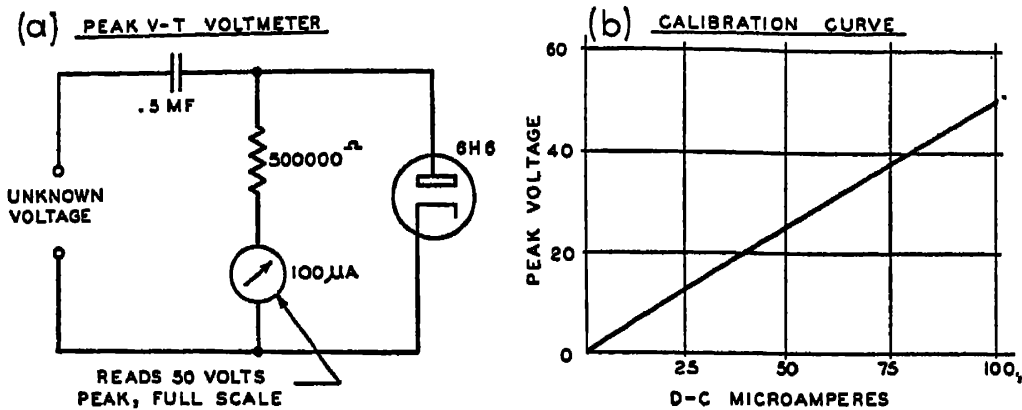

Fig. 2-10. A simple peak v-t voltmeter using a 6H6 diode. An approximate calibration for this v-t voltmeter is shown at (b).

shown in the calibration curve at (b) by 0.707. Although the scale can be calibrated in rms values in this manner, the indication is not a true rms reading and is accurate only for a sine wave of voltage.

A High-Voltage Shunt-Type Peak V-T Voltmeter

A diode v-t voltmeter suitable for the measurement of high values of a-c voltage is shown in Fig. 2-11. The circuit is the same as the preceding one with the exception that the type 6H6 tube has been replaced by a television high-voltage rectifier tube of the 2X2 type. This latter tube, although its envelope is no larger than that of an ordinary receiving tube, is rated to withstand peak voltages up to 6700 volts and has a low input capacitance because of the large separation between the plate and cathode. With the constants shown, full-scale deflection is obtained on the 500-microampere meter when a peak voltage somewhat greater than 5000 volts is applied. The calibration curve on this range is very nearly linear, although for lower voltage ranges the calibration is curved slightly because of the comparatively high internal resistance of the diode. This high internal resistance is due to the large separation between the cathode and plate.

The type 2X2 rectifier tube is especially desirable for v-t voltmeter application because it is of the cathode type. Where a filament-type diode is used, a current reading will be obtained even when no external voltage is applied. This is because part of the filament voltage is effective in maintaining a difference in potential between the filament and the plate and thus causes rectification to take place. This effect is not

important unless voltages less than 100 volts are to be measured. This effect should not be confused with the "contact-potential" effect which is described on page 25.

The coupling condenser should be rated to withstand twice the highest peak voltage to be measured. Similarly the load resistor should be capable of withstanding this same value of voltage. A special high-voltage resistor can be used or several low-voltage resistors can be placed in series in order to obtain the required rating. The meter and filament transformer are at the low-potential side of the input circuit so that no special precautions are required, *provided the low side of the input is always connected to ground.*

By varying either the load resistance or the sensitivity of the meter, it is possible to obtain other voltage ranges such as 1000 volts full scale. For voltages below several hundred volts it is preferable to use a receiv-

Fig. 2-11. A diode v-t voltmeter suitable for the measurement of high values of a-c voltage. A type 2X2 high-voltage rectifier tube is used.

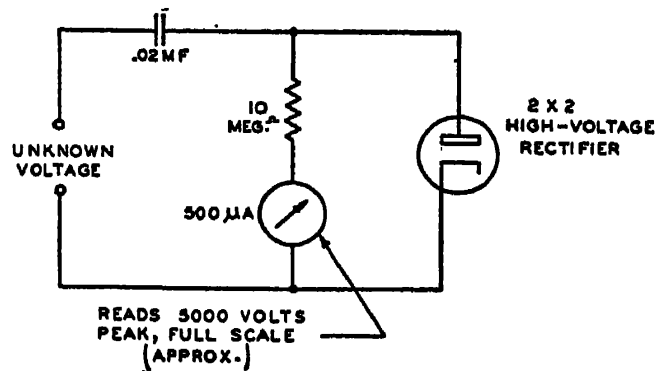

ing-type diode so as to obtain a more linear calibration. A receiving-type diode is preferable because it has a lower internal resistance than a high-voltage diode.

In the case of high-voltage diode v-t voltmeters it is especially desirable to run a calibration curve and not to rely on the computed calibration. If this procedure is not followed there will be an appreciable error because the high internal resistance of the diode prevents the condenser from charging up to the full peak value of the applied voltage.

Values of R and C for Peak V-T Voltmeters

The operation of both the series and shunt type of peak v-t voltmeter depends upon the choice of proper values of R and C . The criterion to be followed in picking suitable values for R and C is that the *time constant* of the R - C combination must be large in comparison with the time of one cycle. The *time constant* is a measure of the time required for a condenser to charge or discharge through a resistor; specifically, it is the time required to charge a condenser to 63% of its final voltage, or the time required for it to lose 37% of its initial voltage. To obtain the time constant in seconds, multiply the value of R in megohms by

the value of C in *microfarads*. For example, the time constant of a 2-megohm resistor and a 0.5-mf condenser is $2 \times 0.5 = 1$ second.

A useful rule is that the time constant RC of a peak v-t voltmeter should be equal to about $100 \times 1/f$, where f is the lowest frequency to be measured. Since $1/f$ is the time of one cycle, this is only another way of stating that R and C should be large enough so that their product is at least one hundred times the duration of 1 cycle of the lowest frequency. Another way of expressing this same relationship is by the equation $RCf = 100$.

Typical values of R and C for different frequency ranges is given in the table of Fig. 2-12. If it is desired to cover down to about 25 cycles, the action of the meter will become very sluggish because the condenser takes an appreciable time to change its voltage when the applied voltage is changed. For this reason it is often preferable to use a medium value of C for all r-f and a-f work. When it is necessary to measure low-frequency voltages, an additional condenser of 1 mf or more can be connected in shunt with the internal condenser. The regular calibration will then apply to 25 and 60 cycles, as well as to the higher frequencies.

FIG. 2-12. R AND C VALUES FOR PEAK V-T VOLTMETERS

| Frequency | R C | Typical Values of R-C * | |
|----------------------|---------|-------------------------|------------------|
| | | R Megohms | C Microfarads |
| above 25 cycles | 4 | 1 | 4 |
| above 60 cycles | 1.7 | 1 | 2 |
| above 1000 cycles | 0.1 | 1 | .1 |
| above 100 kc | 0.001 | 0.1 | .01 |
| above 10 mc | 0.00001 | 0.1 | .00005 |

* For any frequency range, different values of R and C can be used provided that the product RC is not less than the value specified in the RC column. ($RC = 100/f$).

“Contact Potential” Effect in Diode V-T Voltmeters

In the preceding description of diode v-t voltmeters we deferred a discussion of the action taking place when small voltages are measured by means of a diode rectifier. This action is complicated by the fact that the initial speed with which the electrons leave the cathode is sufficient to carry them to the plate even when no external voltage is applied. And even when the circuit is incomplete, the speed with which the electrons arrive at the plate is sufficiently great so that the plate assumes a potential or voltage which is about 1 volt negative with respect to the cathode. Both of these interrelated effects will now be described.

Zero-Signal Current—When the plate and cathode of a diode are connected together through a resistor, Fig 2-13a, it is found that a small

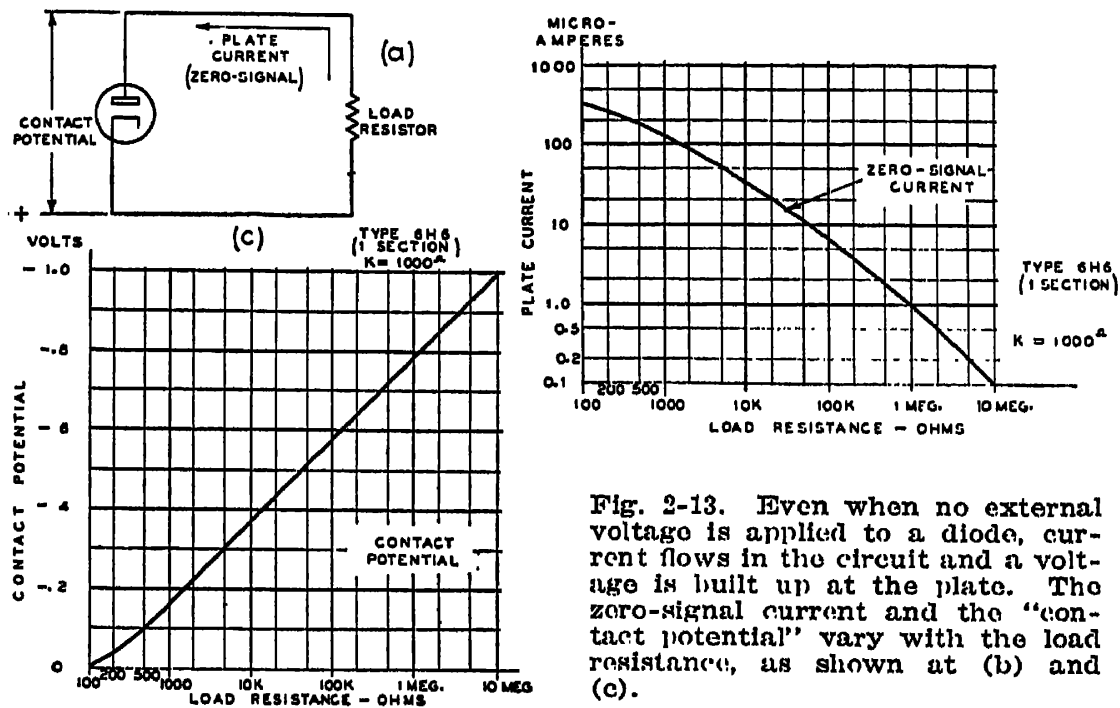

Fig. 2-13. Even when no external voltage is applied to a diode, current flows in the circuit and a voltage is built up at the plate. The zero-signal current and the “contact potential” vary with the load resistance, as shown at (b) and (c).

current flows because of the high speed with which many of the electrons leave the cathode. (The arrow is shown toward the plate because the conventional direction of current flow is taken to be opposite to the direction of electron flow.) For the type 6H6 diode, a current of about 300 microamperes flows when the plate and cathode are connected together directly; the exact current depends to a great degree upon the heater voltage and the condition of the cathode.

The manner in which this zero-signal current varies as the load resistance is increased is shown in Fig. 2-13b. Starting with a resistance value of 100 ohms, the curve shows that the current decreases from about 300 microamperes for a resistance of 100 ohms, to about 0.1 microampere for a resistance of 10 megohms.

When a diode rectifier is used in a v-t voltmeter circuit, a current will thus flow even when no voltage is applied; the magnitude of the current which can be expected is given by the curve at (b). In high-range v-t voltmeters this initial or zero-signal current is ordinarily so small that it is negligible. However, in low-range diode v-t voltmeters, it is necessary either to balance out the initial current or to make allowance for it in some other way.

“Contact” or Zero-Signal Potential—Depending upon the value of load resistance connected to a diode, the zero-signal plate current will cause a voltage drop to take place between the cathode and the plate. This drop is in such a direction as to make the plate negative with respect to the cathode. This effect is illustrated by the curve shown in Fig. 2-13c. For values of load resistance less than about 100 ohms the contact potential is effectively short-circuited, so that the voltage difference between plate and cathode is reduced to practically zero. As the load resistance is increased, however, the plate becomes steadily more negative until it reaches a potential of about 1 volt negative with a load resistor of about 10 megohms. For still higher values of load resistance, the potential at the plate becomes only slightly more negative than the 1-volt value for a 10-megohm load.

With the circuits which have been thus far described, the zero-signal current is of greater interest than the contact potential. Later, however, we shall describe rectifier-amplifier types of v-t voltmeters in which the voltage developed at the plate is taken as a measure of the input voltage. In this type of v-t voltmeter, the zero-signal voltage or contact-potential curve is of primary interest.

The curves which we have shown are for the representative 6H6 receiving-type diode. Other tubes, such as triodes used as diodes, also show the same effect. In high-voltage diodes, such as those of the 2X2 type, the same effect is present but to a much smaller degree. Thus in the type 2X2, the zero-signal current with zero load resistance is only about 0.1 microampere as against 300 microamperes for the type 6H6. This tremendous difference is due to the much wider spacing between the cathode and plate in the high-voltage diode. Although the zero-signal current of high-voltage rectifiers is much smaller, the contact potential is still appreciably large because of the high diode resistance. Thus the contact potential of the type 2X2 is about 0.4 volt as against about 1 volt for the type 6H6.

Effect on Calibration—The effect which we have been describing is of greatest importance only on the low-voltage ranges of diode v-t voltmeters. On ranges less than about 10 volts, the zero-signal current can be bucked out or balanced out by using circuits similar to those described on page 55. Even though this initial current is balanced out, however, the calibration will not be linear for inputs of less than several volts because of the high internal resistance of the diode.

Slide-Back Diode V-T Voltmeter for Positive Peak Voltages

The v-t voltmeters which have been described up to this point have all been of the direct-reading type. By this statement it is meant that an unknown voltage applied to the input terminals, can be read directly on the meter scale. In contrast to this type of v-t voltmeter, there are other types which are not direct reading but which require a balancing adjustment to be made before the unknown voltage can be determined. A simple diode v-t voltmeter of this type is shown in Fig. 2-14; it is known as a *slide-back* diode voltmeter. The reason for its name will be clear from the following description of its operation.

To measure a voltage with the diode voltmeter shown in Fig. 2-14, the potentiometer R is first adjusted so that the slide-back voltmeter

Fig. 2-14. A slide-back diode v-t voltmeter which can be used for the measurement of positive peak voltages. The voltage V required to restore the initial plate current is equal to the positive peak voltage.

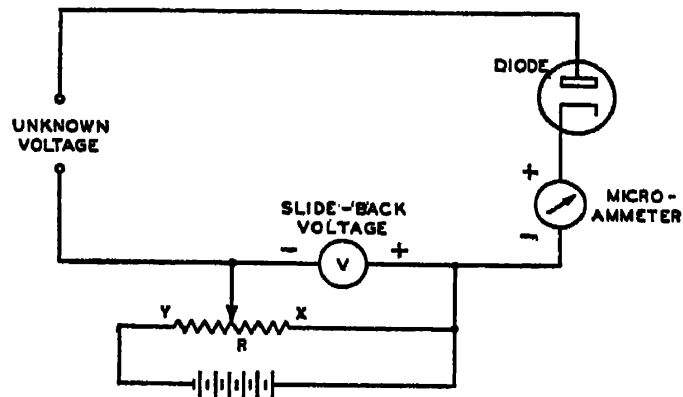

reads zero. Under this condition the tap on the potentiometer will be at point X and a small current reading will be obtained on the microammeter as a result of the high speed with which the electrons leave the cathode. To check this initial reference current, the input terminals of the v-t voltmeter should be connected together so as to provide a d-c path.

The unknown voltage is then applied to the input terminals. Rectification of the positive peaks of this voltage will take place, so that the current through the microammeter will increase appreciably from its previous no-signal value. If, however, the slideback voltage is increased so as to make the plate more negative, the current will gradually decrease until finally the current is reduced to its initial value. Under this condition, as Fig. 2-15a clearly shows, the positive peak of the unknown voltage is equal to the slide-back voltage indicated by the voltmeter V in Fig. 2-14. The conditions existing when the slide-back voltage is too small and too large are shown at (b) and (c) of Fig. 2-15. If the slide-back voltage is too small as at (b), then rectification of the positive peaks takes place and the microammeter will indicate a large current flow. On the other hand, if the slide-back voltage is too great

as at (c), then the diode plate will be biased so negatively that no plate current will flow during any part of the cycle. The proper setting of the potentiometer is obtained, as shown at (a), when the slide-back voltage is just about equal to the positive peak voltage being measured.

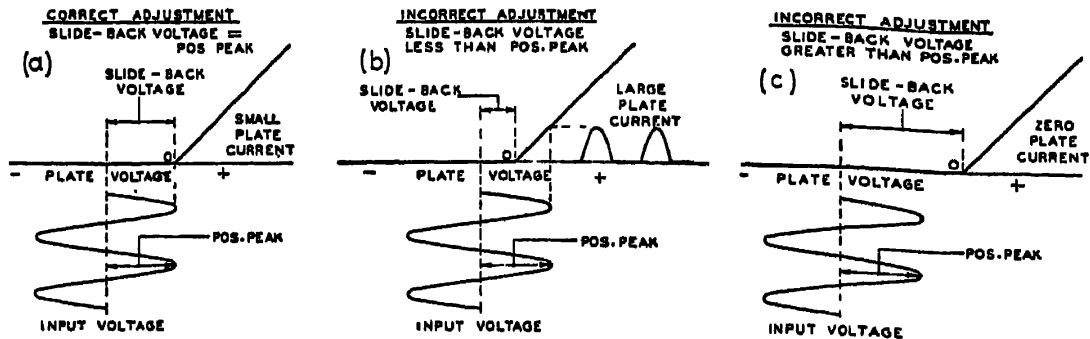

Fig. 2-15. These figures illustrate correct and incorrect adjustments of the slide-back voltage. The slide-back voltage is equal to the peak voltage when the initial small reference value of plate current is restored.

Use of Bias Voltage—Greater accuracy can be obtained if a small negative voltage is placed in series with the slide-back voltage, as shown in Fig. 2-16. This voltage enables the plate current to be reduced to a few microamperes, which is considerably less than the usual zero-signal current of about 300 microamperes.

To use this circuit, $R1$ should be set so that the slide-back voltmeter V reads zero. With the input terminals shorted, the zero adjustment $R2$ should be set so that some definite small value of current is indicated by the microammeter; a suitable value is about 10 microamperes, and this will usually require a biasing voltage of about 0.5 volt negative. As before, the positive peak signal voltage is equal to the slide-back voltage required to reduce the plate current to its initial value—in this case 10 microamperes.

Of course this same method of providing an initial bias can also be used with the circuit shown in Fig. 2-14, since the bias can be provided by adjusting R to a suitable point near X . However, in this instance the bias voltage will also be read by the slide-back voltmeter, so that the bias voltage must be subtracted from the reading of V to obtain the peak voltage.

Accuracy—If the slide-back diode voltmeter is used to measure a-c voltages smaller than about 10 volts, a direct calibration must be made. For small voltages, the slide-back voltage is not accurately equal to the peak value of the signal because the “tip” of the positive peak must be rectified before the small initial value of current is obtained. The effect of this is to introduce an error which makes the slide-back voltage somewhat smaller than the actual positive peak being measured. The amount of this error is of the order of 0.5 volt so that usually it can be neglected only when voltages larger than about 10 volts are being measured.

D-C Path Required—The slide-back diode voltmeter cannot be used unless the source being measured provides a complete d-c path through which the rectified current indicated by the meter can flow. To obtain the greatest accuracy, the d-c resistance when the zero adjustment is made should be of the same order as the resistance looking into the voltage being measured.

Where the source being measured does not provide a complete path for the rectified current, the shunt-type circuit shown in Fig. 2-8 can be employed. This circuit has a self-contained d-c path and in addition incorporates a blocking condenser so that d-c voltages will not affect the reading.

Positive Peak Is Measured—It is clear from the preceding description that the circuits in Figs. 2-14 and 2-16 respond to the positive peak of the applied voltage. The somewhat similar circuits described in the

Fig. 2-16. The zero adjustment voltage, controlled by R2, makes it possible to reduce the plate current to a small reference value. When the reference current is restored, the slide-back voltmeter V indicates the positive peak directly.

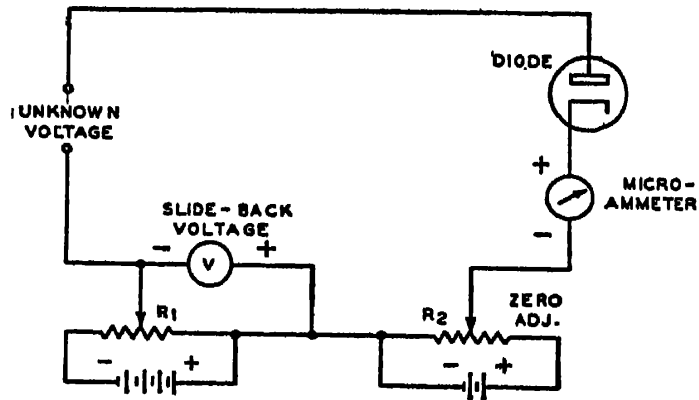

following sections enable the measurement of the negative peak of an a-c wave and the *trough* voltage of a pulsating wave.

Avoiding Injury to Meter—To avoid excessive current through the plate microammeter, it is desirable to apply a large negative slide-back voltage to the plate before the unknown voltage is applied to the input terminals. The slide-back voltage can then be reduced until the initial value of plate current is indicated by the microammeter.

Slide-Back Diode V-T Voltmeter for Negative Peak Voltages

By reversing the connections to the cathode and plate of the diode, the slide-back voltmeter shown in Fig. 2-16 can be converted into an instrument for the measurement of negative peak voltages. The modified circuit is illustrated in Fig. 2-17a. Note particularly that the polarity of the slide-back voltage is still such that it enables the plate to be made negative with respect to the cathode, although apparently the polarity of the slide-back voltage has been reversed.

To make a voltage measurement of the negative peak, the input terminals are first connected together and the initial bias adjusted so that

the plate current is 10 microamperes or some other suitable low value which can be read on the meter. The potentiometer is then set at *Y*, so that the maximum positive slide-back voltage is applied to the cathode. The unknown voltage is applied to the input terminals, and the slide-back voltage reduced until the initial plate current reading of 10 microamperes is again obtained. As Fig. 2-17b shows, under this condition

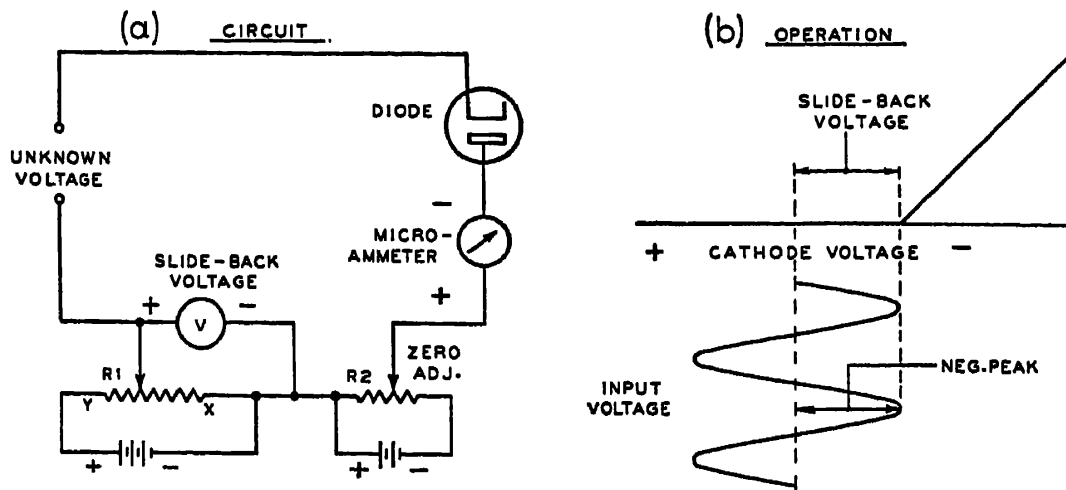

Fig. 2-17. By reversing the cathode and plate, it is possible to measure negative peak voltages. Operation of the circuit is illustrated at (b), which shows the plate current variation in terms of the *cathode* voltage. Note carefully the polarity of the slide-back and zero-adjustment voltages.

the slide-back voltage will be equal to the negative peak of the applied signal.

The various considerations explained in connection with slide-back voltmeters for positive peak voltage measurements also apply to this circuit.

In those instances where the voltage being measured is isolated from ground, either the positive peak circuit (Fig. 2-16) or the negative peak circuit (Fig. 2-17) can be used for the measurement of both positive and negative peaks. This can be done simply by reversing the connections to the input terminals of the v-t voltmeter. However, this procedure should not be attempted when one side of the voltage being measured is grounded.

Slide-Back Diode V-T Voltmeter for Trough Voltages

By reversing the polarity of the slide-back voltage, Fig. 2-18, the negative peak voltmeter just described can be used to measure the *trough voltage* in a pulsating wave. As Fig. 2-19a shows, the trough voltage of a pulsating wave is *the lowest value to which the voltage drops during the cycle*. A voltage wave of this type is obtained at the plate of an amplifier tube when an a-c signal is applied to the grid. In

a typical instance, the voltage at the plate might fluctuate between say 250 volts and 50 volts; the trough voltage would then be 50 volts.

To measure the trough voltage, the zero adjustment is made so that the plate current reads about 10 microamperes. The unknown voltage

Fig. 2-18. A slide-back diode v-t voltmeter arranged so as to measure the trough voltage of a pulsating wave. Note the polarity of the various voltages. The operation of this circuit is shown in Fig. 2-19 below.

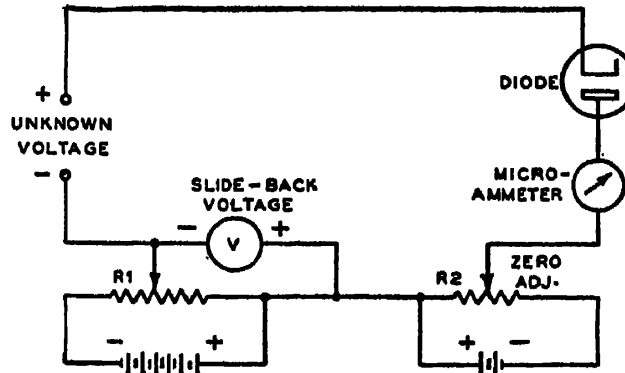

is then applied to the input terminals, the connections being made so that the positive side is applied to the cathode terminal. The effect of the unknown voltage is thus to bias the diode so that the plate current is completely cut off. If now the slide-back voltage is increased until the initial value of plate current is obtained, then the slide-back voltage

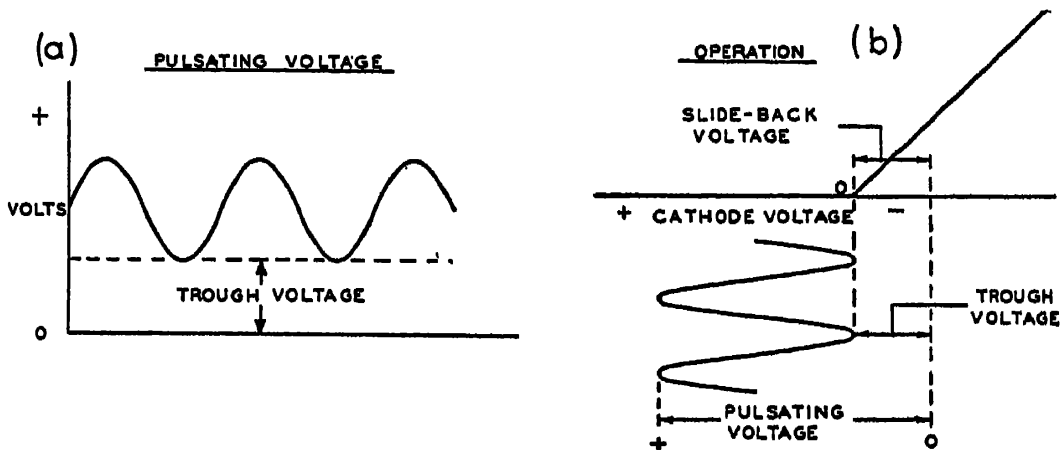

Fig. 2-19. When a pulsating voltage (a) is applied to the voltmeter in Fig. 2-18 above, the slide-back voltmeter will indicate the trough voltage of the wave, as shown at (b). The diode characteristic is shown in terms of the cathode voltage for simplicity.

will be equal to the trough value of the pulsating voltage as is clear from a study of Fig. 2-19.

Note that in this circuit the effect of increasing the slide-back voltage is to cause the plate current to *increase*. To avoid overloading the meter, the unknown voltage should be applied before the slide-back voltage is increased. This, of course, is the reverse of the usual procedure with slide-back voltmeters.

Chapter III

TRIODE VACUUM-TUBE VOLTMETERS

THE primary advantages of the triode v-t voltmeter are its almost infinite input resistance and its relatively high sensitivity. Both of these advantages result because a negligible amount of power delivered to the control grid of a triode is capable of controlling a comparatively large amount of power supplied by the triode plate battery. Thus when a signal is applied to the control grid of a negatively-biased triode, the plate current is varied without any current being drawn by the control grid. We may contrast this with the diode v-t voltmeter where the power required for the measurement must be supplied from the circuit being measured, rather than from an auxiliary battery. Although the triode v-t voltmeter requires a larger number of components, including bias and plate voltage supplies, its higher input resistance and greater sensitivity more than compensate for its greater complexity.

We are limiting the discussion in this chapter to direct-reading triode v-t voltmeters for a-c voltage measurements. Other types of triode v-t voltmeters will be described in subsequent chapters.

Like all v-t voltmeters, the triode v-t voltmeter is essentially a detector although it is not always used that way, and just as there are many types of detectors, so there are many types of triode v-t voltmeters. The plate detector, the grid detector, the linear detector, etc., all have their counterparts in v-t voltmeters which are based on similar operating principles.

Plate Detection V-T Voltmeters

The plate current-grid voltage curve shown in Fig. 3-1 is typical of triode vacuum tubes. Vacuum-tube voltmeters which utilize this characteristic are called *plate detection* or *plate rectification* v-t voltmeters and depend for their operation on the fact that the unknown voltage applied to the grid causes an increase in plate current on the positive half cycle which is greater than the decrease on the negative half cycle. As a result, a net increase in plate current takes place and this increase is a measure of the unknown voltage applied to the grid. Voltmeters

of this type are referred to as being of the *peak*, *half-wave*, or *full-wave* types—depending upon whether the operating bias is greater than cut-off, at cut-off, or less than cut-off.

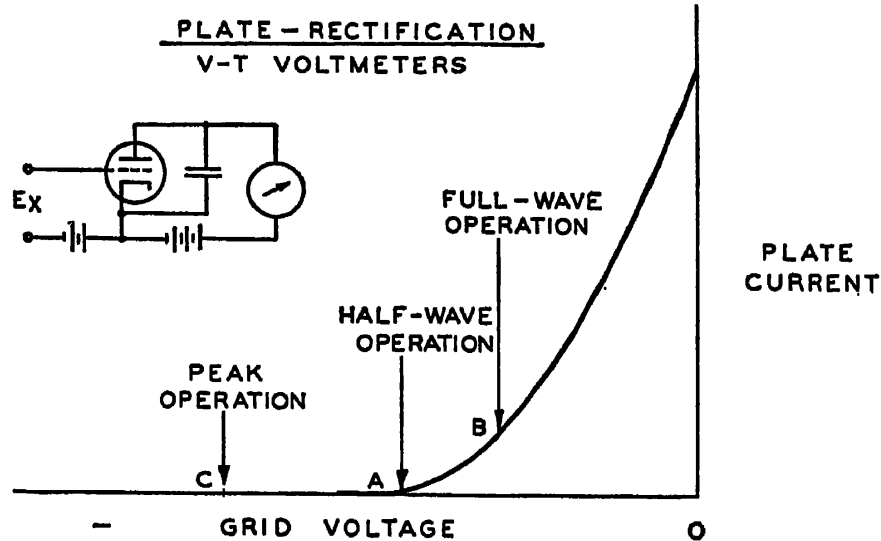

Fig. 3-1. Plate rectification v-t voltmeters are classified as *peak*, *half-wave* or *full-wave*,—depending upon the position of the operating point on the plate current—grid voltage characteristic.

Half-Wave Square-Law V-T Voltmeter

The basic circuit and operation of the half-wave square-law v-t voltmeter are shown in Fig. 3-2. As the designation *half-wave* implies, the operating grid bias is chosen close to cut-off so that the plate current is essentially zero when no signal is applied to the grid. When a signal is applied, the plate current increases during the positive half of the cycle, as is shown at (b). On the negative half, however, no appreciable decrease in the plate current takes place because the plate current is practically zero to begin with. As a result of this rectification, the average value of the plate current increases when a signal is applied, and this increase can be taken as a measure of the voltage applied to the grid.

Square-Law Response—The outstanding characteristic of this type of v-t voltmeter is the fact that the plate current is approximately proportional to the *square* of the voltage applied to the grid. This makes the calibration independent of the waveform, although there may still be some waveform error which is dependent upon the phase of the harmonics present in the unknown voltage. The compensation for variations in waveform cannot be complete in the half-wave type of v-t voltmeter because no current flows in response to the negative half cycles of the input voltage; as a result the waveform of the negative half cycles cannot directly affect the reading of the voltmeter.

Weak-Signal Operation—The sensitivity of the half-wave v-t voltmeter for small voltages is poor because these voltages are applied near plate current cut-off and in this region the mutual conductance of the tube is very low. An additional factor making the weak-signal sensitivity poor is the inherent insensitivity of any square-law type of v-t voltmeter for small input voltages.

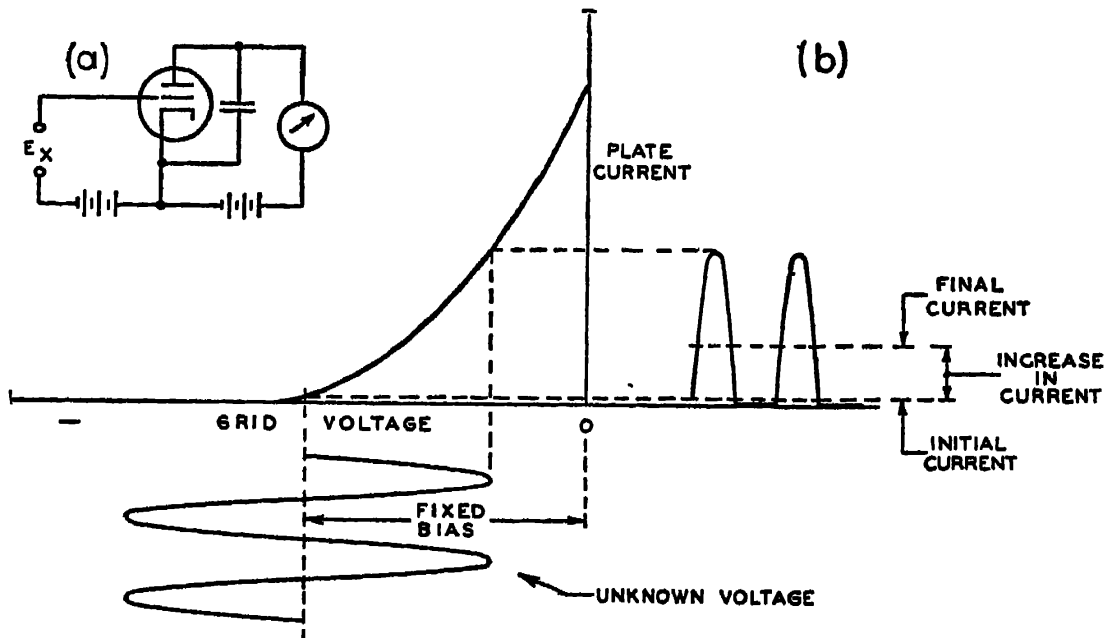

Fig. 3-2. The half-wave v-t voltmeter is operated just above plate current cutoff, so that only the positive half cycles of the applied voltage are effective in causing the plate current to increase. The meter indicates the increase in the average plate current.

In addition to having poor sensitivity for weak signals, the *accuracy* for weak signals depends to a very great extent upon the maintenance of the exact value of bias voltage. Even a slight shift in this voltage will throw off the calibration over the lower portion of the scale. By always using a fixed small value of operating plate current, as is illustrated in Fig. 3-3b, the stability of calibration can be improved considerably.

Strong-Signal Operation—For stronger input signals where operation is on the upper portion of the plate-current characteristic far removed from cut-off, the sensitivity is considerably better than for weak signals. Here the calibration is not so dependent upon the exact maintenance of the correct voltages. In practical v-t voltmeters, the triode plate-current characteristic is such that the square-law relation is maintained only over a limited portion of the range. For larger input signals, the response tends to become linear so that the increase in plate current is proportional to the signal rather than to the *square* of the signal. The reason for this condition can be seen from the manner in which the

plate current characteristic in Fig. 3-2b straightens out as the bias voltage is decreased. Since the response for large signals is no longer proportional to the square of the grid voltage, the voltmeter then tends to read the *average* rather than the *rms* value of the positive half cycles, and its reading is therefore dependent upon the waveform of the signal in the same way as any other average-reading voltmeter.

Input Resistance and Frequency Range—The input resistance of the half-wave v-t voltmeter is extremely high because the grid is at all times biased negatively. The exact input resistance depends upon the frequency and the tube type but is in general hundreds of megohms at low frequencies and correspondingly lower at higher frequencies. However, the input resistance remains high even at radio frequencies where it is limited by the losses in the input circuit of the tube. These losses can be minimized at the upper radio frequencies by using an acorn type tube such as is illustrated in Fig. 1-1.

The frequency range of the half-wave v-t voltmeter extends to approxi-

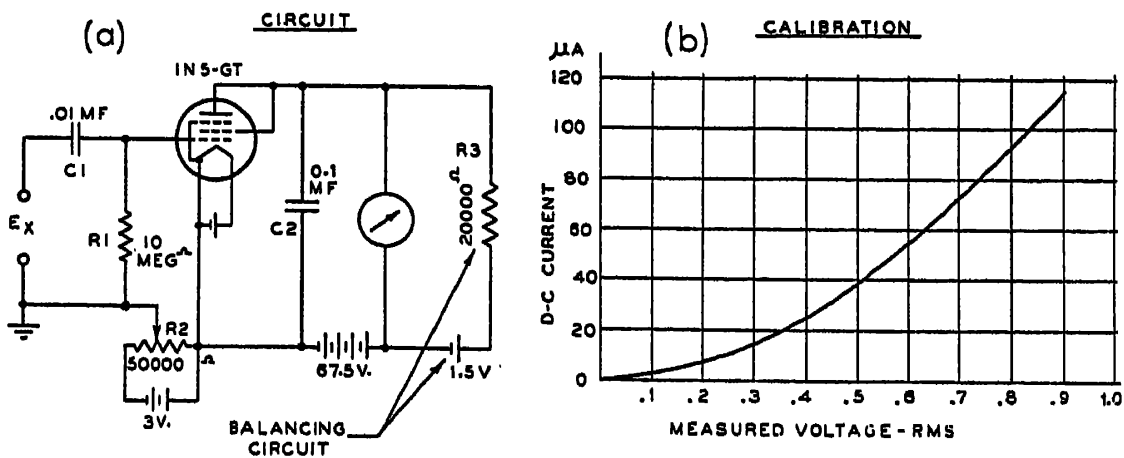

Fig. 3-3. A half-wave v-t voltmeter using a type 1N5-GT connected as a triode. A fixed balancing current is used, the zero adjustment being made by means of R2; a 500 ohm rheostat may be placed in series with R2 to obtain a fine adjustment control. A typical calibration curve is shown at (b).

mately 30 megacycles so that a calibration made at a low frequency (such as 60 cycles) can be used at radio frequencies. At about 30 megacycles, the transit time of the electrons in the space between the elements introduces an error which becomes progressively larger as the frequency is increased.

Half-Wave V-T Voltmeter Using 1N5-GT

The circuit shown in Fig. 3-3a illustrates a practical half-wave v-t voltmeter having an approximate square-law characteristic. A type 1N5-GT r-f pentode is used as a triode; this tube has a 1.5-volt, 50-

milliampere filament and is designed for direct operation from a 1.5-volt dry cell. It is particularly suitable for v-t voltmeter use because of its small size, low input capacitance, and because the grid cap is on top of the envelope so that the tube can readily be adapted for use at the end of a probe (see pages 53 and 78.)

Although the circuit and curves shown apply specifically to the 1N5-GT tube, similar curves apply to a-c operated v-t voltmeters using other tubes which have similar characteristics. The reason for the use of a pentode (as a triode) rather than a conventional triode is the fact that the triode types do not usually have the grid cap at the top of the envelope. When used as a triode, sharp cut-off pentodes of the 1N5-GT, 77, 6SJ7, and similar types have an amplification factor of the order of 25. Similar performance can be expected with any of these tubes used as triodes, or with a triode having an amplification factor of about 25.

Circuit Description—The circuit is similar to the basic circuit which has already been described with the exception that a balancing circuit has been added to balance out the initial value of plate current. This balancing circuit consists of the 1.5-volt flashlight cell and the resistor $R3$. A 50,000-ohm potentiometer $R2$ across a 3-volt battery is used to provide the grid bias, while a 67.5-volt battery is used for the plate voltage. A 100- or 200-microampere meter is used as the indicator.

The r-f currents which are caused to flow in the plate circuit are returned to the cathode by means of the 0.1-mf bypass condenser $C2$. This prevents signal currents from flowing through the meter and plate-supply circuits where they would encounter a variable impedance which would introduce a frequency error.

The unknown voltage may be connected directly to the grid or through the blocking condenser $C1$ as shown in Fig. 3-3a. If the blocking condenser is used, the calibration will be unaffected provided that the reactance of $C1$ at the lowest frequency of operation is small in comparison with the resistance of $R1$.

Operating Point—An examination of the plate current-grid voltage characteristic of the 1N5-GT (see Fig. 3-4) when operated at a plate voltage of 67.5 volts shows that the plate current is quite small for a grid bias of about 2 volts. At this grid bias, the operation would be essentially half-wave. Larger values of grid bias could be used; as will be shown later this has the disadvantage of reducing the sensitivity for weak signals. A good compromise value of grid bias is therefore about 2 volts and the plate current corresponding to this value is about 75 microamperes.

To insure that the operating point will always be returned to this initial value of current a fixed balancing resistor is used. This resistance is set at 20,000 ohms so that the balancing current is 75 microamperes. To set the zero when the voltmeter is first turned on, the potentiometer

should be adjusted until the meter reads zero. Since the balancing current is 75 microamperes, the plate current will also be 75 microamperes when the meter reads zero.

Calibration and Range—A typical calibration is shown in Fig. 3-3b. The square-law character of this curve for voltages less than 1 volt is apparent. Note, for example, that an input signal of 0.4 volt produces a deflection of about 25 microamperes. Doubling the input signal to 0.8 volt raises the plate current to 94 microamperes or approximately *four* times the deflection for the 0.4-volt signal which was *half* as strong. For larger values of input signal the deflection tends to become linear as the curve shows. Larger input signals than about 1.4 volts rms (or 2 volts peak) should not be applied since the grid will be driven positive and the input resistance lowered.

It is clear from the preceding description that the range of this v-t voltmeter is limited because an input greater than 2 volts peak will cause grid current to flow. When it is necessary to measure larger

Fig. 3-4. The plate current-grid voltage characteristic of the type 1N5-GT connected as a triode. This tube is used in the half-wave and full-wave v-t voltmeter circuits shown in Figs. 3-3 and 3-6.

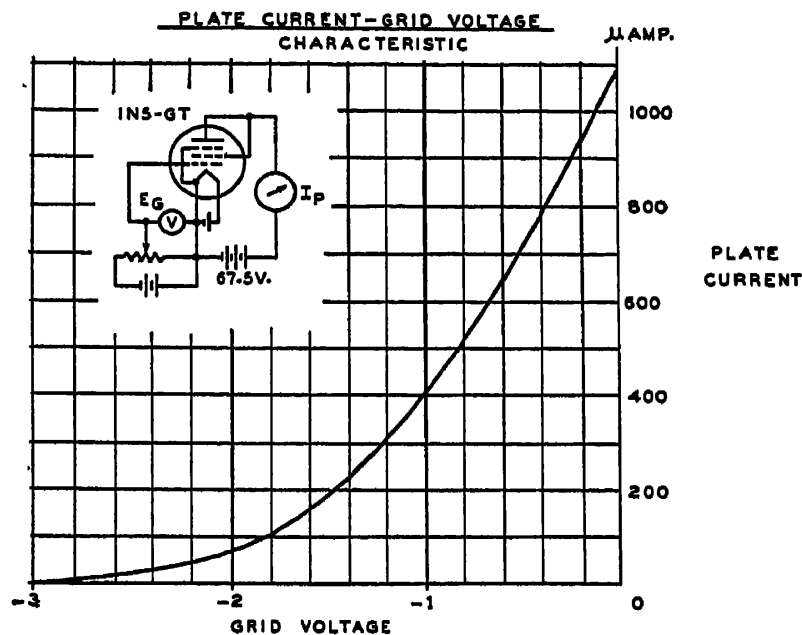

voltages than this, some modification must be made in the design. One way of obtaining an extension of the range is to use a tube with a lower amplification factor. This will increase the cut-off bias (the cut-off voltage is approximately equal to the plate voltage divided by the amplification factor) and so will increase the maximum signal which can be applied without drawing grid current. Increasing the plate voltage will also increase the range, but this is generally unsatisfactory because it reduces the sensitivity for small input voltages. The most satisfactory solution where higher voltages must be measured is to use one of the other types of v-t voltmeters, such as the rectifier-amplifier or slide-back type.

Numerous modifications can be made in this basic circuit. For example, other tubes such as the 6C5, 6J5, 6P5, 6J7 (as a triode) may be used; full a-c operation can be obtained by using a conventional power supply; etc. Although any of these changes will affect the calibration, they will not alter the general considerations which have been discussed.

Full-Wave Square-Law V-T Voltmeter

If the operating point of the half-wave type v-t voltmeter is moved above cut-off so that an appreciable value of plate current flows, then the operation changes from *half-wave* to *full-wave*. The designation *full wave* is appropriate, as Fig. 3-5 shows, because both halves of the

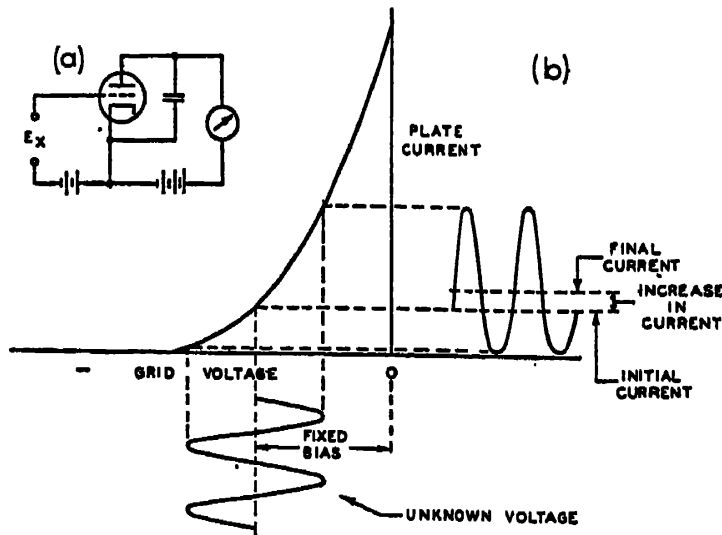

Fig. 3-5. For full-wave operation, the operating point is placed on the curved portion of the characteristic, so that the increase in plate current on the positive half cycle is greater than the decrease on the negative half cycle. The meter indicates the increase in the average plate current.

wave are effective in causing the plate current to change. Because the plate-current increase on the positive half cycle is greater than the decrease on the negative half cycle, there is a net increase in the plate current when a signal is applied. This increase in current may be taken as a measure of the signal applied to the input, and the voltmeter is calibrated accordingly.

Elimination of Waveform Error—Where the tube characteristic is such that the plate current is proportional to the *square* of the grid voltage, the full-wave v-t voltmeter has the very desirable property that waveform error is eliminated and the reading is proportional to the *rms* or *effective* value of the signal. In this respect the full-wave, square-law v-t voltmeter is superior to the half-wave type which does not take into account the negative half cycles of the input voltage. In the full-wave type both the negative and the positive half cycles contribute to the reading; because of the square-law response, the increase in plate current is proportional to the rms value of the input voltage and is independent of the waveform.

Sensitivity—At first consideration it might be thought that the full-wave voltmeter would be less sensitive than the half-wave type because of the decrease in plate current on the negative half cycles of the input voltage. This decrease does partially neutralize the increase on the positive half cycles and so tends to reduce the rectification efficiency. In the full-wave circuit, however, operation is on a portion of the plate characteristic where the mutual conductance is greater than for half-wave operation. This greater mutual conductance more than compensates for the decrease in plate current on the negative half cycles, so that the sensitivity of the full-wave v-t voltmeter is greater than the sensitivity of the half-wave type.

The statements made regarding input resistance and frequency range under the half-wave type of v-t voltmeter apply equally well to the full-wave type.

Full-Wave V-T Voltmeter Using 1N5-GT

A full-wave v-t voltmeter circuit having an approximate square-law response is shown in Fig. 3-6. The same tube and general circuit ar-

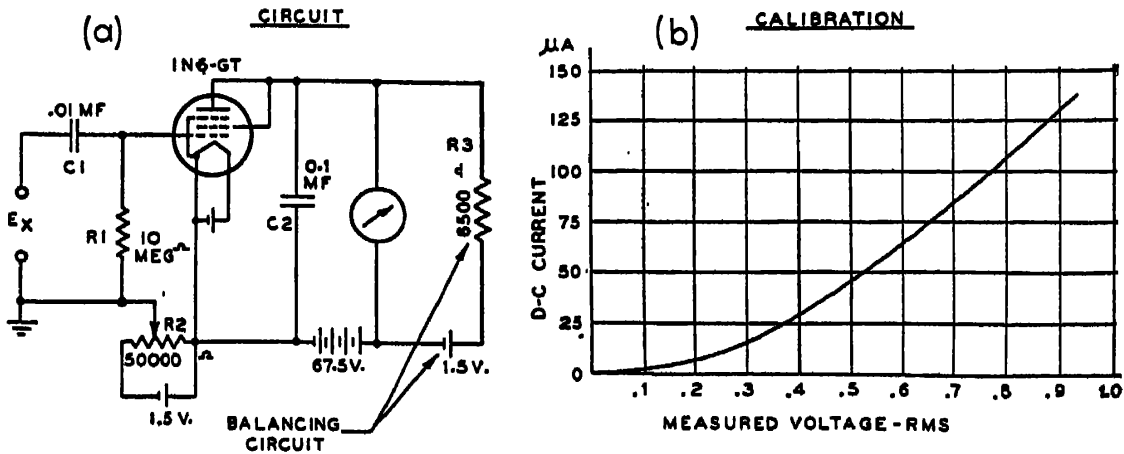

Fig. 3-6. A full-wave v-t voltmeter using the type 1N5-GT connected as a triode. A fixed balancing current is used, the zero adjustment being made by means of R2; a 500-ohm rheostat may be placed in series with R2 where a fine adjustment control is desired. A typical calibration curve is shown at (b).

rangement previously described in connection with the half-wave v-t voltmeter of Fig. 3-3 are used in this circuit. The only significant change is the decrease in the bias voltage so that plate current will flow for both the positive and negative parts of the input voltage.

Referring to the plate-current characteristic of the 1N5-GT shown in Fig. 3-4, the operating point is moved up to a bias of 1.4 volts and the corresponding plate current of about 230 microamperes. To obtain the required balancing current, the same 1.5-volt battery may be used.

However, the balancing resistor $R3$ should be decreased to about 6500 ohms so that a balancing current of approximately 230 microamperes will flow through the meter. When the grid-bias potentiometer $R2$ is adjusted so that the meter reads zero, the plate current will then be exactly equal to the balancing current and operation will be taking place about the correct point on the tube characteristic.

With the circuit constants shown, the range of the voltmeter is limited to about 1 volt rms since larger input voltages will cause grid current to flow. To measure voltages larger than 1 volt it is preferable to use a tube which has a lower amplification factor, if square-law operation is desired. The types 71-A and 6AE5-GT are especially suitable for this application.

Ideal Square-Law V-T Voltmeter

In a perfect square-law v-t voltmeter, the plate current is exactly proportional to the square of the grid voltage. An ideal characteristic of this type is shown in Fig. 3-7a. The square-law character of the plate current curve is readily apparent. To obtain plate-current cut-off, a

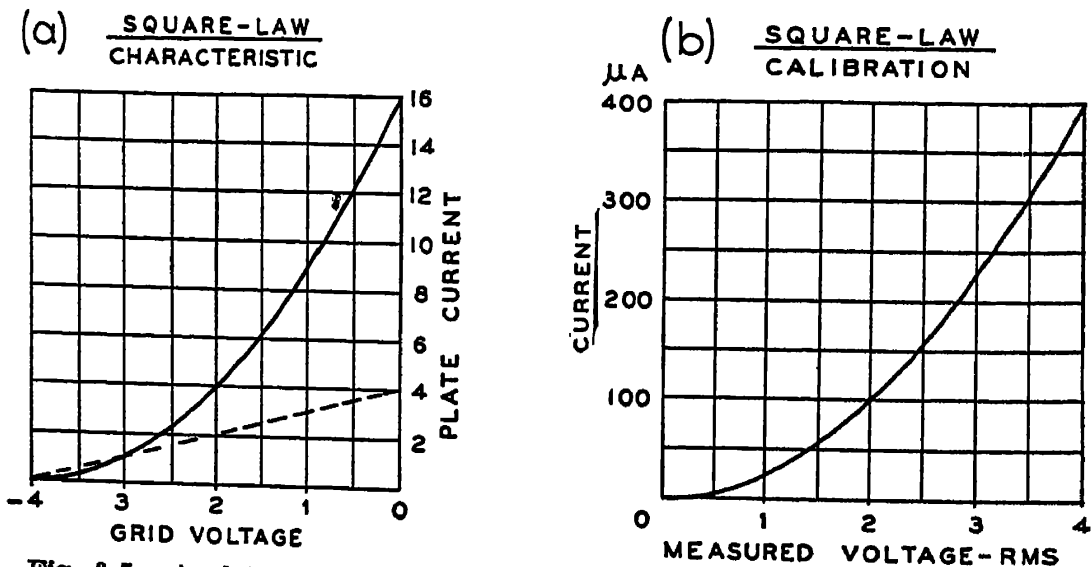

Fig. 3-7. A plate current-grid voltage characteristic can be checked for square-law response by plotting the square-root of the plate current, as shown by the dotted straight line at (a). A v-t voltmeter biased at cutoff, and using this characteristic, will give the calibration shown at (b). See also Fig. 3-8.

grid bias of 4 volts is required. If this bias is reduced by 1 volt, the plate current increases to 1 milliamperes. If bias is decreased by *twice* this amount (to 2 volts), the plate current is multiplied by *four* and is thus 4 milliamperes. If the grid bias is decreased by *three* times the original 1 volt decrease (to 1 volt), the plate current is multiplied *nine* times and thus becomes 9 milliamperes. Similarly for a *four* time de-

crease in grid voltage, the plate current increases *sixteen* fold, so that at zero bias the plate current is 16 milliamperes.

To check whether a given characteristic is square-law, the *square root* of the plate current readings are plotted against the grid voltage. If a straight line is obtained,—as the dotted line in Fig. 3-7a—this indicates that the square root of the plate current is proportional to the grid voltage; this is simply another way of stating that the plate current is proportional to the *square* of the grid voltage. In the case of the ideal square-law plate current curve just described, the square-root curve is a straight line, indicating that perfect square-law operation would be obtained if a tube having a characteristic shown in Fig. 3-7a were used as v-t voltmeter. Since the dotted curve is straight over its entire length, square-law operation would be obtained regardless of the position of the operating point. If the grid bias were at cut-off or -4 volts, then *half-wave* square-law operation would be obtained, whereas if the operating point were at -2 volts, then full-wave square-law operation would result.

Fig. 3-8. The scale of a perfect square-law v-t voltmeter is crowded over the lower portion so that it is difficult to take readings less than about $\frac{1}{4}$ of full scale. Note the much greater ease of reading on the linear scale which is shown below the square-law scale to enable a comparison.

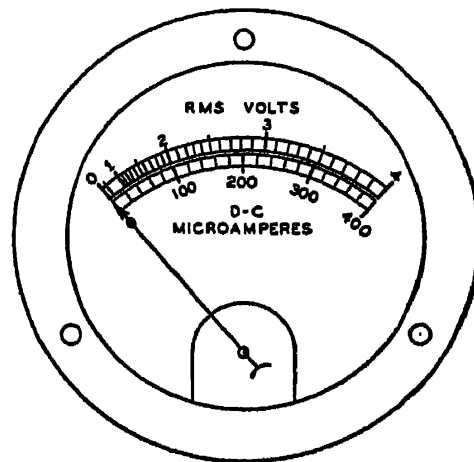

Square-Law Scale Distribution—The characteristics of a square-law scale are of interest. Fig. 3-8 shows the exact scale calibration for a half-wave v-t voltmeter having the plate current curve shown in Fig. 3-7a; however, the same type of scale calibration applies to all square-law v-t voltmeters regardless of type.

The essential characteristic of a square-law scale is the crowded appearance of the lower portion of the scale. Thus an input voltage equal to *one-half* the full-scale voltage gives a deflection of only *one-fourth* of full scale, while an input voltage of *one-tenth* of full scale gives a deflection equal to only *one-hundredth* of full scale. The practical effect of this square-law distribution is to limit the range of voltages which can be read on any one scale to a value much lower than for a linear scale. For example, a deflection of one division on a 100-division scale requires 1% of the full-scale voltage for a *linear* voltmeter, whereas it requires 10% of the full-scale voltage for a square-law v-t voltmeter.

Clearly, then, a square-law v-t voltmeter requires a great many more ranges to cover the same range of voltages than does a voltmeter having a linear scale. Despite this disadvantage of the square-law v-t voltmeter, there are some limited and specialized applications where it is used in preference to the *peak* or *average-reading* v-t voltmeter. These applications are limited to those special cases where measurements are made on complex waves and where the rms value must be determined. The measurement of noise voltages is a typical application where a true rms v-t voltmeter is required.

Determining the Bias for Square-Law Operation

To determine the operating bias for plate rectification v-t voltmeters, the plate current should be plotted against the grid bias, so as to obtain a plate current—grid voltage characteristic similar to Fig. 3-4. In addition to this characteristic, it is desirable to plot the square root of the plate current against the grid voltage in order to determine the region over which the response will be square law. The latter curve need be plotted only if square-law operation is required. In addition to these two curves, it is desirable to plot another curve showing the variation in sensitivity with the operating bias.

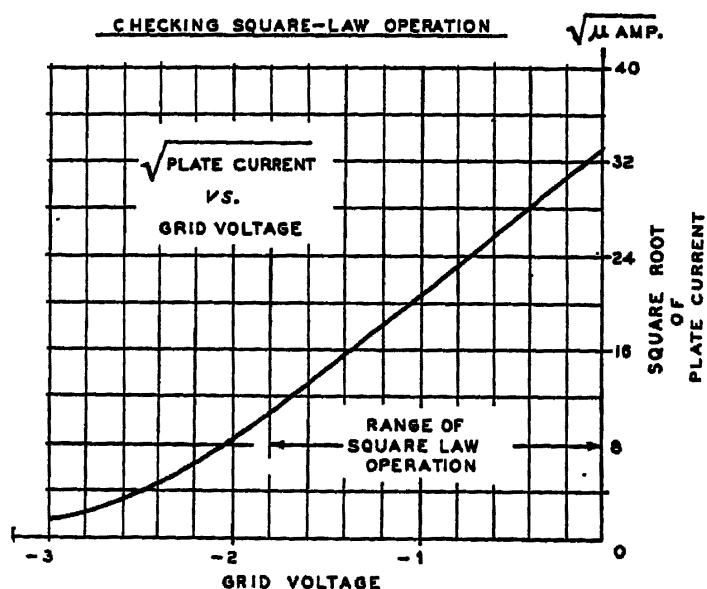

Fig. 3-9. To check for square-law operation, the square root of the plate current is plotted against the grid voltage (see Fig. 3-4). Square-law response will be obtained provided operation is restricted to the straight portion of the square-root curve.

The square root of the plate current plotted against the grid voltage for the 1N5-GT v-t voltmeters previously described is shown in Fig. 3-9. This curve is straight only over a portion of its length, indicating that perfect square-law operation can be obtained only by working over that particular section. This is in contrast to the ideal square-law characteristic which is straight over its complete range from cut-off to zero bias (see dotted curve of Fig. 3-7a).

Where square-law operation is of major importance, Fig. 3-9 shows that the range of operation should be restricted to the straight portion between 0 and 1.8 volts. The operating point should be in the middle of this range at about 1 volt.

Variation of Sensitivity with Operating Bias—Where square-law operation is not an essential, the operating point may be chosen without regard to whether it is in the middle of the square-law region. In any case, however, the efficiency of rectification, and hence the sensitivity, depend to a marked extent upon the proper location of the operating point. The manner in which the sensitivity is dependent upon the operating point is shown in Fig. 3-10. This curve was made by noting the

Fig. 3-10. The sensitivity of a plate rectification v-t voltmeter varies with the operating bias. The curve shows the increase in current for a 0.2 volt signal for various values of operating voltage, using the characteristic shown in Fig. 3-4.

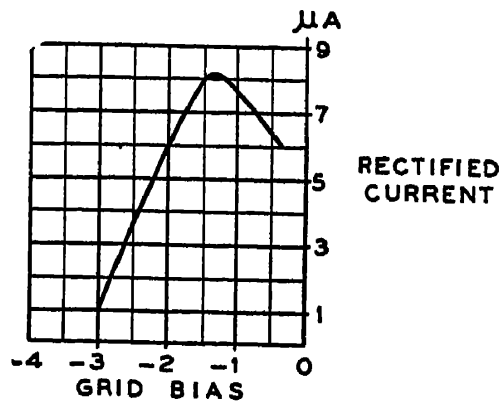

change in plate current which resulted when a 0.2-volt signal was applied with the operating point successively set at different values. The resulting curve shows that the greatest sensitivity is obtained when the operating point is in the neighborhood of 1.3 volts. At this point a 0.2-volt signal causes a change in plate current of about 8 microamperes. If the operating bias is increased, the sensitivity drops quite rapidly until at a bias of -3 volts (near plate-current cut-off) the sensitivity drops to about one-eighth of the maximum sensitivity. If the bias is made very small the sensitivity also decreases, but not so much as for values of grid bias larger than the optimum value. The decrease in efficiency for small values of bias is the result of the more linear plate current variation in this region. This makes the increase in current on the positive half of the cycle only slightly greater than the decrease on the negative half cycle so that the net increase is very small.

In choosing the operating point for full-wave square-law v-t voltmeters it is preferable to use a somewhat higher value of grid bias than would be called for by operation in the middle of the square-law region. This is desirable in order to reduce the operating current so that the current which has to be balanced out will not be too large in comparison with the rectified current. This helps to improve the stability of the zero reading and the permanence of the calibration, as well as to increase the input resistance.

Peak Plate-Rectification V-T Voltmeter

The half-wave and full-wave v-t voltmeters both use a value of operating bias which is less than cut-off, so that some plate current flows when no signal is applied. If the operating bias is increased beyond cut-off, however, a third type of v-t voltmeter operation is obtained. This type of operation is referred to as *peak* operation.

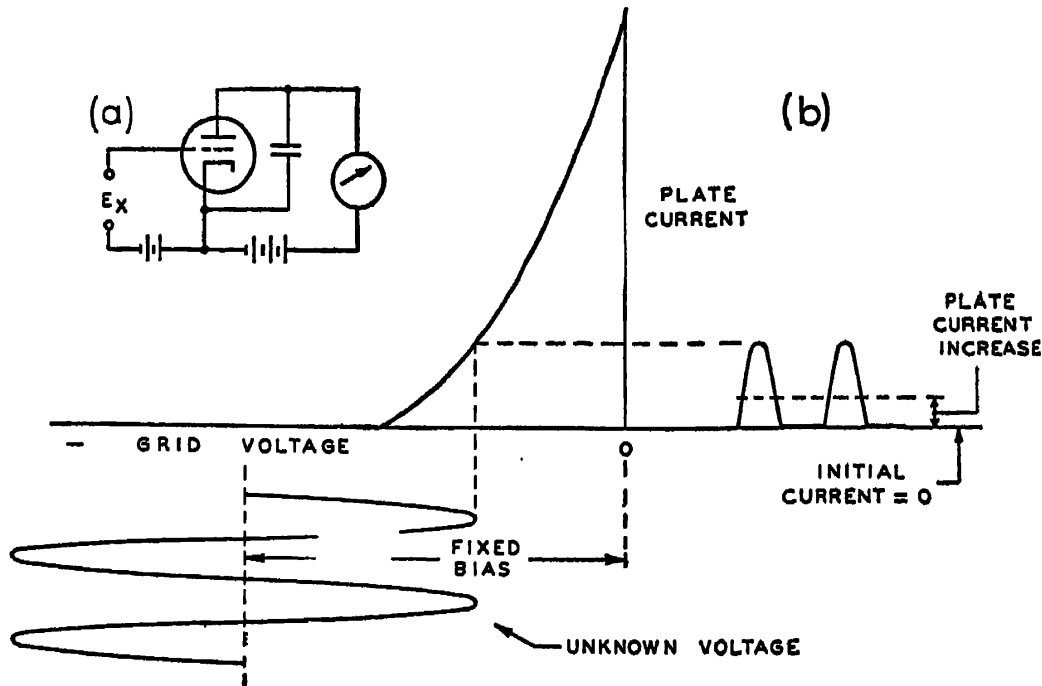

Fig. 3-11. In the peak plate-rectification v-t voltmeter, the operating bias is considerably beyond cutoff so that only the positive peak of the applied voltage is effective in causing the plate current to increase. Note that the range which can be covered on any one scale is less than the cutoff bias.

As Fig. 3-11 shows, peak operation corresponds to Class C amplifier operation in that plate current flows only during a part of the positive half cycle. The further beyond cut-off the tube is biased, the smaller is the interval during which current flows. Since no current flows when there is no applied signal, it is clear that a balancing circuit is not required.

The response of the peak type of plate-rectification v-t voltmeter is proportional to neither the peak, the average, nor the rms value of the plate current. However, as a closest approach, the reading is proportional to the peak value of the signal since only the peak part of the cycle is effective in causing an increase in current flow. More strictly, the response is proportional to the *average value of that part of the positive half cycle during which plate current flows*. Because considerably less than the full positive half cycle is effective in causing rectifica-

tion, the peak v-t voltmeter has a larger waveform error than any of the other types. In particular, its reading cannot even be called a *peak* reading, because the response depends to an appreciable extent upon the waveform of the voltage in the neighborhood of the positive peak.

A characteristic of the peak type of circuit is that the calibration does not begin with zero voltage at the left of the scale, but begins with a voltage considerably larger than zero. Thus a typical range for a peak plate rectification v-t voltmeter is from say 7 volts (at 0 on the scale) to 11 volts for full-scale reading. This type of calibration results because plate current does not flow until the applied peak signal voltage is sufficient to exceed the operating bias. At the point where current just begins to flow, the voltmeter is a true peak voltmeter, but as the signal voltage is increased beyond this value, the rectified current and hence the reading depends more and more upon the shape of the positive half cycle of the signal as well as upon its peak value.

Range—The range which can be covered on any one scale with a peak v-t voltmeter is limited to a value less than the cut-off voltage. As the operating bias is increased, the ratio between the highest and lowest voltages becomes very limited because the cut-off bias becomes small in comparison with the operating bias. For example, if the cut-off bias on a particular tube is 4 volts at the operating plate voltage, and the operating bias is 15 volts, then an 11-volt peak signal will just cause plate current to flow, so that zero current on the meter scale will correspond to 11 volts peak. The input voltage for this same range cannot exceed 15 volts peak or grid current will flow and loading take place. Thus the range covered on this peak v-t voltmeter would be limited to from 11 volts to 15 volts peak, a range of less than 1.5 to 1.

As would be expected, peak voltmeters of this type have an extremely limited application. For the most part their use is limited to multi-range v-t voltmeters where peak operation enables an extension of the range to about 15 volts full-scale. In voltmeters of this type, the successive ranges utilize *full-wave* operation, then *half-wave* operation, and finally *peak* operation on the higher ranges.

Grid-Rectification V-T Voltmeter

The triode v-t voltmeter shown in Fig. 3-12 is based on *grid rectification* rather than on plate rectification as are the half-wave, full-wave, and peak v-t voltmeters described in the preceding sections. The *grid-rectification* or *grid-detection* v-t voltmeter is similar to the now obsolete grid detector. Its distinguishing features are high sensitivity for weak signals of the order of 0.1 to 1 volt, and a comparatively low input impedance which results because its operation depends upon the flow of grid current.

The grid-rectification circuit is often convenient where the use of a

sensitive meter is undesirable and where a high input resistance is not required. It is not recommended, however, that elaborate circuits, including meter shunts and other refinements, be built up around the grid-rectification circuit. Other types of v-t voltmeters, in particular the rectifier-amplifier type described in Chapter V, are more suitable for use in multi-range v-t voltmeters.

Operation—The operation of the grid-rectification v-t voltmeter can be most easily understood by considering that it functions in much the same way as a diode rectifier followed by a triode amplifier. This equivalence is indicated in Fig. 3-12b which shows that the grid-cathode sections of the triode operate in exactly the same manner as a diode rectifier. Thus when a signal is applied to the grid, the grid draws current on the positive peaks with the result that the input condenser C becomes charged negatively. The way in which the potential at the grid varies with the applied signal voltage is shown in Fig. 3-12c. This curve shows that a small negative voltage is present at the grid even when no signal is applied. This negative voltage is due to the initial speed of the electrons leaving the cathode and is similar to the "contact potential" effect explained on page 25. As the input signal is increased, the control grid (which corresponds to the diode plate) becomes more and more negative. As a rough approximation, the negative voltage developed at the grid is somewhat less than the peak value of the applied signal.

The negative voltage developed at the grid by means of rectification in the grid-cathode circuit is effective in controlling the plate current, since the grid is not only the "diode plate" but it is also the triode control grid. Because of the controlling action of the grid on the plate current, the plate current *decreases* progressively as the input voltage is increased. This variation in plate current, shown in Fig. 3-12d, is to be expected since the grid becomes more negative for increasing input voltages and hence the plate current is correspondingly reduced.

Sensitivity—The grid-rectification v-t voltmeter is primarily suitable for the measurement of small voltages ranging from about 0.1 volt to several volts. Over this range, and especially for voltages of the order of a few tenths of a volt, the grid rectification v-t voltmeter is quite sensitive. For example, a plate-current decrease of about 300 microamperes for a 0.5-volt signal can readily be obtained; under the same conditions a plate-current decrease of about 1000 microamperes can be obtained for an input signal of 1 volt. Because of this comparatively large plate-current change, a relatively insensitive meter can be used in grid-rectification v-t voltmeters.

High Initial Current—A disadvantage of the grid-rectification v-t voltmeter is the comparatively high value of plate current which flows when no signal is applied. This high plate current is a result of operation at zero bias. Because of this high *zero-signal* plate current,

even a very small variation in the filament or plate voltage will cause an appreciable shift in the zero reading. Usually the plate current is of the order of several milliamperes depending upon the amplification factor of the tube and the plate voltage. To reduce erratic changes and wandering of the zero reading, it is desirable to use either battery operation or a regulated a-c power supply. The initial current can be kept to a minimum by using high- μ triodes, such as the 6Q7, 6K5G and 6SC7.

An effective means for minimizing zero drift is to use a two-tube balanced circuit such as is shown in Fig. 3-22. This latter circuit also has the advantage that the comparatively large balancing current required does not throw the meter off scale during the warm-up period.

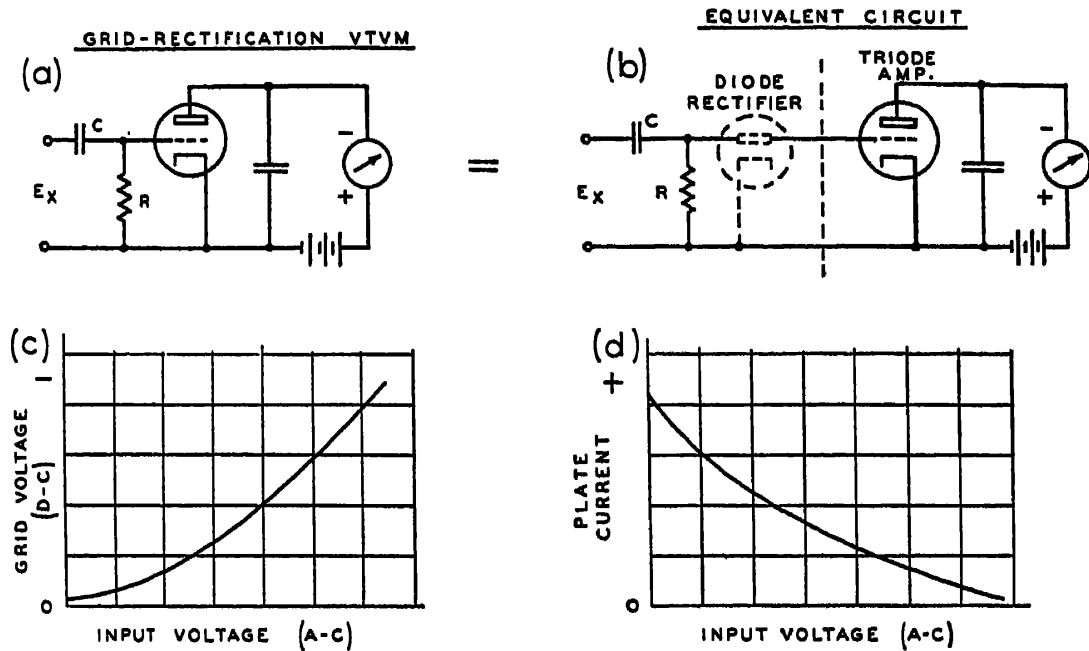

Fig. 3-12. The grid-rectification v-t voltmeter can be considered roughly equivalent to a diode rectifier followed by a triode amplifier. When a signal is applied, the grid is driven negative and the resulting decrease in plate current can be taken as a measure of the unknown a-c voltage.

Low Input Impedance—Although the grid-rectification v-t voltmeter is of the triode type, it has an unusually low input resistance because of the operation at zero bias. Unlike the biased type of triode v-t voltmeter where no grid current is drawn, the grid-rectification type depends upon the flow of grid current and it is this grid current which results in loading of the circuit under test.

The loading of the grid-rectification v-t voltmeter is approximately the same as that of a diode rectifier having a load resistor equal to the grid resistor. For small values of input signal, however, the input resistance of the grid-rectification type is even lower than for the

comparable diode v-t voltmeter. As the input signal is increased, the input resistance becomes progressively larger because the grid is biased more negatively.

It might seem that the input resistance could be increased by using a large grid resistor. This, however, is not effective for weak signals since the losses are in the tube itself and not in the grid resistor. For example, a typical grid-rectification v-t voltmeter using a 2-megohm grid resistor may show an input resistance as low as 100,000 ohms (at 60 cycles) even though the grid resistor is much larger than this.

It is undesirable to use excessively high values of grid resistance in an attempt to increase the input resistance of the grid-rectification v-t voltmeter. Not only is this ineffective, but the use of a large grid resistor will cause instability, erratic variations in the plate current, and consequent wandering of the zero. Usually there is no advantage in using a grid resistor higher than several megohms.

Grid Resistor and Condenser—The shunt type of input circuit shown in Fig. 3-12a is preferable to the type of circuit in which the grid resistor is connected in parallel with the grid condenser. The latter circuit (corresponding to Fig. 2-6) has the disadvantage that the grid condenser does not function as a d-c blocking condenser and that the zero adjustment depends upon the resistance of the circuit in which the measurement is made. The value of C should be such that its reactance at the lowest operating frequency is small in comparison with the resistance of R . A condenser having a capacity of about 0.01 mf is satisfactory for all frequencies down to a few hundred cycles. A 0.25-mf condenser will permit operation down to 60 cycles with negligible error, provided the grid resistor is at least 1 megohm.

Comparison with Separate Diode and Triode—The grid-rectification v-t voltmeter is not as flexible as the *rectifier-amplifier* type described in Chapter V. In the latter circuit the diode rectifier is completely separate from the triode amplifier. This separation has the desirable advantage of making it possible to use self bias in the triode amplifier and to operate the triode under the best conditions without affecting the performance of the diode. On the other hand in the grid-rectification v-t voltmeter, the triode cannot be biased separately as an amplifier since the bias would affect the operation of the grid-cathode section as a rectifier.

Response—For weak signals the response of the grid-rectification v-t voltmeter is approximately square law. This square-law response for weak signals is due to the curvature of the grid current-grid voltage characteristic in the neighborhood of zero bias. For larger values of input signal, however, the response becomes linear and is roughly proportional to the positive peak of the signal. The maximum change in plate current is always limited to a value somewhat less than the initial value of current with no signal. Actually the change in plate current

never quite equals the full value of the initial plate current because—no matter how strong a signal is applied—the grid will still be driven slightly positive on the very positive peak of the signal. As a result the plate current can never be driven to cut-off, although it can be made to approach cut-off within about 25% of the zero-signal current. From the viewpoint of accidental overload, it follows that the maximum current through the meter is limited to a value less than the zero-signal plate current.

Grid-Rectification V-T Voltmeter Using a 1G4-G Triode

The circuit of a practical grid-rectification v-t voltmeter is shown in Fig. 3-13. This circuit uses a type 1G4-G triode which is somewhat similar to the type 30 tube, but has a 1.5-volt filament so that it is

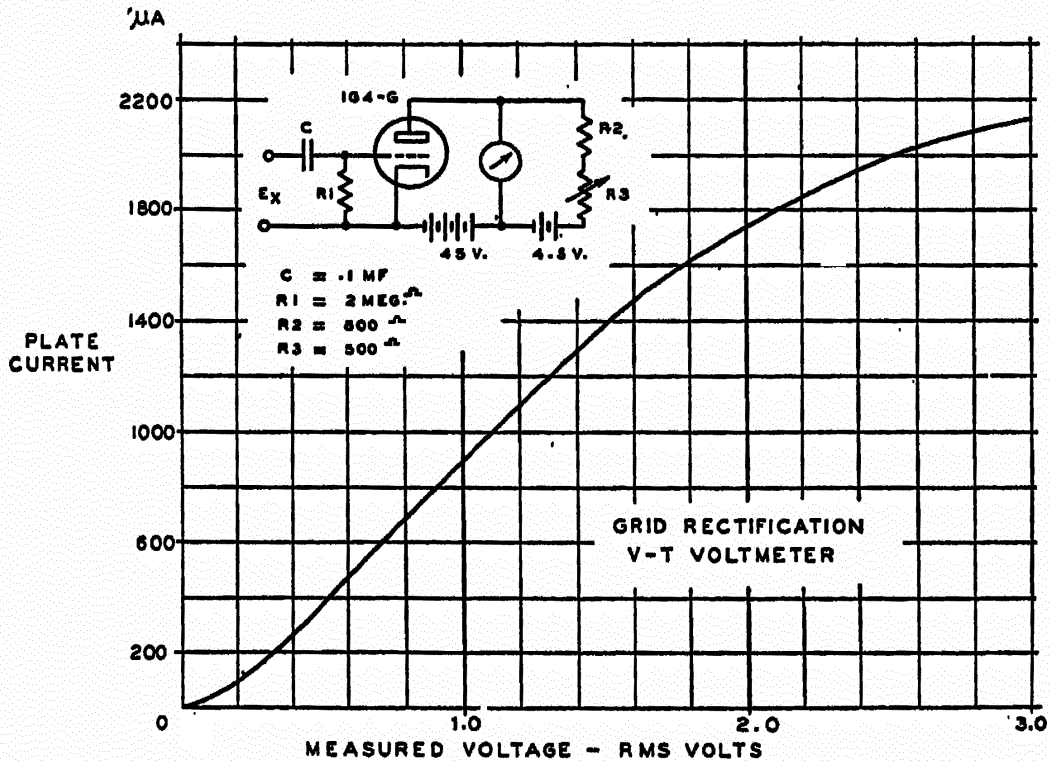

Fig. 3-13. The circuit and calibration of a typical grid-rectification v-t voltmeter. The positive terminal of the meter is connected to the plate so that the meter will swing up scale as the input voltage is increased.

more convenient to use than the type 30. The circuit is quite similar to the plate-rectification circuits previously shown with the important exception that operation is at zero bias so that no bias battery is required. The polarity of the meter connection is reversed in order that the decreasing plate current will cause the meter to read up scale.

The comparatively low plate voltage of 45 volts is used for two

reasons: (1) in order to keep the no-signal plate current as low as possible so as to obtain stable operation and (2) to improve the sensitivity for weak signals. The no-signal plate current for the circuit shown in Fig. 3-13 is 3.9 milliamperes. Since a 4.5-volt balancing battery is used, the balancing resistance should be approximately 1100 ohms.

Calibration—The calibration is shown in Fig. 3-13. Over the first part of the curve up to about 0.3 volt the response is approximately square law as is indicated by the curved characteristic. For input voltages greater than about 0.3 volt the response is essentially linear and continues to be linear for voltages up to about 1.5 volts. For voltages greater than about 1.5 volts the response gradually falls off and approaches a maximum value at about 3 volts. For example, for an input signal of 10 volts, the reading is 2.7 milliamperes, which is only slightly larger than the reading for 3 volts.

The input resistance of the grid-rectification v-t voltmeter varies with the input signal as has been previously mentioned. For this particular v-t voltmeter, the input resistance varies as shown in Fig. 3-14;

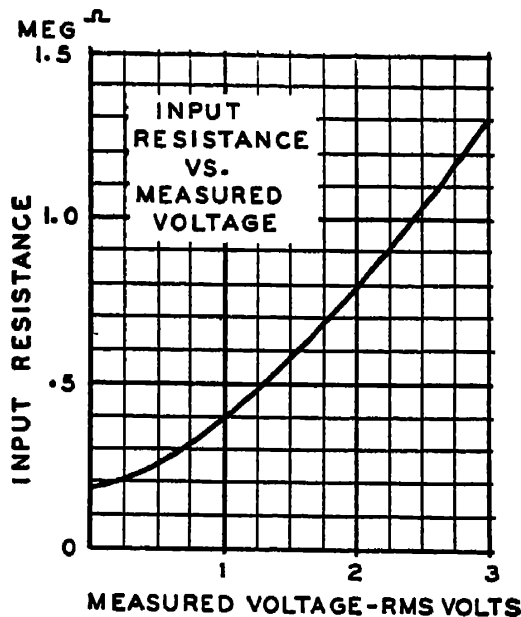

Fig. 3-14. The input resistance of the grid-rectification v-t voltmeter increases as the input voltage is increased. This higher input resistance is a result of the negative bias applied to the grid as a result of rectification of the applied voltage (see Fig. 3-12c).

there measurements were made at 60 cycles. Note that the input resistance increases from a low value of about 200,000 ohms at a signal input of 0.1 volt to about 1.3 megohms at a signal level of 3 volts. This compares unfavorably with the plate-rectification type of v-t voltmeter where the input resistance is ordinarily of the order of hundreds of megohms for both weak and strong signals.

If an 0-1 milliamperemeter is used in this circuit, the calibration curve shows that full-scale deflection will be obtained for approximately 1.1 volts rms. The use of a meter more sensitive than 300 micro-

amperes full scale is not recommended because of zero drift and the possibility of accidental overload. A 300-microampere meter would permit full-scale deflection to be obtained for an input signal slightly less than 0.5 volt.

Self-Bias or Reflex V-T Voltmeter

The v-t voltmeter circuit shown in Fig. 3-15 is commonly designated as the *self-bias* or *reflex* type. It is generally similar in operation to the plate-rectification circuits previously described with the important

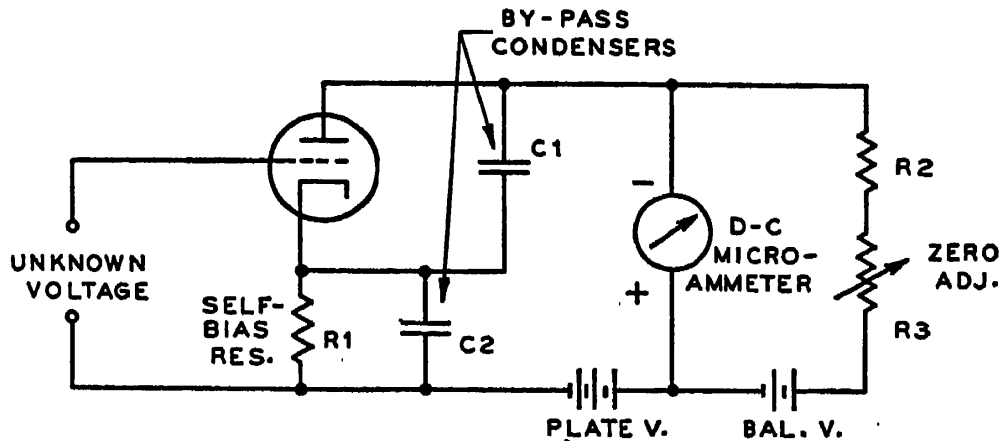

Fig. 3-15. A self-bias or reflex v-t voltmeter in which the bias voltage is supplied by the voltage drop across the cathode resistor R_1 . Although the self-bias circuit results in improved stability, the sensitivity is reduced because of the resulting degeneration.

exception that the bias voltage is obtained from the voltage drop resulting from the flow of plate current through the cathode resistor R_1 . Because of this self-biasing action the sensitivity is reduced by an amount depending upon the value of the cathode resistor. To compensate for this reduced sensitivity, however, the self-bias v-t voltmeter has the advantage of an approximately linear calibration (except on the low ranges) and greater stability than the fixed-bias type. This increase in stability results because the operating bias automatically tends to compensate for changes in the operating voltages and tube characteristics.

Because of the reduction in sensitivity accompanying the use of self bias, the principal application of the self-bias circuit is in v-t voltmeters which have full-scale ranges above about 2 volts. To obtain full-scale deflection for signals smaller than about 1 volt requires the use of a microammeter having a sensitivity better than 100 microamperes. In view of the comparatively high value of no-signal plate current, the use of meters more sensitive than 100 microamperes is not recommended.

The self-bias rectifier circuit can also be used in conjunction with a d-c amplifier to provide a sensitive v-t voltmeter covering a wide range of voltages. This type of circuit is described in Chapter V.

Operation—The plate current of the self-bias v-t voltmeter depends upon the value of the cathode resistor $R1$. The greater the resistance of $R1$, the greater is the bias produced and hence the smaller is the initial or no-signal plate current. When a signal is applied, the increase in plate current on the positive half of the input cycle is greater than the decrease on the negative half of the cycle. As a result plate rectification takes place, and there is a net increase in the plate current; this increase can be taken as a measure of the signal applied to the input. This operation is similar to the operation of the plate-rectification circuits previously described.

The alternating or high-frequency component of the plate current is returned directly to the cathode by means of the two bypass condensers $C1$ and $C2$ in Fig. 3-15. These condensers prevent an alternating voltage from being built up at either the cathode or the plate. To permit calibration at 60 cycles and the measurement of low-frequency voltages, $C2$ should be large enough so that its reactance at 60 cycles is small in comparison with the cathode resistance.

Although the cathode is bypassed, degeneration is introduced by the use of self bias rather than fixed bias. The manner in which the sensitivity is reduced may be seen from the following considerations. When a signal is applied, rectification takes place so that the average or d-c value of the plate current increases. This increase in plate current flows through the bias resistor, and therefore *increases* the bias voltage. Since an increase in bias voltage lowers the plate current, the overall effect of this action is a *smaller increase* in current than would have taken place if a bias battery or bleeder had been used to supply a *fixed* bias voltage.

As a result of the degenerative action just described, the self-bias type of v-t voltmeter tends to have a linear calibration on the higher voltage ranges. Another result of this action is that a higher range of signal voltages can be handled without overload taking place. This ability to handle larger voltages is due to the automatic increase in bias voltage which takes place as the input voltage is increased.

Input Circuit—The self-bias v-t voltmeter, like other plate-rectification v-t voltmeters, has a very high input resistance. Ordinarily the grid current is sufficiently small so that a blocking condenser and grid resistor are not required unless a d-c voltage is present along with the a-c voltage to be measured. Where tubes having a high amplification factor are used, however, it is desirable that a blocking condenser and grid leak be made a permanent part of the v-t voltmeter.

Self-Bias V-T Voltmeter Using a 954 Acorn Tube

The circuit and constants of a self-bias type of v-t voltmeter suitable for measurements extending up to about 50 megacycles is shown in Fig. 3-16.¹ This wide frequency range is secured by using an acorn type tube (see Fig. 1-1) which has exceptionally low losses at high frequencies, and by using the probe type of construction so as to permit a direct connection between the control grid and the point at which

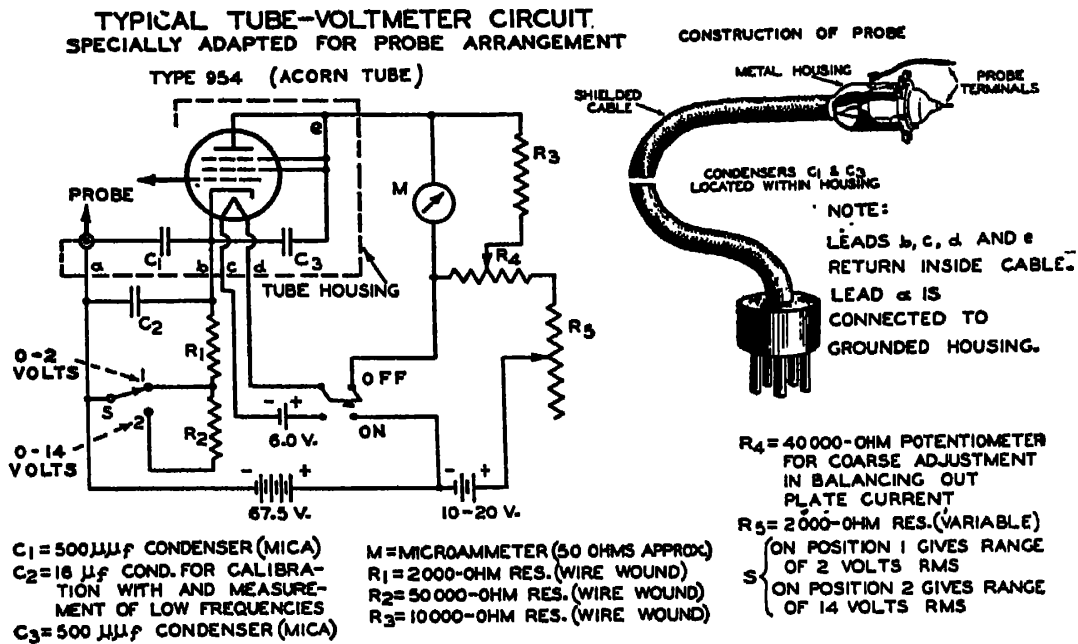

Courtesy RCA Manufacturing Co., Inc.

Fig. 3-16. A reflex v-t voltmeter which is especially designed for use at frequencies up to about 50 megacycles. The instrument may be constructed in three sections: the probe unit containing the 954 acorn tube, the control unit, and the power unit.

the voltage measurement is made. Two ranges are provided by using two different values of self-bias resistance. On the low range up to 2 volts rms can be applied before grid current flows, while on the high range the maximum voltage is about 14 volts rms.

The current arrangement is generally similar to the basic circuit previously discussed in connection with Fig. 3-15. The type 954 r-f pentode is used as a triode with the screen, suppressor, and plate connected together so as to form the triode plate. The input capacitance for this type of connection is approximately 1.4 mmf; this does not include any terminal connected to the grid which would of course increase the input capacitance.

¹This voltmeter is described in detail in Application Note No. 47, RCA Manufacturing Company, Inc.

A double-pole double-throw switch controls the filament, plate, and balancing voltages. The filament voltage may be supplied by four dry cells or by a 6-volt filament transformer. If the latter is used, the line voltage must be steady or there will be a shift in the zero with changes in line voltage. It is not recommended that plate and balancing voltages be obtained from a line-operated power supply unless a regulated supply is used.

To enable the measurement of low-frequency voltages and calibration at 60 cycles, it is necessary to use a large cathode bypass condenser. When this condenser is used (C_2 in Fig. 3-16) the 60-cycle calibration will hold at low audio frequencies and at all frequencies extending up to at least 25 megacycles. A 16-mf electrolytic condenser is satisfactory, since the capacity value is not critical. A high-voltage electrolytic should be used since its leakage resistance must be high in comparison with the cathode resistance. A small 500-mmf mica condenser provides adequate bypassing at the higher frequencies where the electrolytic condenser is not effective.

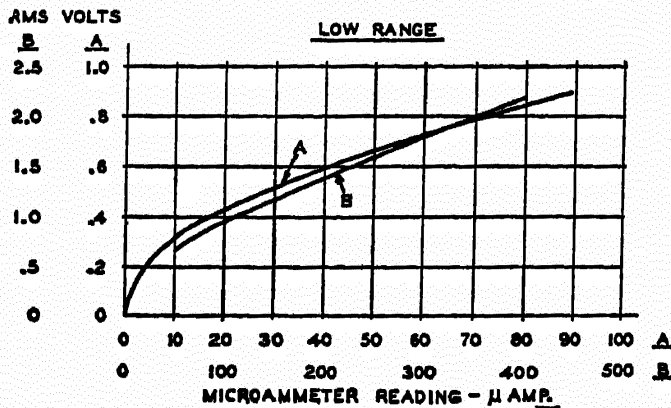

Typical calibration curves for the v-t voltmeter shown in Fig. 3-16.

Fig. 3-17.

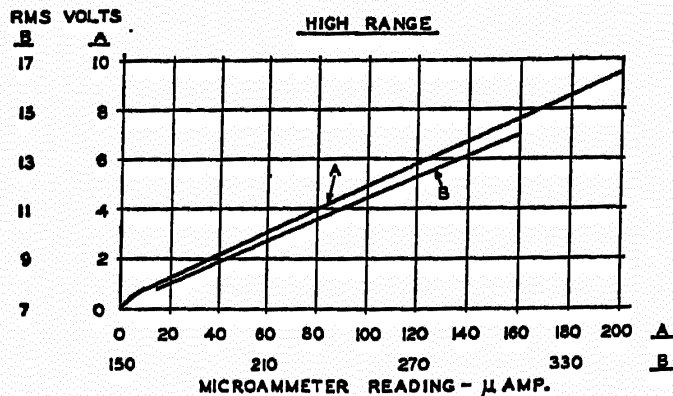

From a constructional standpoint the v-t voltmeter is divided into three units. The *probe unit* is indicated schematically in Fig. 3-16 by the dotted rectangle containing the tube and the r-f bypass condensers. The physical appearance of this unit is also shown in the

same figure. The *control unit* contains the various resistors, controls, range switch, and the electrolytic condenser. A *power unit* which is connected to the control unit supplies the heater, plate and balancing voltages. A multi-range microammeter providing full-scale ranges from 100 microamperes full scale to 500 microamperes full scale will permit accurate readings to be made, although a less sensitive meter can be used.

Variations in tube characteristics will cause the calibration to vary somewhat. However, the calibration curves in Fig. 3-17 hold approximately for any voltmeter which uses the circuit constants shown in the figure. The same performance can also be expected for v-t voltmeters using the same design but employing a conventional receiving tube such as the 1N5-GT or the 6J7 (as a triode). With either of the latter tubes the input capacitance will be larger as will also be the loading effect at high radio frequencies.

When a blocking condenser is used with this voltmeter, it is necessary to use a grid resistor to complete the grid circuit. A value of several megohms is satisfactory for general use, although higher values are preferable where the circuit impedance is high.

Balancing or Bucking Circuits

A number of different circuits are used to balance out the comparatively large value of initial plate current present in practically all types of v-t voltmeters. In some of these circuits the meter is located in the plate circuit while in others the meter is in the cathode circuit. All of these balancing arrangements, however, resemble each other a great deal. In all of them it is important to have the proper relation between the various components so that the balancing circuit will neither lower the sensitivity nor impair the stability.

A very common balancing circuit, which has already been used in connection with several of the preceding v-t voltmeters, is shown in Fig. 3-18a. The equivalent circuit shown at (b) in this figure makes it clear that the balancing circuit is essentially a bridge circuit. Two of the bridge arms are formed by the tube resistance and R_1 , while the other two arms are formed by the plate battery and the balancing battery. When no signal is applied, zero current will flow through the meter provided the usual bridge balance condition is satisfied:

$$\frac{R_1}{\text{Plate Resistance}} = \frac{E_1}{E_2}$$

When a signal is applied, the plate resistance of the tube is changed and the bridge balance is upset so that the unbalance current flows through the meter. In plate-rectification v-t voltmeters, the tube resistance *decreases* with the application of a signal so that the negative

terminal of the meter should be connected to the plate. In the grid-rectification circuit and in certain d-c amplifiers (see page 76) the plate resistance *increases* so that the positive terminal of the meter should be connected to the plate.

As the relation for the balance condition shows, a considerable latitude is possible in choosing the values of the balancing voltage $E1$ and the balancing resistor $R1$. Thus suppose that a balance is obtained when the balancing voltage $E1$ is 10 volts and the balancing resistor $R1$ is 10,000 ohms. A balance would also be obtained if $E1$ were 1 volt and $R1$ were 1000 ohms. Similarly a balance would be obtained if $E1$ were 50 volts and $R1$ were 50,000 ohms. It is worth noting that the balance condition does not depend upon the resistance of the meter, although the most desirable value of $R1$ and $E1$ is related to the meter resistance, as indicated in the following paragraph.

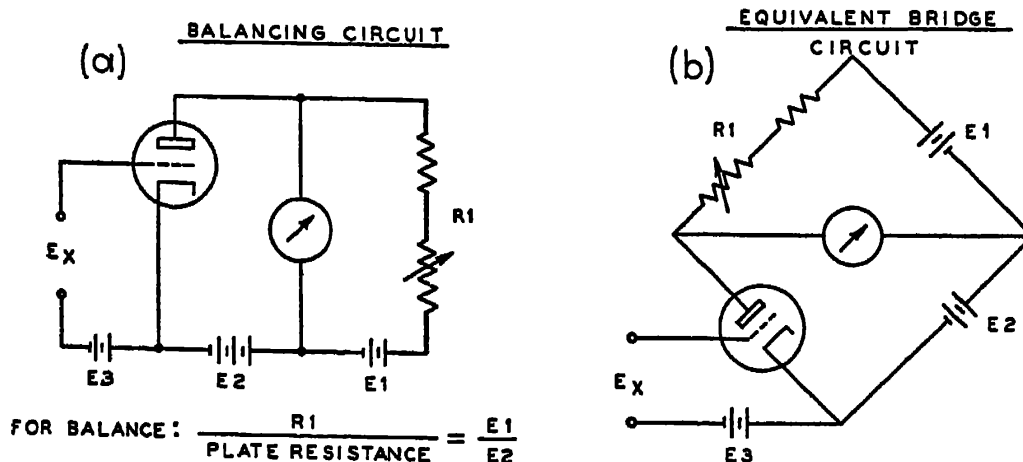

Fig. 3-18. A widely used circuit for balancing out the steady plate current. This circuit is equivalent to the bridge circuit shown at (b).

A convenient rule to follow in designing balancing circuits is to select first the balancing resistor $R1$ so that it has at least ten times the meter resistance. Thus if the meter resistance is 100 ohms, the balancing resistor should be at least 1000 ohms and preferably greater. The value of the balancing voltage can then be determined from the relation:

$$E1 = (\text{Plate Current}) \times R1$$

That is, the balancing voltage should be equal to the voltage drop of the zero-signal plate current across the balancing resistor.

The balancing resistance is made large in comparison with the meter resistance in order to prevent the change in the plate current (when a signal is applied) from going through the balancing resistor instead of through the meter. On the other hand, if the balancing resistance

is about the same as the meter resistance, then only a fraction of the change in the plate current will flow through the meter and thus the sensitivity will be reduced. In practice the resistance of the meters used in v-t voltmeters is of the order of several hundred ohms, so that it is usually possible to make $R1$ at least ten times the meter resistance without using excessively high values of balancing voltage. Where sensitive meters which have several thousand ohms resistance are used, the balancing voltage may have to be made as high as 50 volts in order to prevent a reduction in the sensitivity.

Balancing Circuit Using Voltage Divider

The balancing circuit shown in Fig. 3-19 operates on the same principle as the preceding circuit with the exception that the several

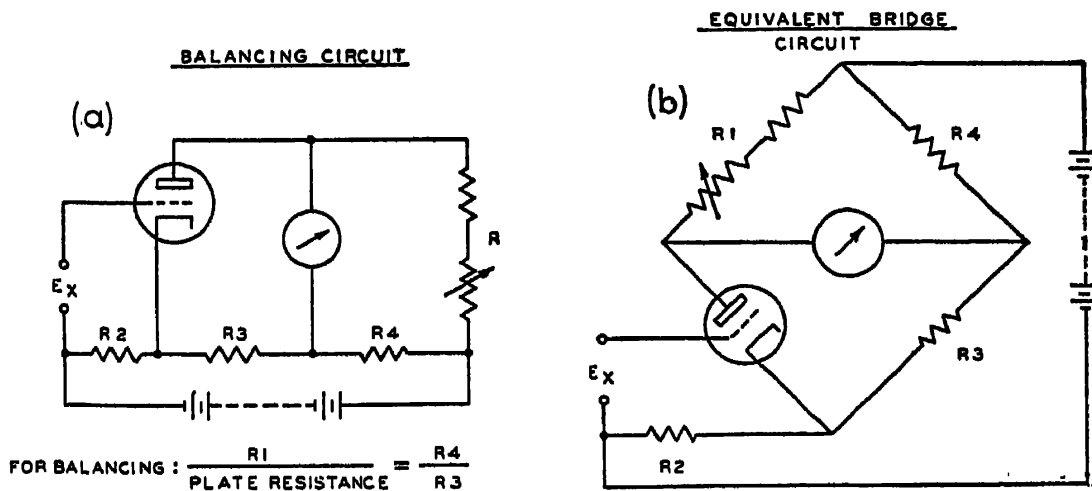

Fig. 3-19. A balancing circuit for use with v-t voltmeters having a voltage divider. The circuit is redrawn at (b) to show the equivalent bridge circuit.

voltages are supplied by means of a voltage divider across a single source of voltage. As the equivalent circuit at (b) shows, the bridge principle still applies, but in this case the second pair of bridge arms are supplied by $R3$ and $R4$ instead of $E1$ and $E2$. A circuit of this type is often used in both a-c and battery-operated v-t voltmeters because of the advantage that all voltages are supplied from a single source. In the case of a-c operated voltmeters, this source can readily be regulated by means of a voltage-regulator tube. The circuit can be modified as shown in Fig. 3-20 for use with battery-operated tubes so that the same voltage source will also supply the filament current.

As in the preceding circuit, the constants should be chosen so that the balancing resistor $R1$ is at least ten times the meter resistance. To prevent loss in sensitivity because of excessive bleeder resistance, the

bleeder resistance should be small enough so that the bleeder current is several times the maximum plate current. For example, if the plate current varies between 2 and 4 milliamperes, then the bleeder current

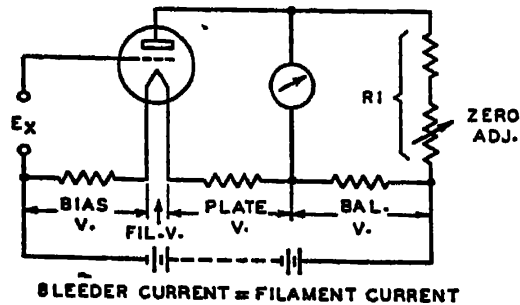

Fig. 3-20. A v-t voltmeter circuit in which the bleeder current supplies the bias, filament, plate, and balancing voltages.

should be from three to five times the 4-milliamperes value—or approximately 12 to 20 milliamperes.

Cathode Balancing Circuits

In some instances it is desirable to place the meter in the cathode circuit rather than in the plate circuit as in the preceding balancing circuits. A representative cathode balancing circuit for use with heater type tubes is shown in Fig. 3-21a. The balancing circuit is in-

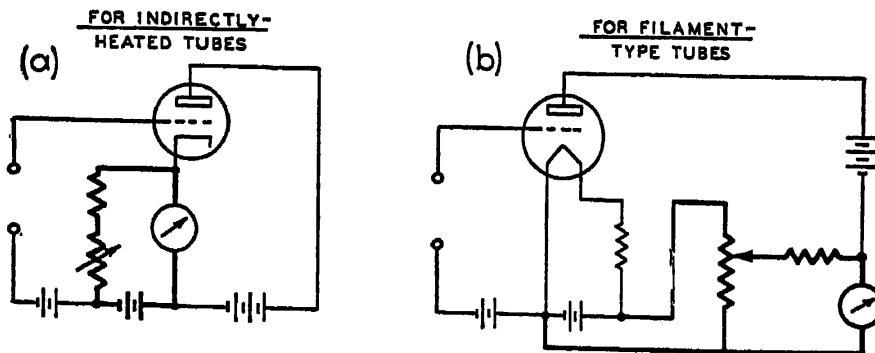

Fig. 3-21. Two balancing circuits which enable placing the meter in the cathode circuit. The circuit at (a) is adapted for indirectly heated tubes, while that at (b) for filament type tubes.

dicated by the heavy lines. To avoid loss in sensitivity the balancing voltage should be large enough so that the balancing resistance will be at least ten times the meter resistance.

Battery operation is not essential in this circuit. For example the batteries can be replaced by a voltage divider. Where this scheme is used the bleeder current should be several times the maximum plate current.

The circuit shown in Fig. 3-21b is designed for use with battery-

operated tubes so that the same battery can be used to supply the filament voltage and the balancing voltage. This circuit was formerly widely used but is no longer very popular.

Two-Tube Bridge Circuit

The two-tube bridge circuit shown in Fig. 3-22 is similar in operation to the conventional balancing circuit which has already been described in connection with Fig. 3-19. The important difference between these two circuits is that one of the arms of the bridge is formed by a tube instead of by a resistor. This use of a tube as a resistor makes the circuit symmetrical so that changes in either filament, plate, or bias

Fig. 3-22. A two-tube v-t voltmeter circuit in which an inactive balancing tube is used to complete the bridge circuit. This type of circuit can be used with any grid-rectification, plate-rectification, or d-c v-t voltmeter.

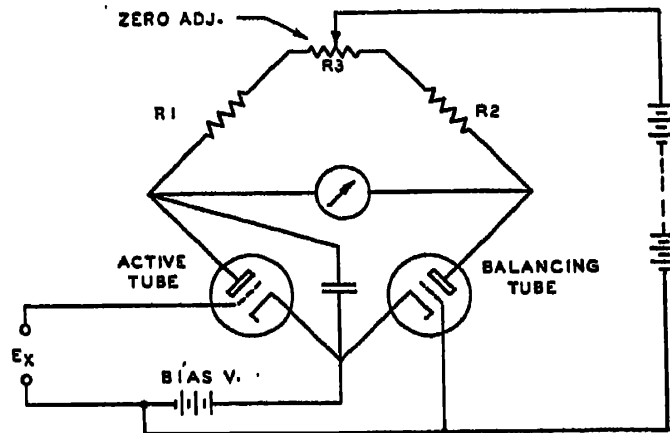

voltages will not cause the zero to drift. This is an important advantage since the time lag accompanying changes in heater voltage makes it very difficult to compensate in any other way for such changes. The two-tube circuit is especially advantageous where a high- μ tube is used since the change in "contact potential" accompanying changes in heater voltage is largely balanced out.

To secure a symmetrical circuit both the active and the balancing tube should be of the same type and preferably should be matched. The values of R_1 and R_2 should be approximately equal so that no current will flow through the meter when no signal is applied. The values of R_1 and R_2 are not critical, and about the only requirement is that they have a value which is at least several times the meter resistance. The use of high values of R_1 and R_2 will not raise the sensitivity appreciably, but will tend to make the calibration more linear because of the higher plate load resistance. Because the resistance of both R_1 and R_2 limits the off-balance current through the meter, the sensitivity of the bridge type of circuit is about one-half that of the single-ended circuit.

The zero-adjustment control R_3 makes it possible to compensate for variations in the characteristics of the two tubes. This control should have approximately one-seventh the resistance of R_1 so as to make possible a smooth adjustment. If there is insufficient latitude to enable the zero adjustment to be made, the two tubes differ too widely in their characteristics and should be replaced with a matched pair.

In ultra-sensitive v-t voltmeters the circuit is often modified by the inclusion of resistances which compensate for slight variations in the plate resistance and amplification factor of the two tubes. In this way perfect symmetry is attained so that the drift in the zero is made negligible. In all ordinary v-t voltmeters these refinements are not required and merely matching the two tubes for equal plate current is sufficient to obtain good stability.

In the interests of simplicity, bypass condensers have been omitted from some of the circuits shown in this chapter. It should be understood, however, that adequate bypassing of the plate and cathode circuits is required in order to prevent a variation in sensitivity with frequency and to permit calibration at 60 cycles.

Chapter IV

SLIDE-BACK VACUUM-TUBE VOLTMETERS

THE slide-back v-t voltmeter has been described in Chapter II in connection with diode v-t voltmeters of this type. Slide-back v-t voltmeters, however, are not limited to types employing diodes and in fact the designation is more usually applied to circuits which employ triodes and screen-grid tubes. In this chapter we shall describe slide-back circuits other than those of the diode type, including their applications, advantages, and limitations.

The Triode Slide-Back V-T Voltmeter

The basic circuit of the triode slide-back v-t voltmeter is shown in Fig. 4-1. This circuit is similar to that of the diode slide-back v-t voltmeter in Fig. 2-16, with the exception that the diode rectifier is replaced by a triode rectifier. As should be expected, the fundamental operation of the two circuits is the same. The replacement of the diode

Fig. 4-1. The basic circuit of the triode slide-back v-t voltmeter.

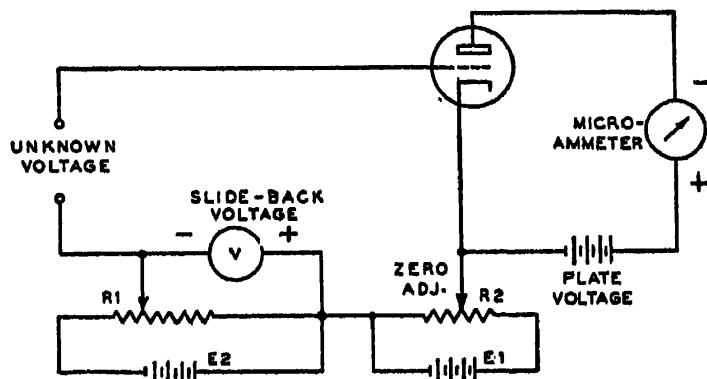

rectifier with a triode rectifier has the advantage of decreasing the loading of the circuit under test and reducing the error at low voltages.

To measure a voltage with the triode slide-back v-t voltmeter, the slide-back voltage is set so that the voltmeter V reads zero. With the input terminal shorted, the zero adjustment R_2 is set so that the plate microammeter reads some small reference value of plate current of the order of 10 to 100 microamperes. To prevent overload

of the meter, the slide-back voltage should now be adjusted by means of $R1$ so that a high negative voltage is applied to the grid. The unknown voltage is then applied to the input terminals and the slide-back voltage adjusted until the plate microammeter reads the initial reference value of plate current previously mentioned. By the same reasoning used in connection with diode-type slide-back v-t voltmeters (see p. 28), it is clear that the positive peak value of the unknown voltage is equal to the slide-back voltage as indicated by the reading of the d-c voltmeter V which measures the slide-back voltage.

The operation of the slide-back v-t voltmeter is illustrated in Fig. 4-2. Here it is shown that the tube is initially biased close to plate current cut-off, the initial bias voltage being provided by $R2$ in Fig. 4-1. When the signal is applied, and the slide-back voltage is adjusted, Fig. 4-2 shows that the same reference value of current is obtained *as a result of plate rectification of the positive peaks of the unknown voltage*. Because these positive peaks are effective in causing plate current to flow for only a small fraction of the cycle, it is clear that the peak plate current required is considerably larger than the average or initial reference value of plate current. This condition, illustrated in Fig. 4-2, explains why slide-back voltmeters have an inherent error which tends to make the slide-back voltage less than the peak voltage being measured.

Error in Slide-Back V-T Voltmeters

It is clear from a study of Fig. 4-2 that the slide-back v-t voltmeter will always indicate a slide-back voltage which is less than the positive peak voltage being measured. This condition arises because a part of the positive peak is "lost" in providing the necessary increase in plate current by plate rectification. The amount of this error is surprisingly large, so much so that ordinarily it should not be neglected when the voltage being measured is less than about 10 volts. As would be expected, the error is greatest for small voltages since the part of the positive peak "lost" in providing plate rectification is then an appreciable percentage of the total peak voltage.

In conventional slide-back circuits employing a triode rectifier, an error of approximately 50% can be expected when voltages of the order of 1 volt are measured; this error increases for voltages lower than 1 volt. As a typical example, the slide-back voltage for a balance condition when a 1-volt peak signal is applied may be only 0.5 volt, so that an error of 50% is present. With the same instrument, the error will be of the order of 15% at a 5-volt level, and proportionately less at higher voltages.

The comparatively large error of slide-back v-t voltmeters can be reduced by plotting a correction curve. Such a curve shows the amount

which must be added to the slide-back voltage in order to obtain the true peak voltage. As a general rule, however, such curves are themselves subject to error because of the rapid variation in rectification efficiency near cut-off. For this reason a correction curve should always be used with a fixed value of reference current. The procedure for making a correction curve is described on page 151.

Input Resistance of the Slide-Back V-T Voltmeter

The input resistance of the triode slide-back v-t voltmeter is considerably higher than that of the diode type since the reference value of plate current is produced without drawing any current from the

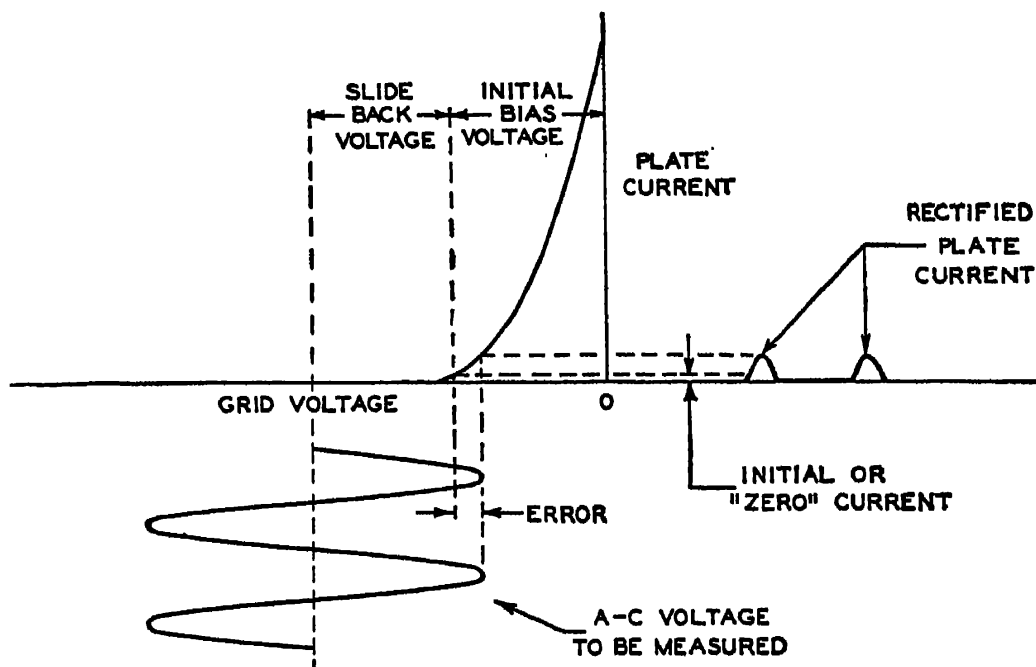

Fig. 4-2. The operation of the slide-back v-t voltmeter. Initially the tube is biased just above plate current cutoff. When the slide-back voltage is adjusted so that it is almost equal to the positive peak of the applied voltage, the initial plate current is restored.

circuit under test. In general the input resistance tends to be somewhat higher than that of most triode plate rectification v-t voltmeters since the grid is excited only for a small fraction of the cycle. Another factor contributing to the high input resistance of the triode slide-back v-t voltmeter is the fact that operation is usually at a plate-current level of several microamperes so that the losses tend to be smaller. The usual considerations governing the input impedance of v-t voltmeters at high frequencies also apply to the slide-back type. It follows that an acorn tube should be used where the high-frequency losses are to be kept to a minimum.

Slide-Back V-T Voltmeter Measures the Positive Peak

As Fig. 4-2 shows, the slide-back v-t voltmeter is essentially a peak voltmeter which measures the positive peak of the applied voltage. Thus it is subject to waveform errors which are characteristic of all peak v-t voltmeters. Ordinarily it is not possible to measure the negative peak of the applied voltage. In the special case where the voltage being measured is ungrounded, however, the negative peak can be measured by merely reversing the connection of the leads to the v-t voltmeter. In measurements on high-impedance circuits, the "low" lead should never be connected to the grid terminal of the slide-back voltmeter since this will cause an error due to cross ground impedances, as explained on page 114.

Measurement of Trough Voltage—The slide-back v-t voltmeter cannot be used for the measurement of trough voltages (see Fig. 2-20) except in the special case where the polarity of the pulsating voltage is *negative*. In such cases, the unknown voltage should be applied to the v-t voltmeter with the negative (ungrounded) lead connected to the control grid of the v-t voltmeter; note that this is the reverse of the usual polarity of connection. The slide-back voltage polarity should also be the reverse of the usual polarity, with the slide-back voltage connected so as to drive the control grid *positive*. A little reflection will make it clear that when the initial reference current is restored, the trough value of the pulsating voltage is equal to the slide-back voltage.

Unfortunately, the above method for measuring trough voltage has a limited application because usually it is not possible to apply the pulsating voltage with the required polarity. For example, in vacuum-tube plate circuits the trough voltage is always positive with respect to ground so that the above method cannot be used. In such instances a diode type slide-back v-t voltmeter can be used to make the measurement as explained in Chapter II. In this connection, the diode circuit is more flexible than the triode circuit in that the cathode and diode plate can be interchanged so as to enable the measurement of peak and trough voltages regardless of polarity.

Preventing Injury to the Meter

Several methods can be used to reduce the danger of overloading the plate microammeter in slide-back v-t voltmeters. These methods, which are illustrated in Fig. 4-3, include (1) the insertion of a resistor R in the grid circuit so as to prevent the grid from being driven positive, (2) the use of a shunt R across the meter during preliminary adjustments, and (3) the use of a high value of resistance R in series with the microammeter.

The use of a high value of resistance in series with the grid, usually about $\frac{1}{4}$ megohm, provides some protection to the meter but is not too effective since the grid voltage must drop to zero before the resistor prevents a further increase in the plate current. In addition to providing only a limited amount of protection, the grid resistor method has the limitation that the sensitivity becomes dependent upon the frequency of the signal. This increases the error at high frequencies, especially for small voltages. The grid-resistor method should not be used at frequencies higher than about 100 kilocycles.

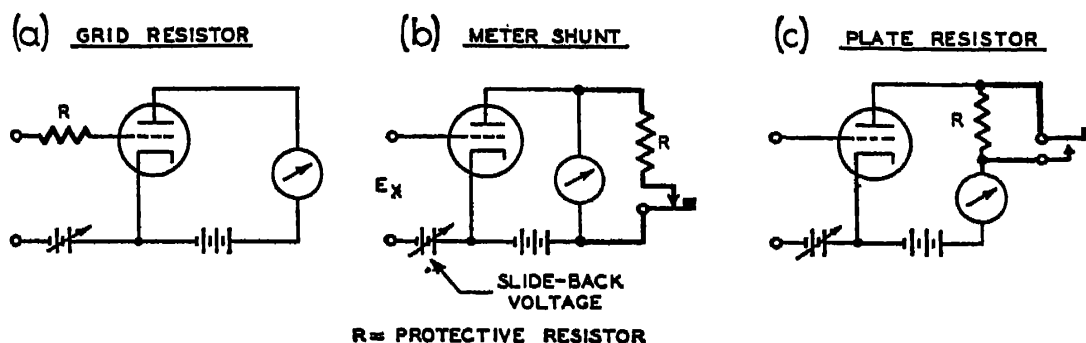

Fig. 4-3. Three methods of reducing the danger of overloading the plate microammeter in slide-back v-t voltmeters. The non-locking push-button switches at (b) and (c) protect the meter at all times except while the final adjustment is being made.

The shunt method shown in Fig. 4-3b is most effective in preventing injury to the plate microammeter when a push-button switch of the non-locking type is used to disconnect the shunt. In this way the meter is unshunted only when the reference value of plate current is being measured and is automatically shunted during all preliminary adjustments. The plate resistor method of reducing the overload current which is shown in Fig. 4-3c is most useful where a sensitive meter is employed and the circuit is designed to be used at a reference plate current of the order of a few microamperes. Under these conditions the plate resistor R can be as high as several megohms.

Where the maximum accuracy is not required, it is not essential that a sensitive microammeter be used to establish the reference value of current. For a great many measurements an 0-1000 microampere meter is entirely satisfactory. The reference value of current should then be about one division on the scale or about 20 microamperes.

Measurement of D-C Voltages with Slide-Back V-T Voltmeter

The slide-back v-t voltmeter can also be used for the measurement of d-c voltages. Almost invariably, however, the measurement can be made more conveniently by other means (see Chapter VIII) which

provide a *direct* indication of the unknown voltage without the necessity for an auxiliary voltage supply.

Where the slide-back v-t voltmeter is to be used for d-c voltage measurements, the instrument should be provided with a polarity switch so that the polarity of the slide-back voltage can be reversed depending upon the polarity of the unknown voltage. If this is positive with respect to ground, the polarity of the slide-back voltage should be such that the grid is made negative. For a voltage which is negative with respect to ground, the polarity of the slide-back voltage should be such that the grid is made positive.

It is worth noting that the plate-rectification error present when a-c voltages are measured does not exist for d-c voltages. When a d-c voltage is measured, it is clear that the slide-back voltage must be exactly equal to the applied d-c voltage in order that the initial reference plate current be restored. For maximum sensitivity, the reference plate current should be considerably higher than for a-c voltage measurements since a large mutual conductance is desired. A convenient reference level is about 250 or 500 microamperes when using a 1000-microampere meter. Usually the accuracy of the slide-back v-t voltmeter for d-c voltage measurements is limited only by the accuracy of the d-c voltmeter used to measure the slide-back voltage. As noted in Chapter VIII, special attention must be given to the tube type and the operating conditions in order to obtain the highest possible input resistance.

Input Circuit of Slide-Back V-T Voltmeters

The same considerations which apply to the input circuits of other types of triode v-t voltmeters also apply to the slide-back type. Where the instrument is used solely for the measurement of a-c voltages, it is recommended that a blocking condenser and grid resistor be used. For the measurement of pulsating and d-c voltages, this blocking condenser must be removed and the unknown voltage connected directly to the grid. In the latter instance, the resistance in the input circuit must be kept constant to prevent any change in the "contact potential."

Space-Charge Slide-Back V-T Voltmeter

The accuracy of the slide-back v-t voltmeter can be increased considerably provided that the conventional triode shown in Fig. 4-1 is replaced with a screen-grid tube in which the screen is used as the control grid, the control grid being connected to the cathode. This type of connection, commonly designated as the *space-charge connection*, has the advantage that the sharpness of the plate-current cut-off is increased several fold. As a result of the steeper slope with which

the plate current approaches the zero axis, the space-charging slide-back v-t voltmeter has a higher plate-rectification sensitivity. Thus a relatively small change in grid bias or a-c voltage produces a comparatively large change in plate current, so that the characteristic error of the slide-back v-t voltmeter is greatly reduced.

A typical slide-back v-t voltmeter using the space-charge connection is shown in Fig. 4-4. With the exception that the screen functions as

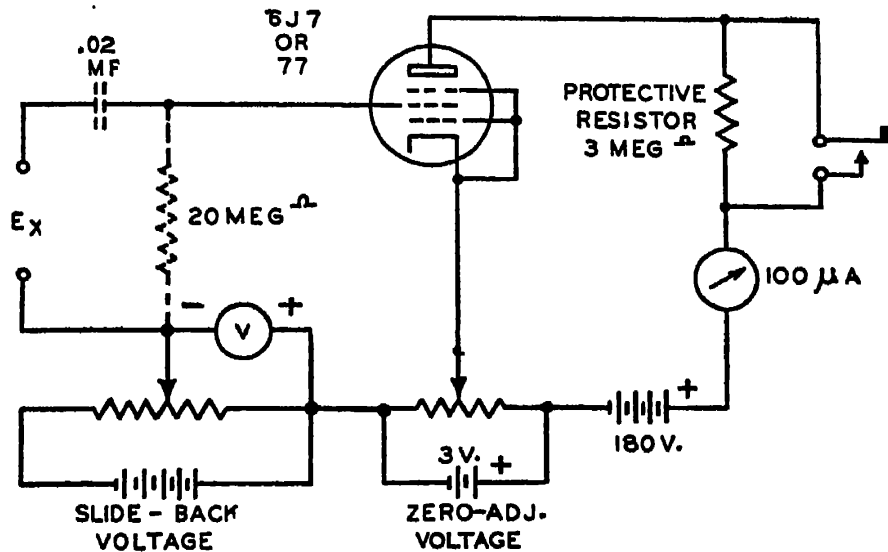

Fig. 4-4. A typical slide-back v-t voltmeter in which the screen grid is used as the control grid. This provides a sharper plate current cutoff so that greater accuracy is obtained in measuring small voltages.

the control grid, this circuit is similar to Fig. 4-1. The comparatively high plate voltage of 180 volts is used in this circuit because low values of plate voltage tend to result in grid current and a lowered value of input resistance; this is especially true when working near cut-off at plate currents of the order of a few microamperes. Otherwise, the plate voltage has practically no effect on the sensitivity since the slope of the plate current-grid voltage curve near cut-off is practically independent of the plate voltage over a very wide range. A protective resistor of about 3 megohms is shown in the plate circuit.

The error which can be expected with this circuit is about one-third that with circuits using the ordinary triode connection. With the constants shown in Fig. 4-2, the error at a level of 0.5 volt is about 35%; at a 1-volt level, the error is about 25%; at a 5-volt level the error is about 7%; and at a 20-volt level the error decreases to about 2%. Although the error is less than for the triode type slide-back v-t voltmeter, the above figures show that it is advisable to use a cor-

rection curve for all voltage measurements lower than about 5 or 10 volts.¹

Amplifier Type Slide-Back V-T Voltmeter

It is possible to replace the plate microammeter in the slide-back v-t voltmeter with a d-c amplifier. Where this arrangement is used, a high value of resistance is inserted in the plate or cathode circuit and the d-c voltage developed across this resistor is fed to the d-c amplifier.

A circuit of this type is shown in Fig. 4-5, which uses a reflex or self-biased type of rectifier. Approximately 3 volts is developed

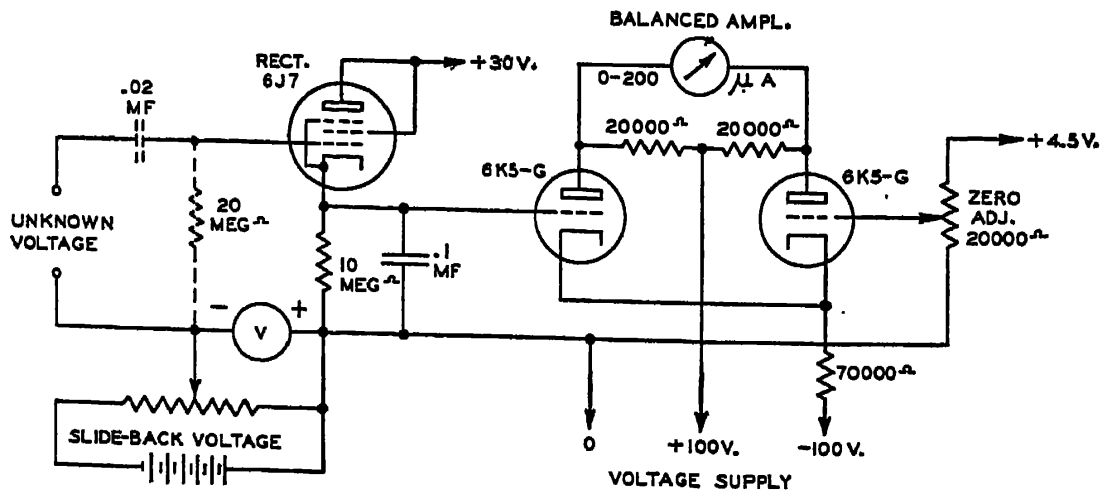

Fig. 4-5. An amplifier type of slide-back v-t voltmeter in which the conventional plate microammeter is replaced by the 10-megohm cathode resistor. The reference value of plate current is observed indirectly by measuring the voltage drop across the cathode resistor by means of the balanced d-c v-t voltmeter.

across the 10-megohm cathode resistor when no signal is applied so that the reference value of plate current is about 0.3 microampere. When a signal is applied plate rectification takes place and the voltage at the cathode becomes more positive. This upsets the balance of the d-c amplifier so that the microammeter connected across the plates of the two amplifier tubes provides a measure of the change in the rectified plate current.

Although more complex than the conventional slide-back circuit, this circuit has the advantage that the microammeter current is limited to about 500 microamperes so that the meter cannot be injured. At the same time the input resistance is appreciably higher than for the

¹ Aiken, C. B. and Birdsall, L. C., "Sharp Cutoff in Vacuum Tubes with Applications to the Slide-Back Voltmeter." Elec. Engineering, Apr. 1938, p. 171.

conventional slide-back circuit as a result of the exceedingly small value of plate current. There is no appreciable difference in sensitivity between this and the conventional plate-rectification circuit of Fig. 4-1.

Because of the high stability of the circuit employed in Fig. 4-5, a direct calibration can be used for voltages less than several volts. That is, the deflection of the microammeter can be calibrated directly in terms of the a-c voltage applied to the input terminals of the rectifier. When this procedure is used, the instrument is no longer a slide-back v-t voltmeter, but becomes essentially a rectifier-amplifier v-t voltmeter (see Chapter V).

Chapter V

RECTIFIER-AMPLIFIER VACUUM-TUBE VOLTMETERS

FUNDAMENTALLY all a-c v-t voltmeter measurements depend upon rectification of the a-c voltage so that it can be determined in terms of a d-c current or voltage. As mentioned earlier, the advantage of rectifying the a-c voltage is that it permits the use of d-c instruments which are more sensitive, more accurate, and less expensive than a-c instruments. At the same time, the conversion of the unknown a-c voltage into a d-c voltage has the important advantage of enabling measurements to be made over a very wide range of frequency.

In the v-t voltmeters described in the preceding chapters, a basic rectifier stage is used with the d-c meter inserted so as to measure the rectified plate current. In none of these circuits has there been any attempt to amplify the d-c output of the rectifier. By adding a d-c amplifier stage as shown in Fig. 5-1, however, the performance can

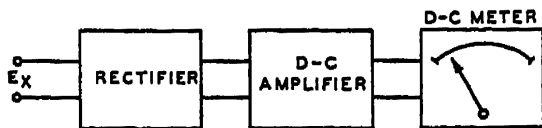

Fig. 5-1. A block diagram of the rectifier-amplifier type of v-t voltmeter.

be greatly improved. Provided the circuit is properly designed, the addition of the d-c amplifier has the advantage of providing higher sensitivity, greater stability, a wider range, and, in certain instances, higher input impedance. These advantages can be realized because the separation of the functions of rectification and amplification make it possible to obtain the greatest efficiency in each of these two functions.

The rectifier-amplifier type of v-t voltmeter is particularly adapted for use with the probe type of construction. As is illustrated in Figs. 3-16 and 5-8, this type of construction has the advantage of permitting extremely short leads to the circuit under test. In practice the rectifier tube is usually mounted in a small shielded assembly at the end of a flexible or "goose-neck" cable. Since the leads from the rectifier to the d-c amplifier and power-supply unit carry only d-c and 60-cycle voltages, this cable may have any desired length.

Diode Rectifier Used with D-C V-T Voltmeter

In some instances a d-c v-t voltmeter is available which covers a range of voltages extending from a fraction of a volt up to several hundred volts. A considerable number of instruments of this type (described in Chapter VIII) are in use, many of them being multi-range d-c v-t voltmeters and ohmmeters. Such instruments can be

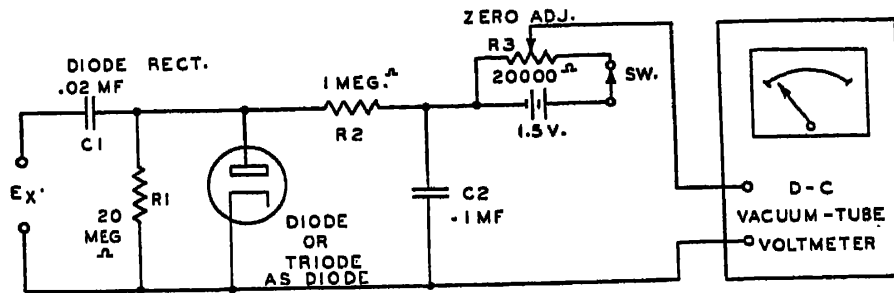

Fig. 5-2. A d-c v-t voltmeter can be adapted to read a-c voltages by the addition of a diode rectifier circuit. For high frequency work, the diode should be mounted in a probe.

adapted for the measurement of a-c voltages by the addition of a rectifier unit to convert the a-c voltage into a d-c voltage. Circuits for accomplishing this are shown in Figs. 5-2 and 5-3.

The circuit in Fig. 5-2 employs a shunt type of diode rectifier which is similar to the diode rectifier described on page 20. Because the rectifier output is taken off in the form of a voltage rather than a current, it is possible to use a high load resistance. In the diode circuits shown in Chapter II, on the other hand, high values of diode resistance cannot be used because the effect is to reduce the current output. In the rectifier-amplifier circuit the voltage output is actually *increased* by using high values of load resistance.

The d-c voltage developed at the diode plate is fed to the d-c v-t voltmeter through a filter circuit consisting of R_3 and C_2 . This filter removes the a-c component of the voltage present at the diode plate, so that the voltage at the output of the filter contains only the d-c component. As explained on page 19, this voltage is slightly less than the peak a-c voltage at the input to the rectifier.

It will be recalled that with no signal applied to the rectifier the "contact potential" at the diode plate is approximately 1 volt (see Fig. 2-13). It is desirable to balance out this negative voltage since otherwise a comparatively large zero-signal deflection will be obtained on the d-c v-t voltmeter. A convenient method for balancing the contact potential is to use a flashlight cell shunted with a 20,000-ohm potentiometer as indicated in the figure. A switch should be included to prevent a permanent drain on the cell when the rectifier is not in use. To make the necessary adjustment the d-c v-t voltmeter zero

adjustment should first be made in the usual manner with the rectifier disconnected. The filter output should then be connected to the d-c v-t voltmeter, and the control $R3$ adjusted so that a zero reading is again obtained. This adjustment should not be made until the rectifier tube has had sufficient time to heat since the adjustment depends upon the emission of the rectifier tube.

Although the diode load resistor $R1$ can be made as high as 50 megohms, the filter resistor $R2$ should not be larger than about 1 megohm, if there is not to be an excessive loss in sensitivity. From an inspection of Fig. 5-2 it is apparent that $R2$ forms a voltage divider in combination with the input resistance of the d-c v-t voltmeter so that only a fraction of the voltage developed at the diode plate reaches the d-c v-t voltmeter. For example, if $R2$ is 1 megohm and the input resistance of the d-c v-t voltmeter is 10 megohms, then 10/11 or about 90% of the rectified voltage reaches the d-c v-t voltmeter. For radio-frequency measurements the best value for $R1$ is about 1 megohm. This gives an input resistance which is of the order of 1 megohm and at the same time keeps the reduction in sensitivity at a negligible value. If higher values of $R2$ are used, the input resistance will be raised only slightly, but the sensitivity will be lowered appreciably.

For voltages below about 10 volts, a direct calibration is required because of the non-linearity of rectification at low voltages. On the higher voltage ranges, however, the a-c peak voltage will be approximately equal to the d-c voltage indicated by the v-t voltmeter, with allowance being made for the reduction in sensitivity due to the d-c drop across the filter resistor $R2$. The most convenient method for reading voltages higher than about 10 volts is to determine the multiplying factor required to give the peak or rms voltage.

Reflex Rectifier Used with D-C V-T Voltmeter

The reflex or self-bias rectifier circuit shown in Fig. 5-3 has several important advantages over the diode circuit just described. The foremost of these advantages is that the input impedance is much higher than for the diode circuit. Because the filter circuit is an integral part of the rectifier, no reduction in sensitivity takes place in the filter circuit. Thus the a-c component of the rectified voltage is completely removed by the cathode bypass condenser $C1$. When used with an external d-c v-t voltmeter as in this circuit, the reflex rectifier has the disadvantage that plate voltage is required. This voltage must be somewhat greater than the highest peak voltage to be measured.

The operation of the reflex rectifier has already been described on page 51 in connection with the self-bias or reflex plate-rectification v-t voltmeter. The operation of the rectifier shown in Fig. 5-3 is basically the same as that of the circuit referred to above. However,

the constants are chosen so that the maximum rectified *voltage* rather than *current* will be produced. Thus the cathode resistor $R1$ in the present circuit is 10 megohms as against the much lower values used in the circuits shown in Chapter III. Since the high value of cathode resistance is bypassed by a large condenser $C1$, this condenser charges up to a voltage which is slightly lower than the peak value of the a-c signal impressed on the grid. The fact that there is no amplification in this circuit is no disadvantage since the necessary amplification is provided by the d-c v-t voltmeter. The high degree of stability and the high value of input impedance which are achieved as a result of triode operation with low plate current more than compensate for the required plate voltage and the lack of amplification.

As in the diode rectifier circuit, it is necessary to provide an auxiliary battery to balance out the zero-signal cathode voltage. The circuit

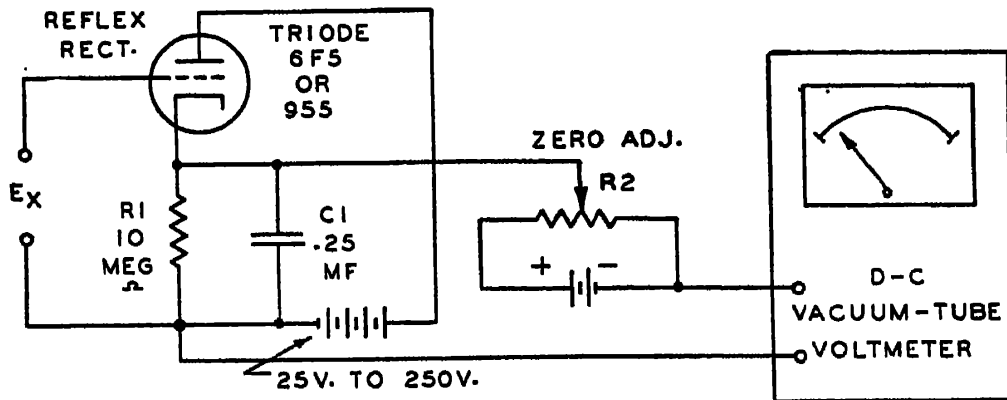

Fig. 5-3. A d-c v-t voltmeter can be adapted to read a-c voltages by the addition of a reflex rectifier which may be mounted in a probe unit for high-frequency measurements.

connections for this are shown in Fig. 5-3. The required battery voltage will vary from a few volts up to about 25 volts depending upon the tube type and the plate voltage.

For average operation a plate voltage of about 200 volts is satisfactory. This will permit operation up to at least 100 volts rms. For deflections less than about 1 volt, improved sensitivity will be obtained by using a plate voltage of the order of 25 volts. Although a still lower plate voltage will improve the sensitivity slightly, its use is undesirable since it will result in grid current and reduced input impedance.

The reflex rectifier circuit shown in Fig. 5-3 is not critical of tube type because of the high value of cathode resistance. Thus triodes having either a high or low amplification factor will function very satisfactorily. In general, however, triodes having a high amplification factor are more suitable where the greatest sensitivity is desired. The lower cut-off voltage of these tubes has the desirable effect of improving

the sensitivity for values of signal voltage of the order of several tenths of a volt and at the same time reduces the zero-signal voltage at the cathode. The latter reduction is desirable since it improves the stability of operation.

For average conditions the circuit constants shown in Fig. 5-3 are suitable. The type 6F5 tube is satisfactory for operation at low frequencies, while the type 955 acorn tube is suggested for use at high radio frequencies where the losses and input capacitance must be kept to a minimum. The probe type of construction is recommended regardless of whether an acorn tube is used.

Rectifier-Amplifier V-T Voltmeter Using a Voltage Divider

The rectifier-amplifier circuit shown in Fig. 5-4 has been rather widely used because of its comparative simplicity and ease of design. Essentially the circuit is similar to that shown in Fig. 5-2 with the exception that the separate multi-range d-c v-t voltmeter is replaced by a voltage divider and a fixed-gain d-c amplifier stage which form an integral part of the complete instrument.

All the elements of this a-c rectifier-amplifier v-t voltmeter have already been described so that only a brief discussion is required here.

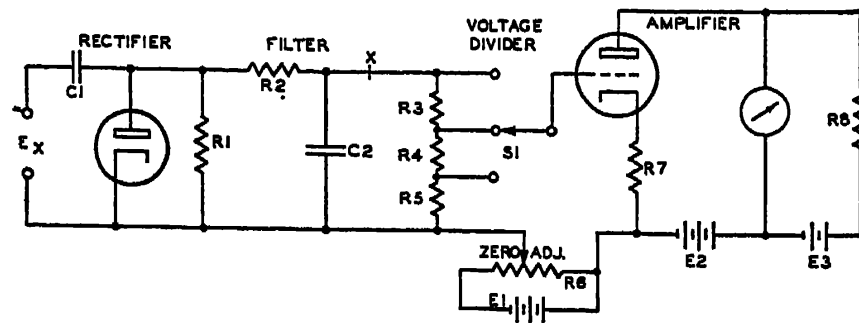

Fig. 5-4. A multi-range rectifier-amplifier v-t voltmeter in which the several ranges are obtained by means of a high-resistance voltage divider in the output of the diode rectifier.

The diode rectifier is conventional, the condenser $C1$ charging up to slightly less than the peak value of the voltage being measured. This voltage is fed through the filter $R2-C2$ into the voltage divider $R3-R4-R5$. The voltage which reaches the grid of the d-c amplifier stage is controlled by the multiplier switch $S1$. The d-c amplifier stage works at a fixed value of plate current which is determined by the resistor $R8$ and the balancing voltage $E3$.

As mentioned earlier, a negative voltage of approximately 1 volt will be applied to the d-c amplifier because of the "contact potential" of the

diode rectifier. Because the voltage divider in the input circuit reduces the contact potential as well as the rectified voltage, it is clear that the operating bias will be different on the several ranges. To compensate for this varying voltage the bias control R_6 , designated as the zero adjustment, must be readjusted on each of the range positions. The major change in this adjustment will occur when the switch is moved from the most sensitive range to the adjacent range.

To eliminate the necessity for readjustment of the zero on each of the ranges, the zero adjustment may be placed in the high side of the grid lead at point X. Although this latter arrangement eliminates the shift in the zero, it has the disadvantage that it is not adapted to a-c power supply operation. A flashlight cell can be used to supply the required balancing voltage.

The values of the circuit components depend upon the requirements. In general, R_3 should be small in comparison with the voltage-divider resistance in order to avoid excessive loss in sensitivity. The high-resistance voltage divider presents somewhat of a problem since several of these resistors, including the filter resistor, are of the order of megohms. Thus wire-wound units cannot be used because of the high values of resistance. The usual arrangement is to employ metallized resistors which can be obtained in high values at nominal cost. These resistors can be paired as explained on page 139 in order to obtain a nominal accuracy of about 1%. In practice, however, the voltage-divider accuracy cannot be relied on to an accuracy greater than a few percent because of temperature variations and changes in resistance with ageing.

As compared with the degenerative amplifier circuit described in the following section, this circuit has the disadvantage that the amplifier works at maximum gain regardless of the voltage being measured. The loss in sensitivity due to the drop through the filter resistor and the necessity for compensating for the variable zero shift are further disadvantages of this circuit. In favor of the circuit it should be noted that the use of a voltage divider simplifies the design of the d-c amplifier which does not require any changes as the range switch is varied.

The reflex rectifier shown in Fig. 5-3 can also be used with this type of circuit and enables a voltage divider of comparatively low resistance to be employed. A total resistance as low as 50,000 ohms can be used, although a resistance of the order of 1 megohm is preferable. The advantages of the reflex rectifier are its higher input resistance and the fact that wire-wound resistors can be employed in the voltage divider. The reflex rectifier, on the other hand, requires a plate-voltage supply which is not needed with the diode rectifier. The latter requirement is not usually an important disadvantage since the plate supply of the d-c amplifier can often be used for the rectifier as well.

Rectifier-Degenerative Amplifier V-T Voltmeter

Another basic type of rectifier-amplifier v-t voltmeter is shown in Fig. 5-5. This differs from that of the preceding circuits in that no voltage divider is employed, but instead the various ranges are secured by controlling the sensitivity of the d-c amplifier. This control in sensitivity is secured by means of a variable resistance in the cathode circuit of the d-c amplifier tube. The larger the value of this cathode resistance, the greater is the degeneration introduced and hence the greater is the input voltage required for full-scale deflection. This type of amplifier is described in detail in the chapter on d-c v-t voltmeters.

In the circuit shown in Fig. 5-5, the sensitivity is controlled by means of the range switch $S1$. This two-section switch is so ganged

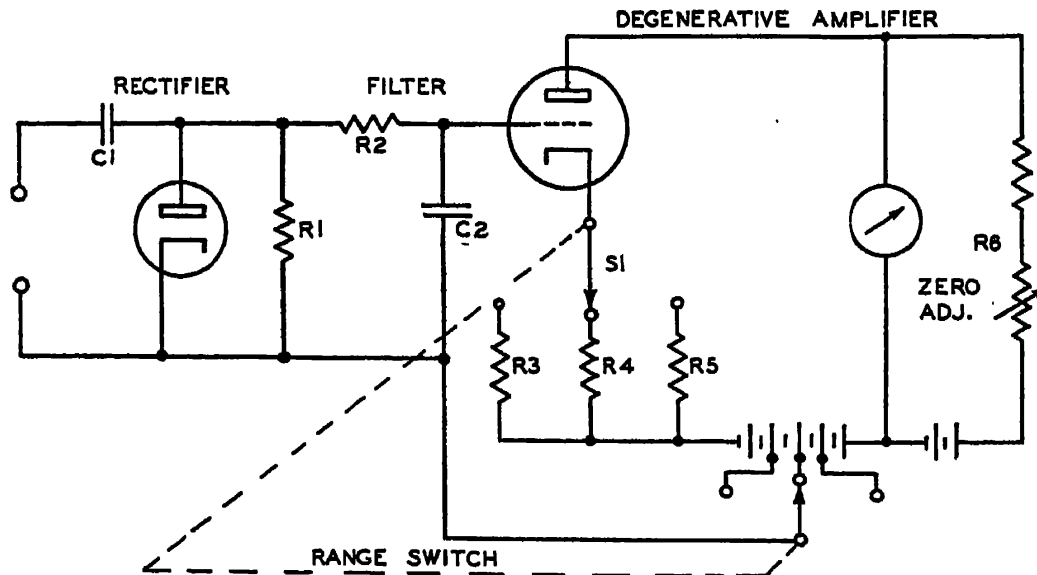

Fig. 5-5. The basic circuit of an a-c v-t voltmeter using a diode rectifier and a degenerative d-c amplifier. The various ranges are secured by means of the switch $S1$ which varies the cathode resistance and at the same time controls the bias voltage so as to maintain a constant plate current.

that the bias voltage is changed simultaneously with the change in the cathode resistance. By returning the cathode to the proper point on the voltage divider in this way, the same initial plate current and the same operating point is secured on all ranges. On the higher voltage ranges where values of cathode resistance of the order of several hundred thousand ohms are used, full-scale deflection will be secured for an input of about 100 volts. Under these conditions, the cathode must be returned to a point on the voltage divider which is quite negative with respect to the grid-return point. This large negative voltage is

required in order to balance out the comparatively large voltage drop across the cathode resistor. Where the cathode resistance is very large, the change in plate current is approximately equal to the applied grid voltage divided by the cathode resistance. Thus the deflection becomes independent of the tube voltages and the tube characteristics, so that a high degree of stability is secured.

In addition to providing stability and permanence of calibration, the degenerative amplifier circuit has the advantage that a high-resistance voltage divider is not required. Since the cathode resistors R_3 , R_4 , and R_5 which control the sensitivity are all less than a few hundred thousand ohms, wire-wound resistors can be used.

An important feature of the degenerative amplifier circuit results because the amplifier works at a gain which is reduced proportionately as the range of the instrument is increased. This not only improves the stability but also tends to prevent excessive current through the meter if overload takes place. At the same time the degenerative action improves the linearity on the higher ranges where large values of cathode resistance are used.

The degenerative type of amplifier circuit can also be used in combination with the reflex rectifier. As in the previous circuits, the reflex rectifier has the advantage over the diode rectifier of higher input impedance, but the disadvantage that plate voltage must be supplied.

General Radio 726-A V-T Voltmeter

The General Radio Model 726-A v-t voltmeter is an example of a commercial instrument utilizing the rectifier-amplifier principle. A simplified circuit of this v-t voltmeter is shown in Fig. 5-6 and a com-

Fig. 5-6. The basic circuit of the General Radio 726-A v-t voltmeter which uses a diode rectifier and a degenerative d-c amplifier.

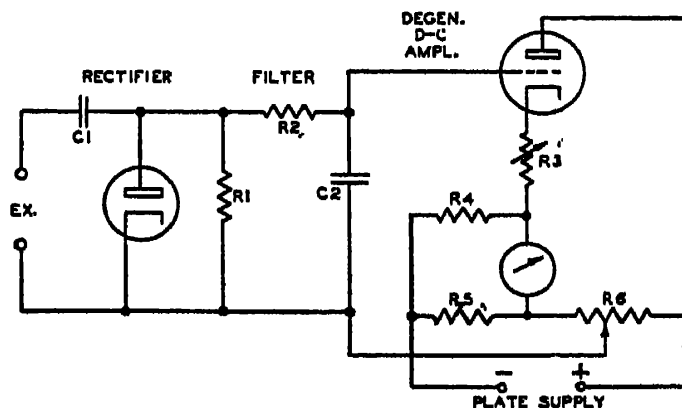

plete schematic of the instrument appears in Fig. 5-7. The construction of the probe and the scale layout are shown in Figs. 5-8, 5-9. Voltages can be measured up to a maximum value of 150 volts rms. This range is covered in five steps having the following full-scale values:

1.5, 5, 15, 50, and 150 volts. The instrument is a-c line operated from an internal voltage-regulated power supply. The tubes used are a 955 acorn tube as the diode rectifier, a type 6Q7-G as the d-c amplifier, and a type 1-V rectifier.

A simplified diagram of the voltmeter is shown in Fig. 5-6. The diode rectifier circuit is conventional and similar to those previously described. The d-c voltage developed at the diode plate is fed to the degenerative amplifier which is similar to that shown in Fig. 5-5, with

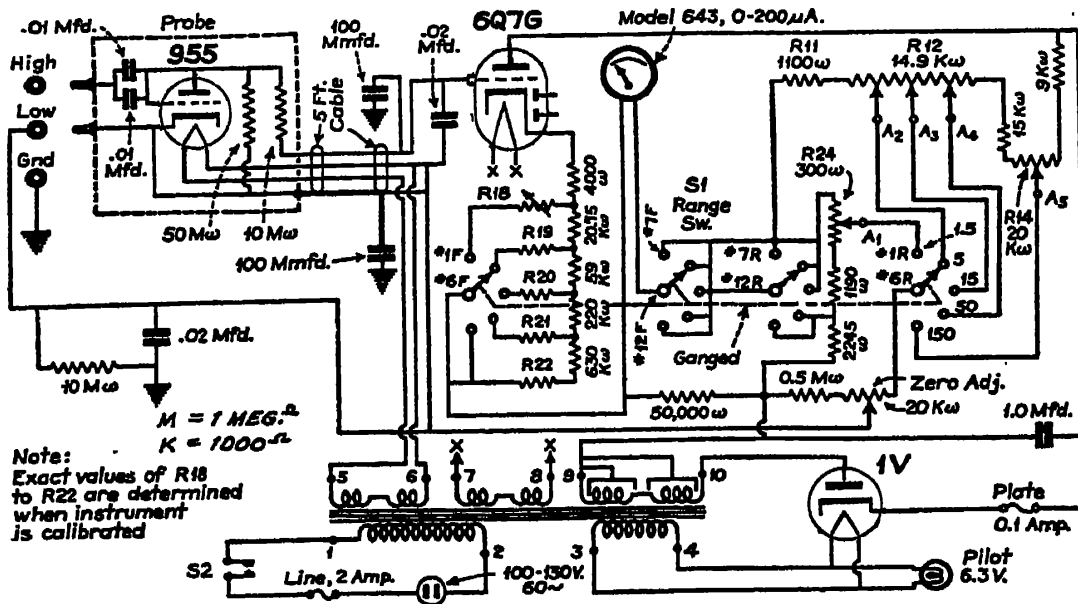

Courtesy of General Radio Co.

Fig. 5-7. The complete schematic of the General Radio 726-A v-t voltmeter. The basic circuit is shown in Fig. 5-6.

the exception that the meter and balancing circuit are placed in the cathode rather than in the plate circuit. The several ranges are secured by varying the value of the cathode resistance $R3$. The operating point is kept constant by means of the potentiometer $R6$ which changes the bias to compensate for the voltage drop across $R3$. The

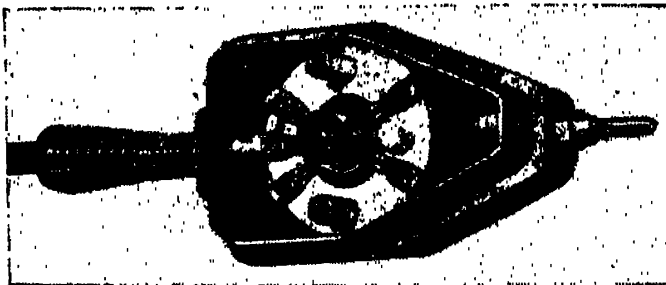

Fig. 5-8. The probe unit of the General Radio 726-A v-t voltmeter showing the manner in which the 955 acorn tube is mounted.

Courtesy of General Radio Co.

balancing current is supplied by means of the resistors $R4$ and $R5$. All voltages are obtained from the output of a half-wave rectifier.

The complete schematic of the instrument is shown in Fig. 5-7. Although this schematic appears more complex than the basic circuit, this complexity is due merely to the inclusion of the resistors and switching required to secure the five voltage ranges. Complete voltage regulation is secured by using a voltage-regulating transformer. This has the advantage that the heater voltages as well as the plate voltages are controlled. This is particularly important in the rectifier-amplifier type of v-t voltmeter because the "contact-potential" voltage is very sensitive to variations in the heater voltage.

The overload current in this circuit arrangement is limited to the operating plate current since the effect of an overload is to apply a more *negative* voltage to the grid of the amplifier tube. The instrument is designed so that a voltage strong enough to cut off the plate current will not cause any damage to the meter.

Fig. 5-9. The scale of the General Radio 726-A v-t voltmeter, the schematic of which appears in Fig. 5-7. Five ranges extending from 1.5 volts to 150 volts full scale are provided.

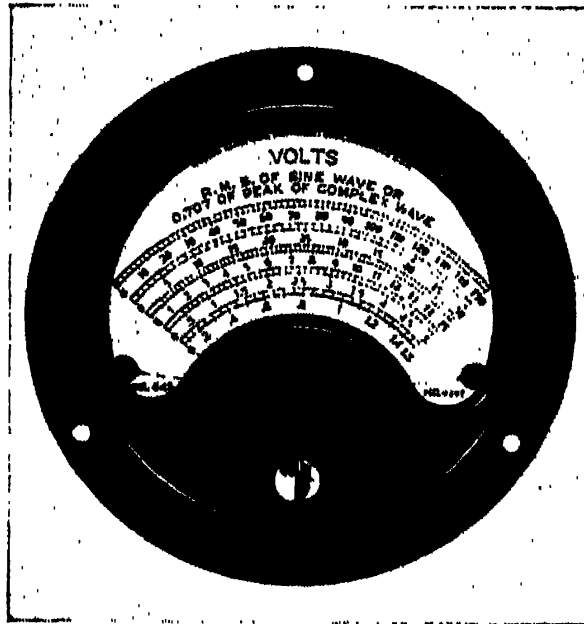

Courtesy of General Radio Co.

The excellent performance of this instrument at high frequencies is due to the use of an acorn tube and the probe type of construction which minimizes the length of lead between the diode and the circuit under test. At 100 megacycles the frequency error is approximately 3%. At higher frequencies the error increases until at 350 megacycles resonance takes place in the input loop. By removing the two banana plugs so as to shorten the length of the input loop, the resonant frequency is raised to about 500 megacycles.

At low frequencies the input resistance is approximately 6 megohms. This input resistance is determined by the losses in the diode circuit, since the current required to charge the input condenser must come from the circuit under test. The input capacitance is about 6 mmf. As a result of the losses in the coupling condenser, in the envelope

and socket of the acorn tube, and the material surrounding the diode resistors R_1 and R_2 , the power factor of this 6-mmf capacitance is approximately 2.5%. At high radio frequencies the input impedance remains the same regardless of whether voltage is applied to the heater of the diode. This shows that at high frequencies "electronic" losses in the diode itself are negligible in comparison with the "dielectric" losses mentioned above.

Provision is made on this instrument so that the probe can be mounted inside the cabinet for low-frequency measurements. When this is done, the voltage under measurement can be connected directly to binding posts provided on the panel.

The LOW input terminal is not connected directly to the panel, but is isolated from it by means of a 0.02-mf blocking condenser and a 10-megohm resistor. This arrangement has the advantage of making it possible to ground the instrument for all measurements, even when the LOW terminal is connected to a point which is not at ground potential. A typical example where this feature is useful is in the measurement of the voltage across the tuned circuit in the plate circuit of a tube.

Although this instrument is essentially a peak-reading v-t voltmeter, for convenience the scale is calibrated in terms of the rms value of the wave. As in all peak reading v-t voltmeters, an error will be encountered when measuring a distorted waveform. This error may be as large as the percentage of the harmonics present in the wave. Regardless of the distortion present, however, the peak value of the measured voltage will be equal to the reading of the meter multiplied by 1.41.

Chapter VI

TUNED VACUUM-TUBE VOLTMETERS

IN THE preceding chapters we described both *rectifier* and *rectifier-amplifier* types of v-t voltmeters. In these instruments no attempt is made at amplification of the voltage under measurement *before* rectification. Where amplification is used, it is limited to d-c amplification following the rectification of the voltage being measured. There are, however, v-t voltmeters in which the voltage under measurement is amplified *before* it is rectified. Instruments of this type can conveniently be classified as *amplifier-rectifier* v-t voltmeters. Included in this classification are "signal-tracing" instruments which are used to check the progress of the signal through a radio receiver. Such instruments invariably must have a considerable amount of amplification so as to make possible measurement of the relatively weak signal levels in the first stages of the receiver.

The signal-tracing v-t voltmeter is essentially a *tuned* v-t voltmeter which is tuned to distinguish between voltages of different frequencies in the same manner as a conventional receiver. The need for selectivity in signal tracing is obvious. For example, in checking the r-f signal level in the input to the mixer stage, it is necessary to have some means of differentiating between the relatively weak r-f signal and the strong oscillator signal.

Amplifier-rectifier v-t voltmeters are by no means limited to the tuned type discussed above. On the contrary, there are many v-t voltmeter applications where it is possible to use *untuned* resistance-coupled amplifiers preceding the rectifier. For the most part, however, the untuned amplifier type of v-t voltmeter is limited to comparatively low frequencies below about 100 kilocycles. At higher frequencies it is not feasible to use untuned amplifiers because the gain falls off very sharply as the frequency is increased. Since untuned amplifier-rectifier v-t voltmeters are limited to low frequencies and find their greatest application in audio-frequency v-t voltmeters, we shall describe this type in the next chapter which deals with audio-frequency v-t voltmeters.

Basic Tuned V-T Voltmeter

A block diagram of the basic structure of a tuned v-t voltmeter is shown in Fig. 6-1. Usually a multiplier or some form of attenuator is provided in the input circuit of the v-t voltmeter. The output of the multiplier is fed to a tuned amplifier, which consists of one or more stages of tuned r-f amplification. The output of the tuned amplifier is then rectified and the rectified voltage indicated by some

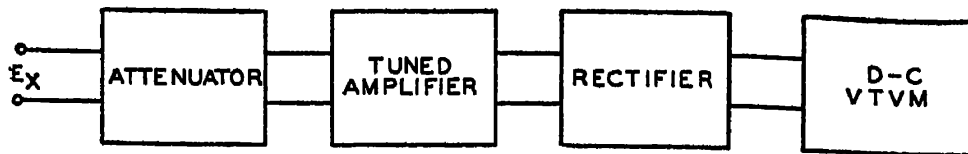

Fig. 6-1. A block diagram showing the structure of the tuned-amplifier type of v-t voltmeter.

form of d-c v-t voltmeter. For operation at frequencies above about 2 megacycles, the tuned amplifier may be of the superheterodyne type, although for lower radio frequencies the tuned r-f amplifier is preferable.

Input Circuit and Probe

In many applications involving the use of tuned v-t voltmeters it is desirable to reduce the input capacitance to approximately 1 micromicrofarad. To obtain an input capacitance as small as this, it is clear that the input circuit cannot be connected directly to the grid

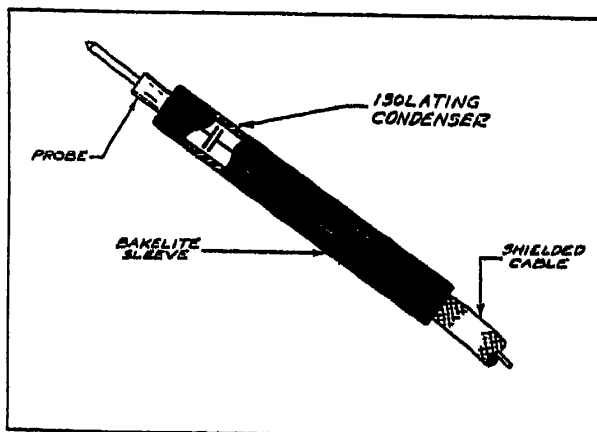

Fig. 6-2. A type of probe which is used with tuned-amplifier v-t voltmeters. The input capacitance is reduced by means of the air gap near the probe tip.

of the first amplifier tube because the input capacitance of the tube alone is considerably greater than 1 mmf, even where an acorn type of tube is used. To overcome this difficulty special probes have been

developed which enable a considerable reduction in the input capacitance. One probe of this type is shown in Fig. 6-2. The input capacitance of such a probe can be made less than 1 mmf. An input capacitance appreciably less than this is difficult to obtain because the capacitance of a small probe tip by itself is of the order of 0.5 mmf.

As Fig. 6-2 shows, the low input capacitance is secured by means of a small condenser which is located close to the probe tip, and is formed by the gap between the probe tip and the inner conductor of the shielded probe cable, which connects to the control grid of the amplifier tube. The complete probe assembly is shielded so that direct pickup to the inner conductor is minimized.

Multiplier

This type of probe and shielded cable is often used in conjunction with a capacitive type of attenuator in the input circuit to the first amplifier tube. A typical circuit of this type is shown in Fig. 6-3; this

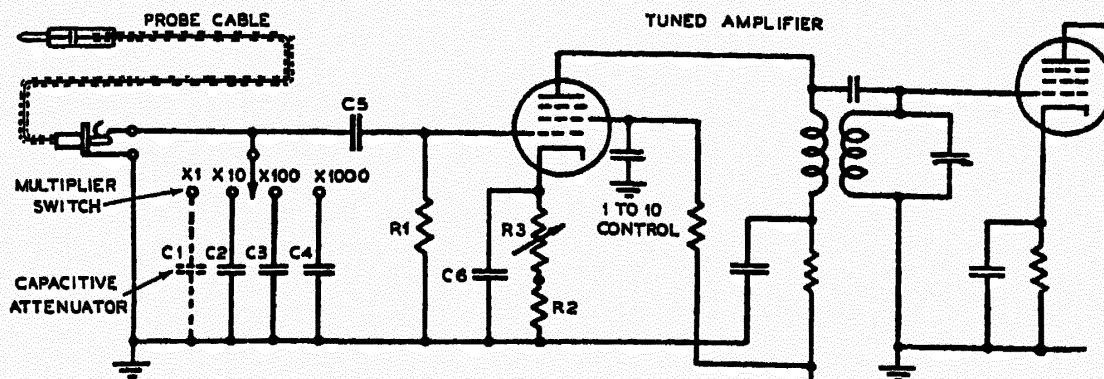

Fig. 6-3. The input circuit of a tuned-amplifier type of v-t voltmeter. The attenuator consists of a multiplier switch which provides attenuation factors in steps of 10, and the cathode control which provides continuous attenuation over a range from 1 to 10.

is similar to the circuit employed in the RCA-Rider Chanalyst. On the X1 position of the multiplier switch, a small trimmer may be connected across the input circuit so as to bring the total input capacitance up to some specific design value of the order of 70 mmf. This total capacitance includes the capacitance of the shielded cable, the input capacitance of the tube, and the wiring capacitance. For the case where the probe input capacitance is 1 mmf and the total capacitance between the grid and ground of the first tube is 70 mmf, it follows that the attenuation in the input circuit would be 70. In other words, only 1/70 of the signal fed to the input of the probe reaches the grid of the first amplifier tube.

On the X10 position of the multiplier switch, the condenser C2 adds

enough capacitance to the input so as to bring the total grid-ground capacitance to 700 mmf, or ten times the previous value. As a result the attenuation is raised to 700 or ten times the attenuation for the *X1* position. In the same way the condensers *C3* and *C4* bring the total capacitance up to 7000 and 70000 mmf respectively, so that multiplying factors of 100 and 1000 are provided by these positions of the multiplier switch.

The attenuation in the input circuit on the *X1* position depends upon the grid-ground capacitance in the input circuit. To keep this attenuation low, the grid-ground capacitance must be kept as small as possible. For this reason it is desirable to use shielded cable of the low-capacitance type for the probe cable; the layout and wiring in the input circuit should be such that the grid-ground capacitance is kept to a minimum. In practice, using ordinary receiving tubes, it is possible to keep the input capacitance down to the order of 70 mmf, so that the input attenuation with a 1-mmf coupling condenser is approximately 70. This figure includes the capacitance of about 3 feet of low-capacitance shielded cable which makes up the major portion of the total capacitance. In certain applications where the input attenuation on the *X1* position must be kept down to the absolute minimum, the use of an acorn input tube, large diameter, low-capacitance shielded cable, and a special low-capacity plug and jack (or a direct connection of the probe) will enable an appreciable reduction in this figure of 70 mmf.

An important feature of the capacitive type of multiplier is its wide frequency range. Thus the division of the voltage depends on the ratio between the probe-tip capacitance and the total grid-ground capacitance. Since this ratio is independent of frequency, the attenuation is also independent of frequency over a wide frequency range. Above about 2000 kilocycles, however, the distributed inductance of the probe cable and the lead inductance to the larger condensers in the multiplier give rise to resonant effects which limit the frequency range to about 2000 kilocycles. To extend the frequency range above this value, the superheterodyne type of amplifier can be used. With the superheterodyne circuit the most suitable location for the attenuator is in the input circuit of the first i-f stage. The same type of capacitive multiplier may be employed since operation is at a fixed frequency and since the lead connections are short.

Amplifier Design

The design and construction of tuned amplifiers for v-t voltmeter use is more difficult than the design of ordinary receiver amplifiers, although basically the two amplifier types are very similar. The greater difficulty is primarily due to the need for greater stability and per-

manence of both the gain and frequency calibration. At the same time, the desirability of a uniform frequency response adds to the design problem. The question of uniform frequency response does not arise in tuned amplifiers which work at a fixed frequency or do not require continuous tuning over a wide range. In tuned amplifiers providing continuous coverage, however, the design should be such that the variation in gain with frequency is held to a reasonable value.

In tuned amplifiers for v-t voltmeter use, improved performance can be obtained by considering such factors as adequate shielding, individual filtering of the leads to the various tube elements, the use of self bias rather than fixed bias, the use of degeneration, and above all by using very high-quality components which tend to be unaffected by age, temperature, humidity, mechanical shock, etc. When these precautions are taken it is possible to obtain performance characteristics which add greatly to the usefulness of the tuned v-t voltmeter.

Even where extreme precautions are taken in the design of tuned v-t voltmeters, including all the preceding details mentioned as well as a voltage-regulated power supply, it is not feasible to provide the tuned v-t voltmeter with a direct voltage calibration as in the case of the other v-t voltmeters described in this book. The reason is that there will always be residual variations which will affect the accuracy of the voltage calibration. This, however, does not seriously impair the usefulness of the tuned v-t voltmeter since it can always be accurately calibrated by means of a signal generator whenever calibration is required. Regardless of whether an absolute calibration is provided in this manner, the tuned v-t voltmeter can always be used for making relative measurements of signals with good accuracy. This latter feature is particularly important in signal tracing where the measurement of the relative signal levels at the grid and plate of a tube determine the performance of the stage.

Use As a Comparison V-T Voltmeter

The tuned v-t voltmeter can readily be used for the measurement of relative signal levels without the need for a meter and without an absolute calibration in microvolts. For example, with the basic tuned v-t voltmeter shown in Fig. 6-3, these measurements can be accomplished by means of the *multiplier*, *level control*, and an electron-ray or tuning-eye *indicator tube*. In this application the multiplier indicates changes in signal level in steps of 10 to 1, while the level control may be calibrated continuously over a range of 10 to 1 so as to provide complete coverage. The function of the electron-ray indicator in this setup will be clear from the following description of the manner in which a measurement is made.

To check the gain or change in signal level between two points,

for example between the control grids of two successive stages, the multiplier and level controls are adjusted so that the shadow on the electron indicator just closes. The probe is then shifted and the controls readjusted so that the shadow closes. It follows that the ratio of the two signal levels is equal to the ratio of the two attenuator settings. Note that the accuracy of the gain measurement does not depend upon the accuracy of the electron-ray indicator tube, since this serves only to establish a reference point.

Where an absolute calibration is required it can be obtained by connecting a signal generator to the tuned v-t voltmeter input. Once the sensitivity of the voltmeter is determined for one setting of the attenuation controls, the signal input for any other setting can be determined by using the indicated multiplying factor. Where the maximum accuracy is required, however, the equivalent signal input for any setting of the attenuation controls can be determined by using a calibrated signal generator. In this way the signal required to produce the same output with the same setting of the attenuation controls can be determined. For ordinary signal tracing, where this degree of accuracy is not required, it is sufficient to rely on the calibration of the multiplier and level controls.

A-F Output Connection

For signal-tracing work, it is desirable to provide the tuned v-t voltmeter with a connection to the rectifier circuit so that the waveform of the demodulated voltage can be observed. The design of the rectifier circuit is thus similar to the design of the detector circuit in a receiver, due attention being given to the capacity of the rectifier bypass condenser so that the higher audio frequencies are not attenuated. Such an output connection is useful for checking distortion and listening to the signal so as to check the presence of noise, hum, etc.

An oscillograph may be connected across the detector output where a visual examination of the waveform is required. In this application the amplifier in the tuned v-t voltmeter greatly increases the usefulness of the oscillograph by providing radio-frequency amplification to permit its operation. Since the conventional internal oscillograph amplifier functions only up to about 100 kilocycles, the oscillograph cannot be connected to the circuit through the internal amplifier. Where the tuned amplifier is used in conjunction with an oscillograph, the input capacitance is reduced from about 40 mmf to 1 mmf, the latter value being the input capacitance of the probe.

Chapter VII

AUDIO-FREQUENCY AND LOGARITHMIC VACUUM-TUBE VOLTMETERS

THE measurement of audio-frequency voltages usually calls for a special v-t voltmeter which we have classified in this chapter under the heading of *audio-frequency* and *logarithmic* v-t voltmeters. From the viewpoint of frequency range and input resistance, the v-t voltmeters described in the preceding chapters are entirely adequate for the audio-frequency range and in fact are widely used for audio-frequency as well as radio-frequency measurements. From the viewpoint of sensitivity, however, these v-t voltmeters leave much to be desired. For example, non-amplifier v-t voltmeters usually have a full-scale sensitivity of approximately 1 volt so that voltages less than 0.1 volt cannot be measured. Since many audio-frequency measurements are concerned with voltages of the order of millivolts, the inadequacy of the non-amplifier v-t voltmeter for such measurements is clearly apparent.

As we have seen in the preceding chapters, the conventional v-t voltmeter is relatively insensitive because it is not possible to use any amplification preceding the rectifier, in order to obtain a uniform frequency response extending up to high radio frequencies. In special purpose v-t voltmeters for audio-frequency work, however, this limitation is not present, because the frequency range does not exceed 15,000 cycles; usually a flat response to 10,000 cycles is adequate. This limited frequency range enables the use of a resistance-coupled amplifier by means of which a considerable increase in sensitivity can be obtained. Depending upon the number of resistance-coupled stages used, it is possible to obtain full-scale deflections for input voltages considerably lower than 100 microvolts. A number of typical audio v-t voltmeters employing resistance-coupled amplifiers will be described in this chapter.

The need for greater sensitivity is not the only requirement which has led to special v-t voltmeters designed exclusively for audio-frequency measurements. Low distortion, which is not a factor in other v-t voltmeters, is often an important factor in audio-frequency v-t voltmeters. Frequently provision is made so that the stable amplifier which is the

major part of an audio-frequency v-t voltmeter can be used as an amplifier for different applications apart from its use in the v-t voltmeter. Other requirements which are of importance in special a-f v-t voltmeters are the provision for a logarithmic scale so that a wide range of voltages can be read on the same scale without switching ranges. In applications where audio-frequency v-t voltmeters are used as volume indicators for monitoring transmissions and recordings, etc., the speed of response (damping) of the meter is of importance. The above illustrations are sufficient to show that audio-frequency v-t voltmeters present problems which are different from those encountered in general purpose v-t voltmeters.

A Simple Audio-Frequency V-T Voltmeter

The circuit of a useful audio-frequency v-t voltmeter of simple and inexpensive design is shown in Fig. 7-1. This instrument utilizes a high-gain resistance-coupled stage employing a type 6SQ7 tube. One of the diode sections of this tube is used to rectify the output voltage, the rectified voltage being applied through an R-C filter to the control grid of a 6E5 electron-ray tube which is used as the output indicator. An attenuator and level control in the input circuit are calibrated in terms of the audio voltage required to close the shadow of the 6E5 tube. The range covered is from 0.1 volt to 100 volts. The response is essentially uniform over the frequency range from 20 cycles to 10,000 cycles.

The attenuator, which is located in the input circuit, consists of a multiplier controlled by the switch *S1* and the calibrated potentiometer *R4*. By means of the multiplier switch the input voltage can be attenuated in steps of 10 over a range from 1 to 1000. The potentiometer *R4* permits a continuous coverage over a range of 1 to 10 on any one of the ranges selected by *S1*. In this way continuous coverage over a range from 1 to 10,000 is obtained. The signal voltages corresponding to the two extreme settings of the controls are 0.1 volt and 100 volts. To measure any voltage between these two ranges it is only necessary to note the position of the attenuator for which the shadow of the 6E5 just closes.

Provision is made in the output of the rectifier circuit so that the rectified voltage can be measured by means of an electronic or d-c v-t voltmeter (see Chapter VIII). Where this voltage is measured by means of a voltmeter connected to the jack *J2*, the lower limit of 0.1 volt can be extended to about 0.02 volt, since the d-c v-t voltmeter is capable of reading voltages smaller than the voltage required to close the shadow of the 6E5.

The potentiometer *R4* which is calibrated over a range from 1 to 10 should have an "audio" taper. In practice it is not possible to obtain

current so that the loading effect on the positive peaks (where the diode draws current) is negligible.

It is desirable to provide the 1 to 10 level control R_4 with a direct-reading scale so that the instrument will be direct reading in terms of the voltage required to close the shadow of the 6E5. This calibration can be accomplished by feeding voltages ranging from 1 volt to 10 volts into the input circuit, with the multiplier set at $X10$. By successively setting the control R_4 so as to close the shadow with 2 volts input, then with 3 volts input, etc., the necessary calibration marks can be obtained. Before this calibration is made, R_5 should be adjusted so that a 1 to 10 range is covered as previously explained. If the range is greater than 1 to 10, then R_5 is too small; if the range is less than 1 to 10, then R_5 is too large.

The use of the 6E5 electron-indicator tube contributes considerably to the simplicity, ease of operation, and low cost of this a-f v-t voltmeter. Since the only effect of an overload is to cause the shadow of the 6E5 tube to overlap, it is impossible to damage the instrument. This is an important advantage in a-f work, where the wide range of voltage encountered and stray pick-up cause frequent overloading.

Although no meters are used, the accuracy is adequate for all servicing needs and for many design purposes. This is especially true when the instrument is properly calibrated by adjustment of the target voltage and by use of the proper value of R_5 . Where greater accuracy is required, the instrument can always be calibrated at 60 cycles against the ordinary low-impedance copper-oxide rectifier or iron-vane type of a-c meter, as explained in Chapter IX.

The power supply used for this v-t voltmeter should preferably have some provision for adjusting the target voltage of the 6E5 so that the shadow will just close when a 0.1-volt signal is applied to the input. A suitable arrangement is shown in the figure where a 10-watt, 10,000-ohm resistor with a sliding adjustable contact is used to supply the target voltage. A conventional power supply can be used to supply the required 250 volts and the heater voltage for the 6E5 and 6SQ7. A bias cell is used to provide the necessary bias so that one of the diode sections of the 6SQ7 can be used as the rectifier.

It is convenient to use a shielded cable and probe in the input circuit so as to simplify connecting to the circuit under test. Several feet of low-capacity shielded cable fitted with a probe can be used without raising the input capacitance to a point where it is excessive for the usual run of audio-frequency measurements. For special applications, where the lowest possible input capacitance is desired, the triode type of amplifier tube should be replaced with a pentode, since the pentode stage of amplification has a lower input capacitance. This lower input capacitance of the pentode amplifier is due to the action of the screen which prevents reflection of capacitance to the input from the plate

circuit. Where a pentode amplifier is used, the operating conditions should be the same as for any resistance-coupled pentode stage. A suitable tube type is the 6J7 or its equivalent.

A High-Sensitivity Audio-Frequency V-T Voltmeter

For some audio-frequency measurements, it is necessary to deal with voltages which are considerably smaller than 0.1 volt. A sensitive audio-frequency v-t voltmeter suitable for the measurement of microphone levels and for the measurement of signal voltages in the first stages of high-gain amplifiers is shown in Fig. 7-2. This instrument employs a stable three-stage resistance-coupled amplifier which requires

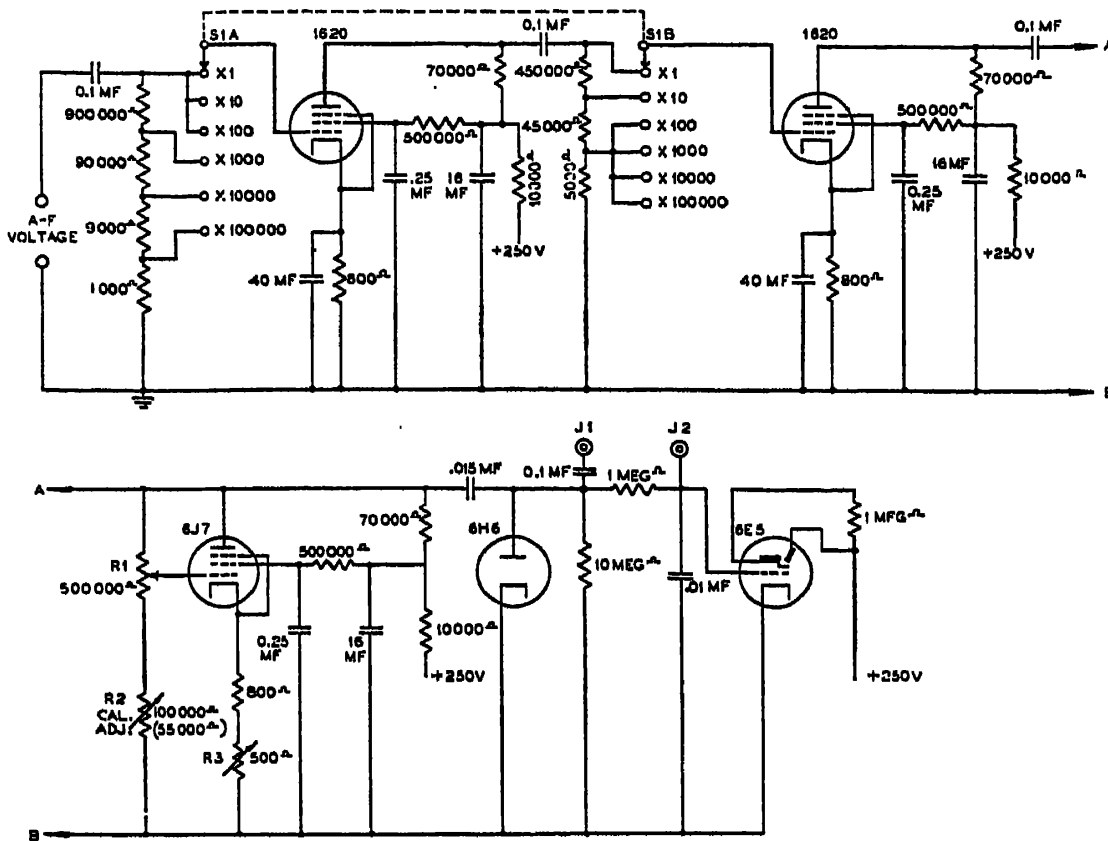

Fig. 7-2. A high sensitivity a-f v-t voltmeter using three stages of resistance-coupled amplification. An input signal of 100 microvolts is sufficient to close the shadow of the 6E5 electron ray indicator.

only a 100-microvolt signal to close the 6E5 shadow. An attenuator is provided so that stage-gain measurements can be made and so that voltages up to 100 volts can be measured. If desired, this attenuator may also be calibrated in decibels. The use of the 6E5 reference-level indicator in the output circuit has the advantage that overload will not cause any damage. This is particularly important in a high-gain

amplifier where even a slight amount of stray pickup or accidental contact will cause a heavy overload. Although a meter indicator is not used, quantitative voltage measurements can readily be made by means of the attenuator switch *S1* which gives voltage ratios of 10, and the input potentiometer which is continuously calibrated to cover the range from 1 to 10. With the potentiometer set at 1, and the multiplier switch at 1, the input signal required to close the 6E5 shadow is 100 microvolts. Any other input voltage can be determined by noting the setting of the two input controls. For example, if the multiplier switch setting is *X100* and the level control setting is 2.6, then the input voltage is $100 \times 2.6 \times 100$ microvolts, or 0.026 volt. In the same way, any other voltage can be measured by merely setting the attenuator controls so as to close the shadow of the 6E5.

The frequency range is essentially flat over the range from 20 cycles to 10,000 cycles. At 20 cycles the output is down less than 15%, while at 10,000 cycles the output is down less than 10%. In terms of decibels, the output is flat within less than 1.2 db over the frequency range from 20 cycles to 10,000 cycles. This frequency range is secured by using relatively small values of load resistance in the several stages so as to prevent a reduction in the high-frequency response. At the same time the low-frequency response is kept up by using large coupling condensers and grid resistors. Filtering of the plate and screen circuits of each stage, as well as separate self-biasing of each stage, contributes considerably to the overall stability of the amplifier.

The step attenuation is secured by means of a two-section switch in the input circuit to the first and second stages of the amplifier. Only on the most sensitive range (100 microvolts to close the shadow) is the maximum gain of the amplifier utilized. On the less sensitive ranges, the switch sections in the input circuit of the first and second tubes reduce the signal which reaches the output indicator. In this manner an attenuation of 100,000 to 1 is secured by means of the six-position switch *S1*.

The range of 1 to 10 is covered by means of the 500,000-ohm calibrated potentiometer *R1* in the input circuit to the final amplifier stage. The 100,000-ohm control *R2* in series with *R1* makes it possible to compensate for variations in the resistance of *R1* due to commercial tolerances. The range of 1 to 10 will be covered when *R2* is adjusted to about 55,000 ohms; more accurately its value should be $1/9$ the resistance of *R1*. The potentiometer *R1* may be calibrated by the procedure described on page 90 in connection with the v-t voltmeter shown in Fig. 7-1.

Because of variations in tube characteristics and resistors, the overall sensitivity of the amplifier will vary somewhat from the 100-microvolt value to close the shadow of the 6E5 indicator tube. To compensate for these initial variations, a variable control *R3* is provided in the cathode

circuit of the last a-f stage. To adjust this control the attenuator switches should be set in the position for which a 1-volt signal would normally close the shadow. With the known 1-volt signal applied to the input (multiplier switch in the $X1000$ position and $R1$ in the 1 position), it will be found that the shadow will either overlap slightly or else will not quite close completely. The proper adjustment of the sensitivity control is secured by rotating $R3$ until the shadow just closes. When this adjustment is made, the sensitivity of the amplifier will be exactly 100 microvolts to close the shadow and any value of signal up to 100 volts can be determined by noting the setting of the multiplier switch and potentiometer as previously explained.

Provision is made in the output circuit for connecting phones or an oscillograph by means of the jack $J1$. By means of a second jack $J2$, a d-c v-t voltmeter can be connected so as to measure the d-c voltage developed by the rectifier. Although this meter connection is not required ordinarily, it is useful in special applications. For example, by means of this jack it is possible to measure voltages smaller than 100 microvolts by noting the rectified voltage at the 6E5 grid.

A Television Amplifier V-T Voltmeter

A very useful v-t voltmeter can be made by adding a diode rectifier and d-c v-t voltmeter to a broad-band amplifier similar to those which are used in the vertical amplifier channels of oscillographs designed for television applications. This type of amplifier is also similar to the video amplifier of a television receiver. Since such amplifiers can be designed to cover a frequency range from several cycles up to about 3 or 4 megacycles, the addition of a rectifier to such an amplifier makes a sensitive amplifier type of v-t voltmeter which is capable of covering the same frequency range. Because the number of stages required for a given gain increases rapidly as the upper frequency limit is increased, it is not practicable to extend the frequency limit beyond about 500 kc for all except very special applications.

To illustrate this type of v-t voltmeter, we show in Fig. 7-3 the schematic of the vertical deflection amplifier used in the RCA Type 158 Television Oscillograph. This amplifier is designed to be used for making measurements on television receivers, particularly in the video, deflection, and synchronizing circuits of such receivers. As used in the oscillograph, a deflection sensitivity of about 0.4 volt-per-inch is provided, this value being obtained when a special shielded cable and probe having an input capacitance of only 8 mmf is used. When the input connection is made directly to the amplifier grid, the deflection sensitivity is approximately ten times as great or about 0.04 volt-per-inch. The input capacitance for this connection, however, is about 50 mmf so that the increased gain is offset by the higher input capacitance.

The rectifier circuit which has been added to this amplifier is shown in heavy outline. The addition of this rectifier circuit, in combination with a d-c v-t voltmeter to measure the rectified voltage, extends the usefulness of the amplifier by making it possible to measure smaller voltages than can be measured by observing the height of the wave on the oscillograph screen. Even for larger voltages its indication is more easily read so that the need for measuring the height of the pattern is eliminated.

The amplifier shown in Fig. 7-3 appears rather complex because of the care which has been taken to obtain a uniform frequency response and a minimum amount of phase distortion. This is accomplished by using unusually low values of load impedance and by incorporating high-frequency and low-frequency compensating circuits to keep the gain constant and reduce the phase distortion. The amplifier shown in Fig. 7-3 has a frequency response which is essentially constant over the range from 5 cycles to 500,000 cycles (500 kc). Over this range the phase shift is negligible, although this is of greater concern when the instrument is used as an oscillograph amplifier than when it is used as a v-t voltmeter amplifier. Since the rectifier circuit responds to the peak value, the v-t voltmeter is also of the peak type.

The relative complexity of the input circuit is due to the problem of obtaining uniform response and attenuation over the wide frequency range covered. To reduce the input capacitance of the amplifier, a special low-capacitance shielded probe is used. This probe contains an isolating condenser and resistor which blocks off the capacitance of the cable and of the amplifier input circuit, so that the effective input capacitance is only about 8 mmf. However, this reduction in the input capacitance is not accomplished without a corresponding reduction in the sensitivity. Thus the capacitance of the cable and input circuit is about 50 mmf, so that a loss of about 10 results from the use of the 5.6 mmf isolating condenser at the end of the shielded cable. To obtain the same voltage division at low frequencies, the 5.6-mmf input condenser is shunted by a 1-megohm resistor and the grid-ground circuit is likewise shunted by a resistor.

The attenuator consists of a double-pole switch which selects any one of four different attenuation ratios. Each of the attenuation factors is secured by tapping across a compensated voltage divider in which both a resistance and capacitance balance is present. Because both the resistance and capacitance ratio of each of the two elements is the same, uniform attenuation is secured over the entire frequency range. To compensate for variations in the capacitance of the components and for variations in stray capacitance, a trimmer condenser is incorporated in shunt with the lower section of the voltage divider so that the capacitance ratio between the upper and lower sections of the voltage divider is the same as the resistance ratio between the upper and lower sections

of the voltage divider. Four positions of attenuation are shown, the respective attenuation factors being 1, 5, 25, and 100.

The gain of the amplifier itself is approximately 450. Since there is a loss of about 10 in the input circuit because of the isolating condenser and resistor, it follows that the effective amplification is about 45. The rectifier produces approximately the peak voltage of the signal, so that a 1-volt input signal will produce about 45×1.41 or about 63 d-c volts of rectified voltage at the output of the diode rectifier. An input signal of 0.01 volt rms will produce approximately 1/100 of this d-c voltage or about 0.6 volt. Actually the d-c voltage will be less than this, since the efficiency of the diode rectifier is somewhat lower for values of a-c voltage less than 1 volt.

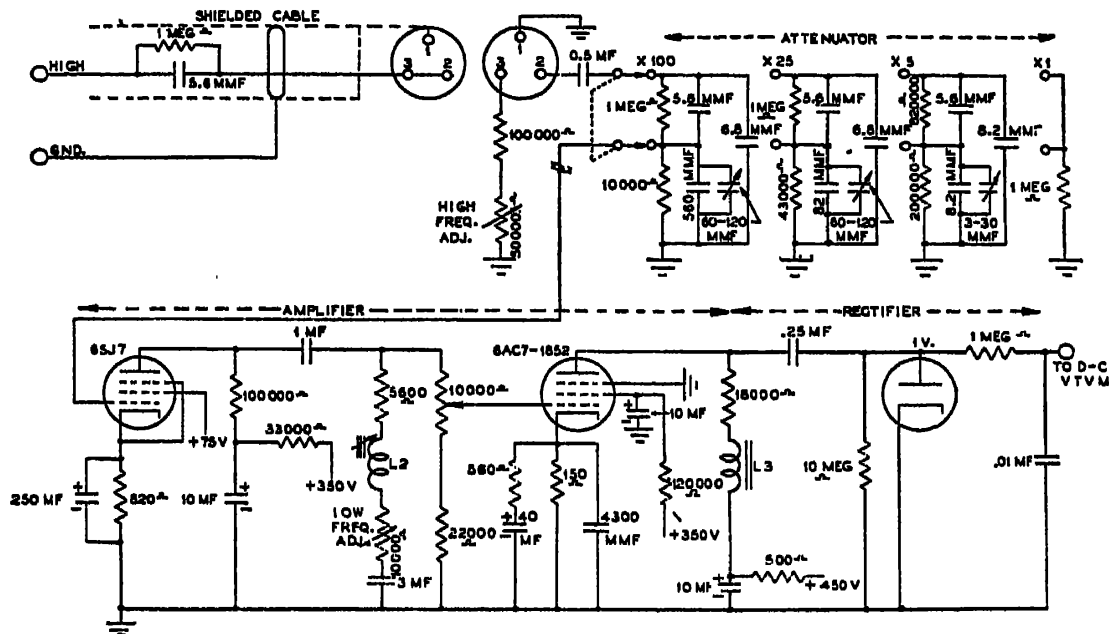

Fig. 7-3. A diode rectifier and d-c v-t voltmeter has been added to the vertical deflection amplifier used in the RCA Type 158 oscillograph, to enable its use as a sensitive a-c v-t voltmeter.

The increased sensitivity which results from the addition of the rectifier circuit is at once apparent. Whereas an input signal of 0.01 volt will produce a deflection of less than 1/32 inch, the rectifier arrangement will give a reading of approximately 0.5 volt. The latter value is easily readable on a d-c v-t voltmeter whereas the corresponding deflection on the screen of the cathode-ray tube is about the same as the width of the trace and hence not measurable.

Where a cathode-ray oscillograph having an internal wide-band amplifier is available, the usefulness of the instrument can be extended by the addition of a rectifier tube and filter, as shown in heavy outline in Fig. 7-3. Usually there is ample space inside the oscillograph so that

a rectifier tube can be installed near the final amplifier tube. Because of the negligible loading effect of the diode rectifier (a load resistance of 10 megohms is used) the rectifier can be left permanently connected to the output circuit. A jack can be brought out to the front panel of the oscillograph so that a d-c v-t voltmeter can be connected to measure the rectified output voltage.

As far as the calibration is concerned, it is sufficient to calibrate the reading of the d-c v-t voltmeter in terms of the input voltage with the attenuator control set in the *X1* position and with the input potentiometer set for maximum gain. Once this calibration is made, the unknown voltage for any one of the other ranges can be determined by using the indicated multiplying factor. Where the greatest accuracy is desired, the instrument should be used as a comparison v-t voltmeter, and the unknown voltage determined by noting the value of 60-cycle voltage required to produce the same output. This procedure is explained in detail on page 153.

Logarithmic V-T Voltmeters

A number of special applications of v-t voltmeters require a *logarithmic* type of response which is different from the linear or square-law response characteristic of the v-t voltmeters previously described. The logarithmic v-t voltmeter is particularly useful because it enables readings to be taken with the same degree of accuracy at any point on the scale, and because with proper design it is possible to cover an extremely wide range on the same scale without switching.

Logarithmic v-t voltmeters are used for the most part in applications where a wide range of voltages must be covered. A typical example of such an application is in the measurement of the field intensities of radio signals where values from several microvolts to several volts may be encountered. In automatic recording set-ups where it is not possible to change the range as the signal fluctuates, a logarithmic type of response is particularly valuable. Another illustration of the application of logarithmic v-t voltmeters is in volume indicators where the voltage under measurement also varies over a wide range. In monitoring the modulation of a transmitter, for example, the volume indicator must be capable of showing when the audio voltage is so *strong* that it will cause overmodulation, and at the same time it must also be sensitive enough to indicate audio voltages which are so *weak* that the modulation will not override the noise background. In sound measurements of all types the logarithmic v-t voltmeter is especially useful because the instrument has the same type of response as the ear. Just as the response of the ear depends only on the *percentage* change in the sound level, so the response (change in deflection) of the logarithmic v-t voltmeter depends only on the *percentage* change in the input voltage.

Comparison of Linear and Logarithmic Scale

The difference between the ordinary linear and the logarithmic scale is illustrated in Fig. 7-4. At first glance the logarithmic type of scale at (b) may tend to appear inferior to the linear scale at (a) because the logarithmic scale is not uniform. This non-uniformity, however, has the advantage of spreading out the lower portion of the scale so that readings can be taken more accurately than with a linear type of scale. In this respect the logarithmic scale is the opposite of the square-law scale in which the lower portion of the scale is crowded as shown in Fig. 3-8.

The following explanation shows how the logarithmic scale makes possible the same percentage accuracy of reading over the entire scale. Referring to Fig. 7-4b let us suppose first that a 1-volt signal is being

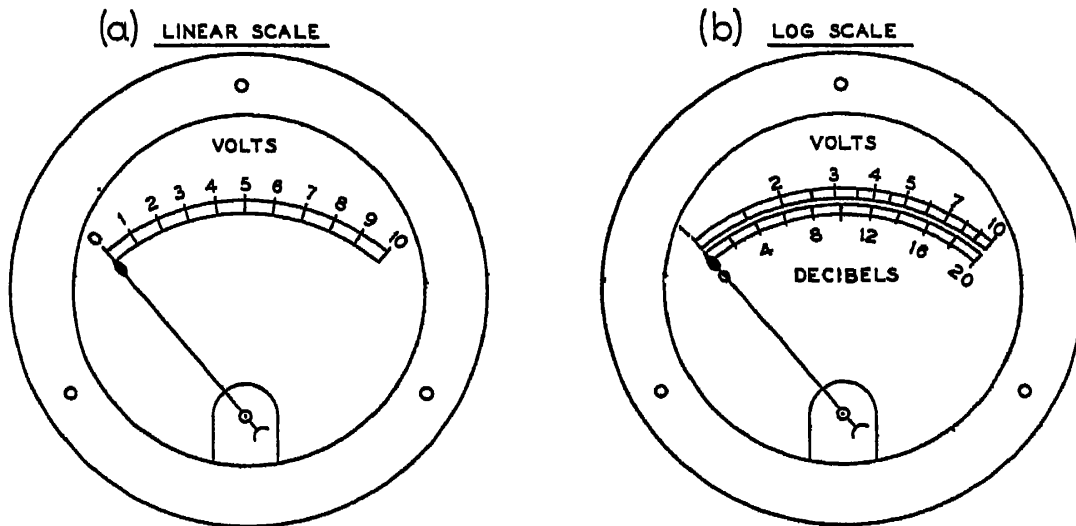

Fig. 7-4. A comparison of the linear and logarithmic scales shows that the logarithmic scale makes possible much greater accuracy of reading over the lower portion of the scale.

measured and that this voltage changes by 100% or by 1 volt; note the deflection which this change gives on the logarithmic scale at (b). Now suppose that a 5-volt signal is being measured and that this voltage changes by 100% or by 5 volts. Note that a change in voltage from 5 volts to 10 volts gives just as much of a change in the deflection as a change in voltage from 1 volt to 2 volts. In each case the change in input voltage is 100% and this 100% variation produces exactly the same change in the deflection.

By way of comparison, it is worth noting that on the linear scale at (a) the change from 1 volt to 2 volts gives only 1/5 of the change in deflection which is obtained for the same 100% change from 5 volts to 10 volts. Thus the accuracy of reading is considerably smaller at low

values on a linear scale. On a square-law scale, the accuracy of reading over the lower portion of the scale is even considerably poorer than for the linear scale.

A logarithmic scale such as is shown in Fig. 7-4b has many applications other than in v-t voltmeters. For example, logarithmic potentiometers are often used in Wheatstone bridges to obtain a logarithmic calibration so that the same accuracy of reading can be obtained for the small and large values of any range. Similarly, a logarithmic frequency scale is often used in audio oscillators so that low frequencies can be read with the same degree of accuracy as the higher frequencies. In general a great many phenomena in nature are characterized by a logarithmic response and so it is not surprising that logarithmic meters and scales should find a wide application for measuring these phenomena.

Linear Decibel Scale

If a logarithmic scale is calibrated in terms of decibels, a linear decibel calibration is obtained. Remembering that a decibel represents a fixed percentage change in the level (1 db represents a voltage change of about 12%), a logarithmic scale calibrated in terms of decibels or db will be linear because equal percentage changes occupy the same amount of space throughout the entire length of the scale. This is illustrated in Fig. 7-4b in which a logarithmic scale is shown calibrated in decibels, the decibel calibration appearing underneath the voltage calibration. Note that a change from 1 to 2 volts, a voltage ratio of 2, corresponds to 6 db above the 1-volt reference level. Similarly a change in voltage from 2 volts to 4 volts, from 3 volts to 6 volts, etc.,—all these voltage ratios of 2 to 1 (a 100% change) are represented on the decibel scale by an increase of 6 db.

Wide Range of Logarithmic Scale

In the previous section we indicated the manner in which a logarithmic scale makes possible the same degree of accuracy over the entire scale. In addition to this advantage, the logarithmic scale makes it possible to measure a wider range of voltages on a single scale without switching ranges. To illustrate this point we have shown in Fig. 7-5 a typical logarithmic scale which covers from 0.01 volt to 10 volts on the same range. Throughout this range of 1000 to 1 it is possible to read the scale with the same degree of accuracy. For example, a change in voltage from 0.01 volt to 0.02 volt produces exactly the same change in deflection as a change from 0.1 volt to 0.2 volt, or from 4 volts to 8 volts, etc. The great advantage of the logarithmic scale in providing a wider range can be realized at once by comparing this scale with a linear scale having the same full-scale value. Thus on a linear 10-volt

scale a deflection of 0.1 volt would give only 1/100 of full-scale deflection. With the logarithmic scale in Fig. 7-5, however, the same 0.1-volt signal gives a deflection of 1/3 of full scale!

Both the scales shown in Fig. 7-4b and in Fig. 7-5 are logarithmic scales. The scale in Fig. 7-4b, however, covers a range of 10 to 1, whereas the scale in Fig. 7-5 covers a range of 1000 to 1. It is possible to design logarithmic v-t voltmeters so that any given range can be covered. For

Fig. 7-5. A logarithmic scale covering a range of 1000 to 1. Over this entire range the same accuracy of reading can be obtained at every point.

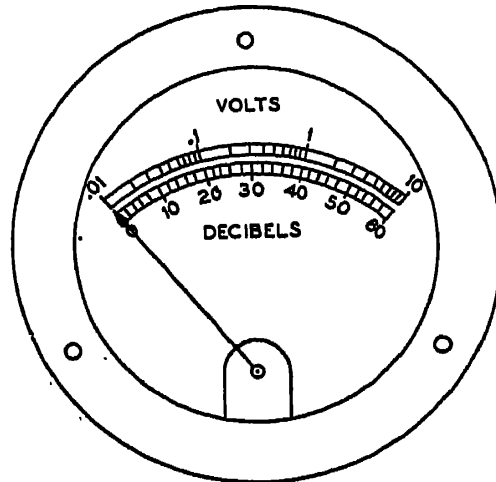

special purposes a ratio as wide as 100,000 to 1 can be covered in a single range. Usually, however, logarithmic v-t voltmeters have a useful range of about 10 to 1 (20 db) or about 20 to 1 (26 db). Of course the actual range of the v-t voltmeter can be made much larger than the scale range by using an attenuator or multiplier in the input to the v-t voltmeter. This practice is usually followed.

Types of Logarithmic V-T Voltmeters

Three basically different types of logarithmic v-t voltmeters are described in the following sections of this chapter. The first of these types depends for its logarithmic response upon the use of a special type of d-c milliammeter in which a non-uniform air gap is used. In the second type of logarithmic v-t voltmeter described, the logarithmic response is obtained by using an automatic-gain-control circuit similar to the automatic-volume-control (avc) circuit used in radio receivers. Because of the logarithmic characteristic of the variable- μ tubes used in the controlled amplifier, this circuit makes it possible to obtain a logarithmic response over a wide range of input voltages. The third type of logarithmic v-t voltmeter also depends upon the logarithmic characteristic of the variable- μ tube, but here the logarithmic response is secured by a special amplifier-rectifier circuit which will be described in detail.

Logarithmic Milliammeter

The conventional ammeter has a uniform air gap between the pole pieces (Fig. 7-6a) so that its response is directly proportional to the current through the moving coil. By using shaped pole pieces so that the air gap varies with the position of the moving coil (Fig. 7-6b), however, it is possible to make the deflection proportional to the logarithm of the current through the moving coil. When such a logarithmic milliammeter is used with an ordinary linear v-t voltmeter, it follows that the overall response of the v-t voltmeter becomes logarithmic.

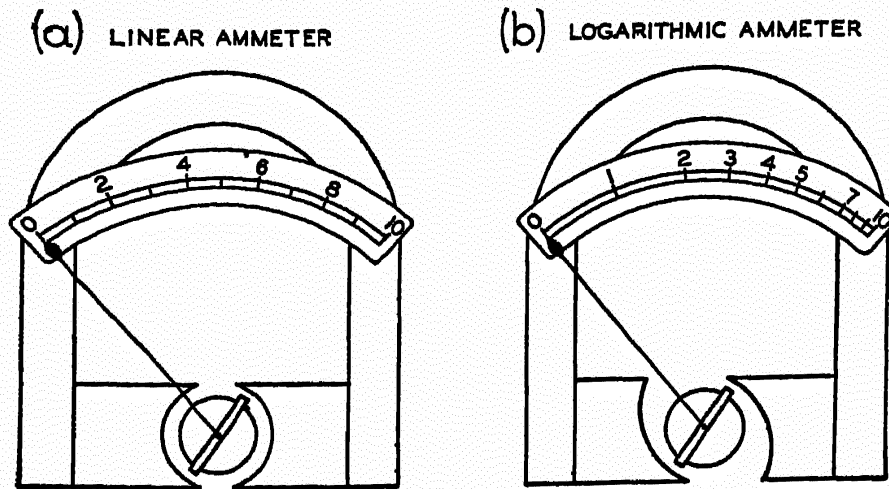

Fig. 7-6. The moving coil meter can be made to have a logarithmic response as shown at (b) by using shaped pole pieces so as to vary the width of the air gap continuously.

The action of the logarithmic milliammeter can be understood readily from the following description. When the current through the meter is small, the moving coil is in a relatively strong magnetic field because of the close spacing between the pole pieces. For this condition the sensitivity of the meter is relatively high. As the current through the meter increases, the coil rotates so that it is located in a weaker and weaker magnetic field and thus the sensitivity is progressively reduced. By properly shaping the pole pieces so that a logarithmic variation in the magnetic field is obtained, the scale deflection can be made to follow a logarithmic variation similar to that shown in Fig. 7-4b.

With the logarithmic type of meter the first 10% or so of the scale is usually not calibrated since a logarithmic or decibel scale begins with some fixed reference value of current or voltage. In some meters of this type, however, a "suppressed zero" type of construction is used. The term suppressed zero means that with no current through the meter the control springs are positioned so that the pointer presses against the left stop. Before the pointer will reach the first division on the scale,

an appreciable amount of current must flow through the moving coil. When a suppressed zero is used, the first division (which is normally zero) thus corresponds to a fixed value of current so that the entire scale can be utilized for the logarithmic calibration.

The logarithmic type of d-c milliammeter using shaped pole pieces requires a higher value of current for full-scale deflection than the conventional meter which has a uniform air gap. This reduced full-scale sensitivity is due to the sacrifice in sensitivity over the upper portion of the scale required in order to obtain a logarithmic response.¹

Because the scale of a logarithmic milliammeter is linear when a decibel calibration is used, such meters are very often called *decibel* meters. The meters, however, should not be confused with the conventional decibel meter which has a uniform air gap and a *non-linear* decibel scale.

Logarithmic V-T Voltmeter Using a Logarithmic Milliammeter

The logarithmic type of d-c milliammeter described in the preceding section can be used to simplify the construction of a logarithmic v-t voltmeter. As Fig. 7-7 shows, the circuit is generally similar to the audio

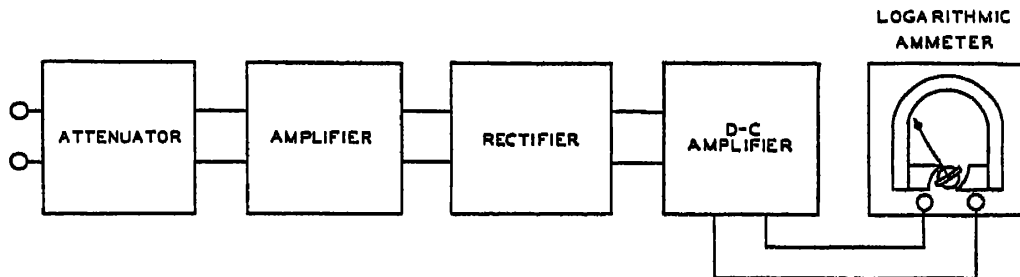

Fig. 7-7. Block diagram showing the structure of a logarithmic v-t voltmeter which employs the logarithmic type of milliammeter shown in Fig. 7-6b.

v-t voltmeters previously described, the essential difference being that the present circuit employs a logarithmic type of milliammeter. This substitution of the logarithmic milliammeter for the usual linear milliammeter makes the overall output logarithmic, although the other elements in the v-t voltmeter are linear.

Logarithmic milliammeters with shaped pole pieces are not usually stocked by meter manufacturers. As a general rule their use is limited to instrument manufacturers who can order a large enough quantity of meters of any one type to make it economical to manufacture a special

¹ For further information see Best, F. H., "Decibel Meters," Bell Lab. Record, Jan. 1937, p. 167.

meter. The logarithmic milliammeter is being used in the General Radio Type 759-A Sound Level Meter and in the Ballantine Model 300-A V-T Voltmeter. The former of these instruments uses a circuit basically similar to that shown in Fig. 7-7, while the latter instrument uses a degenerative amplifier in which the meter is located in a combination feedback-rectifier circuit.¹ Both of these instruments use an attenuator in the input circuit to extend the range covered on the logarithmic meter scale.

Controlled-Amplifier Logarithmic V-T Voltmeter

The logarithmic characteristic of variable-mu tubes (7S, 6K7, etc.) has been utilized in the design of logarithmic v-t voltmeters.² Fig. 7-8

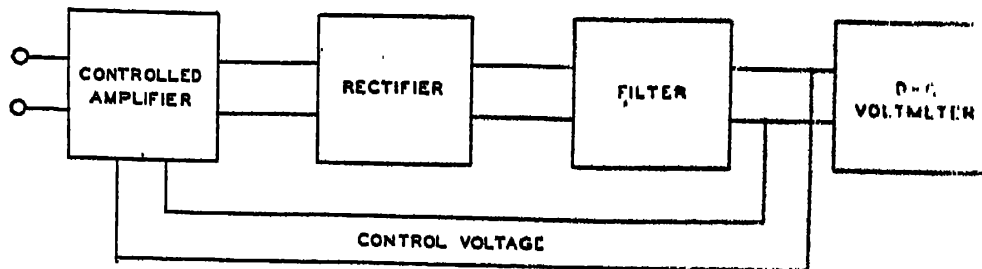

Fig. 7-8. A logarithmic response is obtained by controlling the gain of the variable-mu tubes in the amplifier section. The output is indicated by the d-c voltmeter used to measure the control voltage.

shows the basic circuit of this type of logarithmic v-t voltmeter in which the gain of the amplifier is controlled by a circuit similar to that used for obtaining automatic volume control in radio receivers. With this circuit, a voltmeter connected so as to measure the rectified control voltage gives a reading which is proportional to the logarithm of the input voltage.

The means by which this circuit produces a logarithmic response can readily be seen by comparing the action to that when no control circuit is used. With no control circuit, the voltmeter reading would be proportional to the input signal. When the control circuit is used, however, the gain of the amplifier is reduced progressively as the input signal is increased. This method of obtaining a reduction in sensitivity for higher input voltages may be compared with the logarithmic milliammeter method where the reduced sensitivity for large currents is obtained by increasing the air gap.

¹Ballantine, S. "Electronic Voltmeter Using Feedback," *Electronics*, Sept. 1938, p. 33.

²Ballantine, S. "Variable-Mu Tetrodes in Logarithmic Recording," *Electronics*, Jan. 1931, p. 472.

The above explanation merely shows qualitatively that the necessary compression of the scale for the higher values of input voltage is secured by an automatic-gain-control circuit. It does not follow from the above description that the scale distribution will be exactly logarithmic. A mathematical analysis, however, shows that when variable- μ tubes are employed in the amplifier, the rectified voltage will be closely proportional to the logarithm of the input voltage. The range covered depends upon the number of stages which are controlled, and increases very rapidly as the number of stages is increased.

Since the rectified voltage which provides the output indication is a high-impedance circuit, it is general practice to use a linear d-c v-t voltmeter to measure the control voltage and indicate the output. This usually consists of a single triode stage with a d-c milliammeter in the plate circuit. A typical arrangement will be shown in the following commercial circuit which is illustrative of the controlled-amplifier type of logarithmic v-t voltmeter.

An example of the controlled-amplifier logarithmic v-t voltmeter is shown schematically in Fig. 7-9. This is the circuit of the RCA Type 302-A logarithmic v-t voltmeter. This instrument is also designated as a noise meter since it was designed specifically for measuring noise levels. Basically the instrument consists of (1) a calibrated attenuator in the input circuit, (2) two stages of resistance-coupled amplification employing variable- μ tubes, (3) a diode rectifier, and (4) a d-c amplifier. The rectified voltage produced across the diode load resistor R_{10} is filtered and applied to control the gain of the two amplifier stages. At the same time this control voltage is applied to the grid of the 6R7 so as to vary its plate current. The logarithmic output indication appears on the scale of a 5-milliamper meter in the plate circuit of the 6R7. Provision is made in the output circuit so that a recorder can be operated for recording signal or noise levels.

Since the plate current of the triode is greatest when no signal is applied to the input, the meter used is of the type in which the pointer is normally at the extreme right of the scale. With no signal applied to the input, the plate current is a maximum since there is no negative control voltage produced by the rectifier. Thus the weakest input voltage is indicated by the pointer swinging toward the extreme *left* of the scale. As the input signal is increased, the rectified voltage increases so that the pointer deflects up the scale toward the right. As shown in Fig. 7-10, the scale is calibrated over a range of 40 decibels, from -20 db to $+20$ db. The zero reference level is taken as 1 milliwatt into 600 ohms, which corresponds to 0.775 volt across a 600-ohm resistor. Any decibel reading on the scale can, of course, be interpreted in terms of the input voltage by means of a standard decibel—voltage ratio conversion table.

By means of the attenuator in the input circuit a total range of 85

decibels can be covered. Of this range, 40 db is covered by means of the calibrated meter scale, while an additional range of 45 db is covered by means of the input attenuator which is calibrated in steps of 0.5 db. In terms of input voltage, this range of 85 db corresponds to a voltage range extending from 0.044 volt (-25 db) to 775 volts ($+60$ db). In addition to increasing the range, the attenuator makes it possible to check the calibration accuracy of the meter scale. The procedure for making this check is described in Chapter VIII.

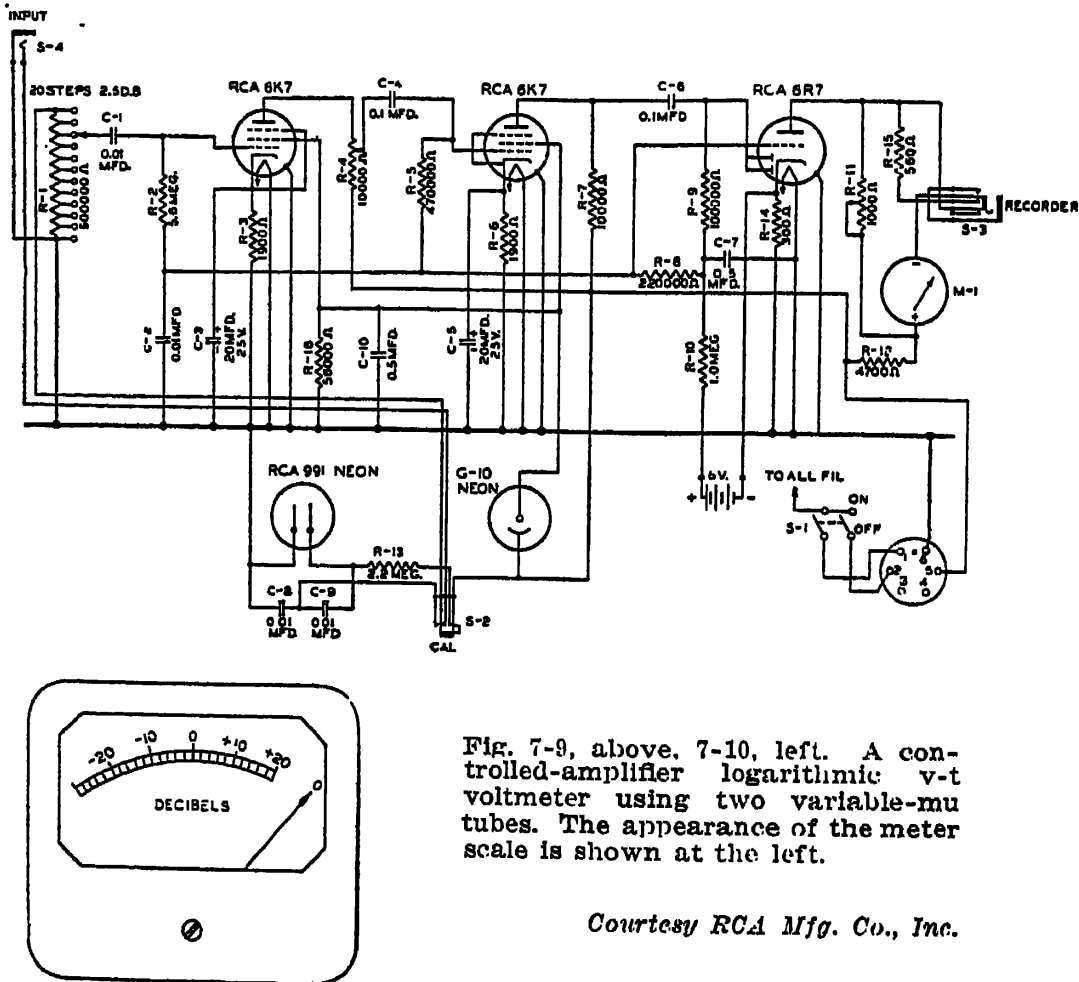

Fig. 7-9, above. 7-10, left. A controlled-amplifier logarithmic v-t voltmeter using two variable-mu tubes. The appearance of the meter scale is shown at the left.

Courtesy RCA Mfg. Co., Inc.

Two adjustments are provided which take care of variations in tube characteristics and circuit components. Referring to the schematic in Fig. 7-9, these are the adjustments R_4 and R_{11} . The potentiometer R_4 is used to control the gain so that 0.044 volt will read 0 db on the meter scale. The adjustable resistor R_{11} in shunt with the meter is used either to expand or contract the scale so that the meter calibration will be accurate. There is some interaction between these adjustments so that if one requires to be changed appreciably, the other one will also have to be reset.

A simple neon-tube oscillator using a 991 tube is incorporated in the instrument so as to provide an input signal for checking the accuracy of the scale calibration against the calibrated input attenuator.

An Amplifier-Rectifier Type Logarithmic V-T Voltmeter

The v-t voltmeter circuit shown in Fig. 7-11a at first glance appears to be an ordinary linear amplifier-rectifier type of v-t voltmeter such as was discussed in connection with audio v-t voltmeters. Actually,

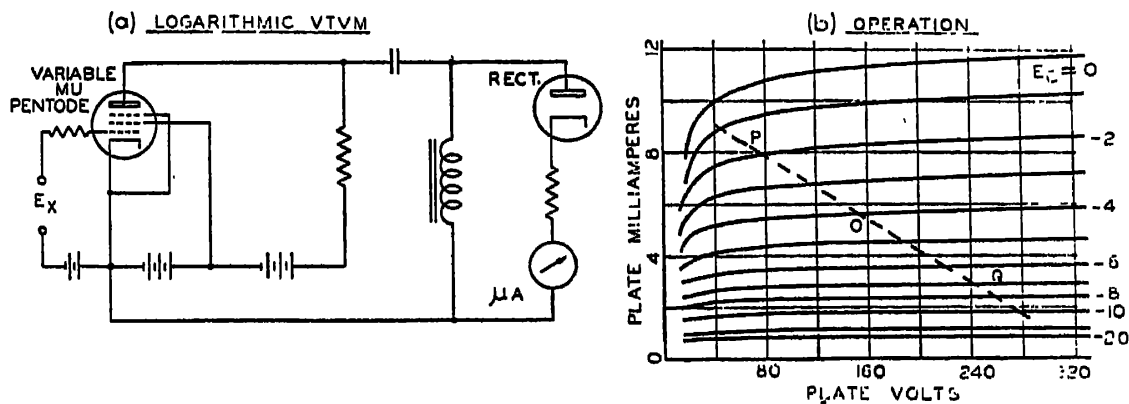

Fig. 7-11. The circuit and operation of a logarithmic type of v-t voltmeter.

however, this type of circuit can be designed to have a logarithmic response, provided that a variable-mu pentode tube is used with the proper operating conditions.¹

The operation of this circuit is as follows. When a signal is applied to the input, the grid of the tube is swung alternately positive and negative. On the positive half of the grid swing, the plate voltage decreases below the normal operating point *O* in Fig. 7-11b toward *P*. On the negative half of the grid swing, however, the plate voltage increases toward *Q* because the more negative bias decreases the plate current which in turn causes the plate voltage to rise. Line *POQ* is essentially a load line which shows how the plate voltage varies as the grid voltage is varied. The slope of this line depends upon the plate load resistance.

The positive grid swing can be ignored completely in the operation of this circuit, since the alternating voltage transferred to the diode as a result of the positive grid swing is negative and thus it will cause no rectified current to flow, and hence will not affect the reading of the microammeter. The negative grid swing, however, causes a positive

¹ Hunt, F. V., "A Vacuum-Tube Voltmeter with Logarithmic Response," Rev. Sci. Instruments, Dec. 1933, p. 672.

voltage to be applied to the shunt diode circuit and hence causes the diode to draw current through the microammeter.

The logarithmic response of the rectified current is a result of the compression which takes place because of the logarithmic characteristic of the variable- μ tube. In this connection note that the reduction in plate current (and increase in plate voltage) for each succeeding volt decrease in grid voltage becomes progressively smaller as the grid voltage decreases. For example, the decrease in plate current caused by a 10-volt change in grid voltage from 15 to 25 volts is even less than the change in plate current caused by a change of only 1 volt from 7 volts to 8 volts. The compression effect is even greater than appears in the figure because of the loading effect of the diode. Provided the operating conditions are suitably chosen, the response of a single stage such as is shown in Fig. 7-11a can be made logarithmic over a range from about 3 db to about 15 db, the reference level being 1 volt. This corresponds to a voltage range from approximately 1.4 volts to 6.0 volts. Since no filter circuits are used, the response of this circuit to changes in the input voltage is extremely rapid.

A logarithmic response over a wider range of input voltages can be obtained by using two or more stages similar to Fig. 7-11a; a two-stage circuit is shown in Fig. 7-12. The reason for the wider logarithmic response with two stages can be seen from the following explanation. When two stages are used, the signal is amplified in each stage so that diode D_2 , which rectifies the output of the second stage, will start to draw current first. The response of this diode will be logarithmic up to a certain point, beyond which it tends to saturate so that no further increase in current is obtained. Before saturation of diode D_2 is reached, however, the signal level at the output of the first stage is strong enough so that diode D_1 begins to rectify and carry on where the diode D_2 left off. The result is a considerable extension of the range over which a logarithmic response is obtained. Using type 39 tubes and the constants shown in the figure, a logarithmic response can be obtained over a range from about -30 db to $+20$ db, using 1 volt as the reference level. In terms of voltage, the response is logarithmic over the range from about 0.03 volt to 10 volts. Similar performance can be expected using variable- μ tubes of the 6K7, 1T4, etc. types.

By using three stages a still wider logarithmic range can be covered. With three tubes, a range of from -60 db (0.001 volt) to $+20$ db (10 volts) has been obtained by the originator of this circuit. Note that the increase in the number of stages broadens the logarithmic response in the direction of weaker signals, but does not increase the upper limit of the logarithmic range which is limited only by the response of the first stage.

The resistors in series with the several control grids are used to

prevent loading of the preceding circuit as the result of grid current. These resistors do not interfere with the operation of the circuit since

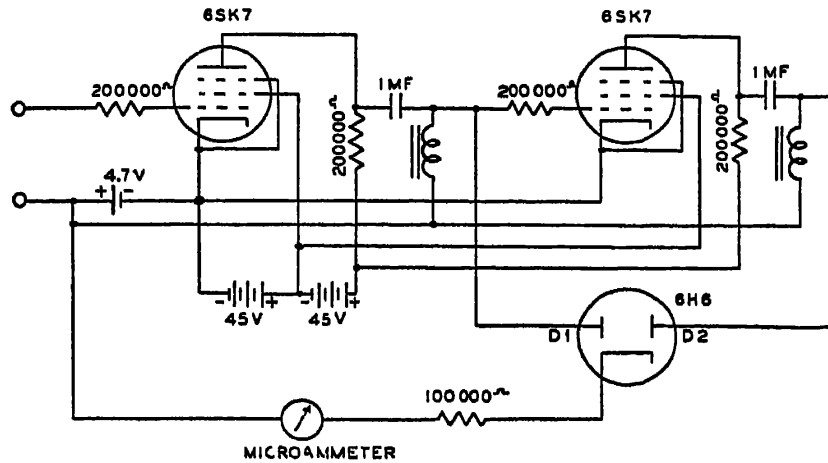

Fig. 7-12. A two stage logarithmic v-t voltmeter using the basic circuit shown in Fig. 7-11.

only the negative grid swing is effective in causing rectification to take place in the plate circuit. Excessive values of resistance should not be used, however, or the high-frequency response of the amplifier will be reduced.

Chapter VIII

VACUUM-TUBE VOLTMETERS FOR D-C VOLTAGE, CURRENT, AND RESISTANCE MEASUREMENTS

THE use of the v-t voltmeter for d-c voltage measurements was touched upon briefly in Chapter I. There it was shown that the basis of the d-c v-t voltmeter is the interpretation of the unknown voltage applied to the input terminals in terms of the resulting plate current which is measured by a d-c milliammeter or microammeter. Fig. 1-3 and the accompanying description may be referred to for a review of the elementary principles underlying the d-c v-t voltmeter. The simple v-t voltmeter shown in Fig. 1-3 is the basis for numerous refinements in design which make possible the measurement of d-c voltages, current, and resistance over an extremely wide range.

The advantage of the d-c v-t voltmeter over the conventional d-c voltmeter is primarily due to the much higher input resistance of the v-t voltmeter. In addition to the advantage of higher input resistance, considerably greater sensitivity can be obtained than with the conventional meter. This greater sensitivity results because the inherent sensitivity of the moving-coil meter is combined with the amplification made possible by the vacuum-tube circuit. An important consideration is the protection which the vacuum-tube circuit provides against damage to the indicating meter. In the measurement of very small d-c voltages and currents, it is possible to obtain greater speed of operation with the v-t voltmeter than with a galvanometer of comparable sensitivity. Because the amplification provided by the vacuum-tube circuit enables the use of relatively insensitive meters, the v-t voltmeter is more rugged and less expensive than the non-electronic meter. Provided that proper design is employed, it is possible to obtain accuracy and stability comparable to that of instruments which do not employ vacuum tubes.

In designing v-t voltmeters for d-c measurements it is undesirable to operate the amplifier tube at the rated conditions which yield the greatest mutual conductance (sensitivity), because such operation is accompanied by a lowering of the input resistance and the flow of a small but nevertheless appreciable value of grid current. In addition,

a considerable degree of non-linearity results when no degeneration is used. This tends to make a direct calibration impossible because of the dependence of the calibration upon the tube characteristic and the operating voltages. Additional factors which must be taken into account are the provision of a balancing circuit which will provide adequate stability of operation. Although the d-c v-t voltmeter is basically simple, it is clear from the above outline that a number of important factors must be considered in order to obtain a satisfactory d-c v-t voltmeter.

Input Resistance and Grid Current in D-C V-T Voltmeters

A basic factor in the design of v-t voltmeters is the choice of the tube and the operating conditions so that a high input resistance and low grid current will be obtained. The necessity for low grid current can be seen from the following considerations. If an appreciable value of grid current flows, then the potential at the grid will vary depending upon the resistance which happens to be present in the grid circuit. Thus the plate current will show a corresponding variation so that the voltage reading obtained will depend upon the internal resistance of the voltage source being measured. Such a condition is clearly undesirable. A properly designed d-c v-t voltmeter will give a reading which is independent of the resistance in the grid circuit up to values of at least several thousand megohms. Special d-c v-t voltmeters have been designed in which the resistance in the grid circuit may be higher than ten million million megohms!

In describing a d-c v-t voltmeter it is not sufficient to know that the input resistance is 10 megohms, 5000 megohms, or whatever the particular value may be. This is only a part of the story; in addition, it is necessary to know the *grid current*. For example, a v-t voltmeter may use a voltage divider which has a resistance of say 20 megohms, in which case its *input resistance* would be specified as 20 megohms. This alone, however, is not sufficient since there may be an appreciable grid current. For example, even if the grid current is as small as 0.01 microampere, this grid current will cause a voltage drop of 0.2 volt across the 20-megohm grid resistor. If the input leads of the instrument are shorted, it follows that there will be a shift of 0.2 volt in the reading of the instrument. Such an instrument would show an error of as much as 0.2 volt because of the flow of grid current.

For complete information on the input circuit of a d-c v-t voltmeter it is thus necessary to know not only the input resistance, but also the grid current. Of course, the grid current depends upon the voltage which is applied to the grid, but usually it is satisfactory to specify the grid current which flows when no external voltage is applied.

A satisfactory check for grid current can readily be made by short-

ing the test leads and noting whether there is any shift in the zero reading. This check should be made while the v-t voltmeter is on the most sensitive range. If the v-t voltmeter is of the type which does not use a voltage divider in the input circuit on the lowest range, then the test should be made with about 10 megohms in the input circuit. The change in the position of the zero will be negligibly small, provided the grid current is sufficiently small.

Accuracy of D-C V-T Voltmeters

With proper design the accuracy of a d-c v-t voltmeter can be made to approach the accuracy of the meter movement itself, surprising as this may seem in view of the comparatively large number of variables involved. Where sufficient degeneration is used, the calibration can be made to depend only upon the value of the resistors used, and can be made independent of variations in tube characteristics and line voltage. Production variations in the meter sensitivity and other circuit constants are usually taken care of by an internal calibration adjustment. The greatest single source of error in d-c v-t voltmeters is in the input voltage divider, where one is used. In order to obtain a high input resistance, high values of resistance must be used in the voltage divider. These resistors tend to show a greater variation in resistance with temperature and age than do low values of resistance. By carefully matching resistors in the voltage divider and by using resistors which have about the same temperature coefficient, this error can be reduced to a satisfactorily low value. Where the greatest accuracy is required, the v-t voltmeter can always be checked against an accurate low-resistance voltmeter.

The Slide-Back V-T Voltmeter for D-C Voltage Measurements

The application of the slide-back v-t voltmeter for the measurement of d-c voltages is described in detail on page 65. Unlike the other d-c v-t voltmeters to be described later in this chapter, the slide-back v-t voltmeter has the disadvantage that it is not direct reading, but requires a balancing adjustment in order to obtain a measurement. Other disadvantages of the slide-back v-t voltmeter for d-c voltage measurements are the necessity for an internal voltage supply which must be at least as large as the highest voltage to be measured. With reference to grid current, the slide-back v-t voltmeter is subject to the same possible source of error as the direct-reading d-c v-t voltmeter, so that care must be exercised in the choice of the tube types and in the operating conditions under which the slide-back triode functions. In general, low- μ triodes are more satisfactory than

high- μ triodes since they have a lower grid current and a smaller "contact potential."

A Simple Center-Zero D-C V-T Voltmeter

The d-c v-t voltmeter shown in Fig. 8-1 is similar in basic design to the fundamental d-c v-t voltmeter shown in Fig. 1-3. In the present circuit, however, the tube is biased in the middle of the grid voltage-

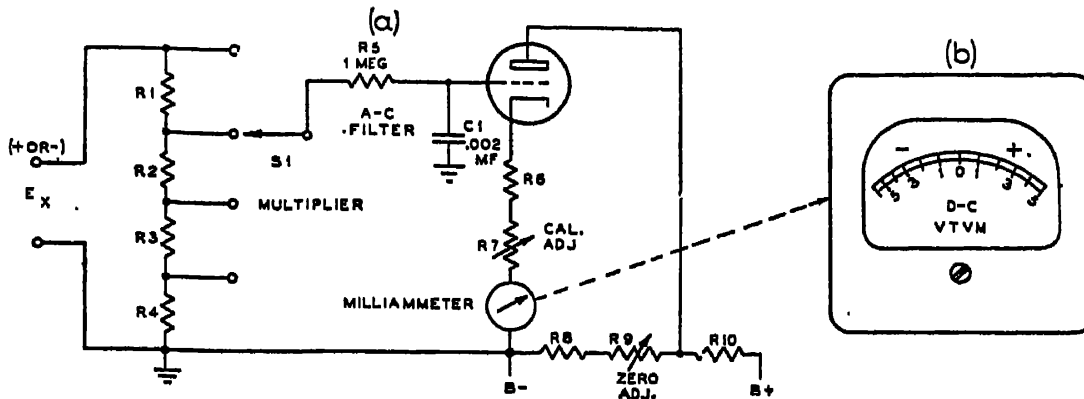

Fig. 8-1. Typical constants for 5, 25, 125, and 500 volt ranges using a 76 tube, an 0-1 ma meter, and a 200-volt plate supply: $R_1 = 8$ megohms; $R_2 = 1.6$ megohms; $R_3 = 300,000$ ohms; $R_4 = 100,000$ ohms; R_6 and $R_8 = 6000$ ohms; $R_7 = 2000$ ohms; $R_9 = 10,000$ ohms; $R_{10} = 27,000$ ohms.

plate current characteristic so that the milliammeter reads in the middle of the scale when no voltage is applied to the grid. This point on the scale is designated as zero. If a positive voltage is applied to the input terminals, the plate current of the tube will increase so that the meter will deflect up the scale from the center-zero position. If a negative voltage is applied, the plate current decreases so that the meter deflects down the scale to the left of the zero. A typical scale for this type of center-zero d-c v-t voltmeter is shown in Fig. 8-1b. Note that the milliammeter is calibrated directly in terms of the unknown d-c voltage which is applied to the input terminals. The slight compression of the lower portion of the scale is due to the non-linearity of the tube characteristic near cut-off.

To obtain increased stability and independence of tube characteristics, a self-bias arrangement is used to provide the operating bias. The cathode resistor provides sufficient degeneration so that satisfactory stability and independence of tube characteristics is secured. The *calibration adjustment* R_7 enables compensation to be made for variations in meter sensitivity, tube characteristics, circuit constants, etc. This adjustment is an internal one, which is made only when tubes are changed or when any of the resistors are replaced. The control R_{10} in the voltage divider circuit is used to vary the plate voltage so that the pointer will read zero or mid-scale when no voltage is applied

to the input terminals. Thus this control functions as a *zero adjustment*.

The *center-zero arrangement* used in this circuit has a number of advantages, particularly where it is desired to make a d-c v-t voltmeter of simple design and low cost. Thus this type of circuit eliminates the need for a *polarity switch* which is otherwise required in order to be able to measure both positive and negative voltages. At the same time the design is simplified considerably since perfect linearity is not required over the range of both positive and negative voltages, as is the case where the full scale is utilized. In service work, where it is necessary to switch rapidly from the measurement of positive to negative voltages, as for example in measuring first the negative grid voltage, then the positive plate voltage, etc., it is convenient to be able to change from positive to negative voltages without shifting a polarity switch.

Where the conventional *left-zero arrangement* is used in conjunction with a polarity switch, the disadvantage of having to manipulate the polarity switch is offset by the fact that the calibration is spread out over the full scale. Thus there are advantages in both the center-zero and left-zero circuits; which is preferable depends upon the particular requirements that the instrument is designed to meet. A number of circuits using the conventional left-zero arrangement will be described in this chapter.

An *a-c filter* is used in the center-zero circuit shown in Fig. 8-1. This filter, consisting of $R5$ and $C1$ in the grid circuit, is designed to remove any a-c component or signal voltage which may be present at the point where the d-c voltage is being measured. The values shown are sufficient to provide adequate attenuation for practically all applications. Excessively large values of either R or C should not be used since a large time constant will tend to make the action of the v-t voltmeter sluggish. The grid condenser $C1$ should be a mica condenser since low d-c leakage is essential if the accuracy of the voltmeter is not to be affected. It is worth noting that complete attenuation of any a-c component which may be present is not required since the linearity of the circuit permits a considerable grid swing to take place before rectification alters the reading of the milliammeter.

Four voltage ranges are provided by means of the voltage divider and selector switch $S1$ in the input circuit. To obtain satisfactory accuracy, these resistors should be accurate to 1%. In production, an improvement in the accuracy of the voltage divider can be effected by separating the voltage divider resistors at the time they are checked into two groups which are (1) between 0 and +1% and (2) between 0 and -1%. If all the resistors for any one instrument are selected from any one group of resistors, the accuracy of the voltage divider can be doubled.

Isolating Resistor—"Signal Circuit" Probe

The v-t voltmeter shown in Fig. 8-1 may be used in connection with the type of probe shown in Fig. 8-2. This probe has the advantage that the input capacitance of the voltmeter is reduced to about 1 mmf. This low input capacitance prevents detuning and loading of r-f circuits and so permits measurements to be made under dynamic operating conditions. For example, using this type of "signal-tracing" probe,

Fig. 8-2. The isolating resistor in the probe enables d-c voltages to be measured at points where r-f voltage is present without detuning the circuit.

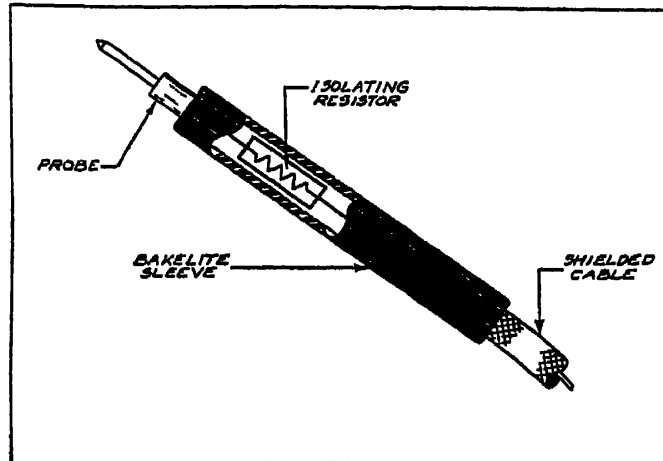

it is possible to make measurements directly at the control grid of an oscillator tube so as to check its operation by determining the rectified grid voltage. Similarly, it is possible to measure automatic-volume-control (avc) voltage directly at the control grids of tubes which are receiving avc voltage. In the above examples, the use of an ordinary probe without an isolating resistor would detune and load the r-f circuits so that the measurements could not be made.

The effect of an isolating resistor at the end of the voltmeter lead must of course be considered in the calibration of the v-t voltmeter. For example, if the input resistance of the v-t voltmeter is 10 megohms, a 1-megohm isolating resistor, which is the value usually employed, would reduce the deflection by about 10%. This reduction in sensitivity, however, can readily be taken into account in the initial calibration. The instrument will then be accurate when used with the isolating probe which can be considered an integral part of the instrument.

In d-c v-t voltmeters which are not provided with this type of probe, the same objective of preventing detuning of r-f circuits can be obtained by temporarily clipping a 1-megohm resistor to the end of the test lead, and using the other end of the 1-megohm resistor as the input or probe point. Where this arrangement is used, the v-t voltmeter will read less than the true voltage by an amount equal to the voltage drop across the 1-megohm isolating resistor. The error depends upon the input resistance of the v-t voltmeter and will be greater the smaller

the value of the input resistance. To obtain the correct voltage, the reading should be multiplied by $(1 + R_1/R_2)$ where R_1 = resistance of the isolating resistor and R_2 = input resistance of the v-t voltmeter.

Polarity Considerations in D-C V-T Voltmeters

Some attention has already been given to the question of *polarity* in d-c v-t voltmeters. In the center-zero v-t voltmeter just described, the measurement of both positive and negative voltages is taken care of by the center-zero arrangement. This permits the low input terminal to be connected to ground at all times, so that positive and negative voltages can be measured without switching leads. Another type of circuit, shown in Fig. 8-6, also permits positive and negative voltages to be measured. In this balanced circuit the *polarity of the milliammeter connection to the vacuum-tube circuit is reversed*, so that the input leads need not be interchanged in order to measure positive and negative voltages.

There are several reasons why the low input terminal should be connected to the ground or low side of the voltage being measured. If the leads are reversed, the effect will be to ground the grid circuit and to place the cathode circuit "up in the air." Because of the comparatively high input resistance of the v-t voltmeter, such a connection will cause leakages through the a-c line and between the instrument case and ground to affect the reading of the meter. In addition the resulting stray a-c pickup may overload the input circuit so that rectification will take place and also cause error. An additional reason for always keeping the low input terminal of the v-t voltmeter connected to the ground or low side of the circuit being measured involves the question of safety. Usually the low terminal is connected to the chassis and cabinet of the instrument. If this low terminal is connected to a point which is highly positive or negative with respect to ground, touching the instrument case and the low side of the circuit under test will result in a shock. For all of the above reasons it is recommended that the low v-t voltmeter terminal be connected to the low or ground side of the circuit being measured. Positive or negative voltages can then be taken care of by using a center-zero v-t voltmeter circuit or by using a balanced v-t voltmeter circuit in combination with an internal polarity switch.

Measuring Voltages Between Points Above Ground

In connection with the problem of keeping the low terminal of the d-c v-t voltmeter tied to the low side of the circuit under measurement, it is sometimes necessary to measure the voltage difference between two points which are several hundred volts above or below ground.

In such an instance, it is not recommended that the instrument be connected directly across the two points, since this procedure exposes the operator to the danger of shock as explained in the preceding section. A preferable method of making the measurement is to measure the voltage at each of the points with respect to ground. The desired differential voltage can then be determined by taking the difference between the two voltage readings.

Where the voltage difference is quite small, a considerable error will occur in the measurement because the measurement depends upon taking the difference between two large voltages. If high accuracy is required, it can be obtained by ignoring the general rule stated above, and connecting the instrument directly across the two points in question. The instrument can then be set to a low voltage range and the desired voltage readily measured. Extreme care should be taken, however, to see that the operator does not come in contact with any part of the instrument since the instrument case is not at ground potential. Immediately upon completion of the measurement, the low terminal of the v-t voltmeter should be removed from the high-voltage point so as to prevent possible shock.

In some v-t voltmeter designs, the low input terminal is not connected directly to the panel or chassis of the instrument, but is connected through a high resistance and condenser. An example of this design appears in Fig. 5-7. This isolating circuit has the advantage that it is possible to ground the instrument case even when the low input terminal is above or below ground potential. Even where this feature is provided, it is usually desirable to limit the voltage difference between the low and ground terminals to approximately 200 volts.

Obtaining a Center-Zero Deflection for Galvanometer Applications

In a number of applications involving the use of the d-c v-t voltmeter, it is desirable to have a center-zero indication. Typical applications of this type are the measurement of the discriminator output in automatic-frequency-control and frequency-modulation receivers, and the use of the d-c v-t voltmeter as a galvanometer in bridge applications. A *center-zero* d-c v-t voltmeter is directly applicable to these measurements because *plus* and *minus* variations from the balance condition are indicated on the same scale without any polarity switching. With the *left-zero* v-t voltmeter, on the other hand, the meter deflects off scale during the balancing procedure. By the addition of an external biasing circuit, however, it is possible to convert the left zero v-t voltmeter into a center-zero v-t voltmeter.

A simple method for obtaining a center-zero reading on a left-zero v-t voltmeter is shown in Fig. 8-3. The voltage of the biasing battery

in series with the high input lead should be at least half as large as the lowest full-scale range of the v-t voltmeter. By adjusting the potentiometer across this battery, while the input leads are shorted, the meter can be made to deflect to the center of the scale. When this adjustment is completed, the center of the scale becomes the new zero of the v-t voltmeter, so that positive and negative voltages will cause deflections on either side of the center, just as in the ordinary center-

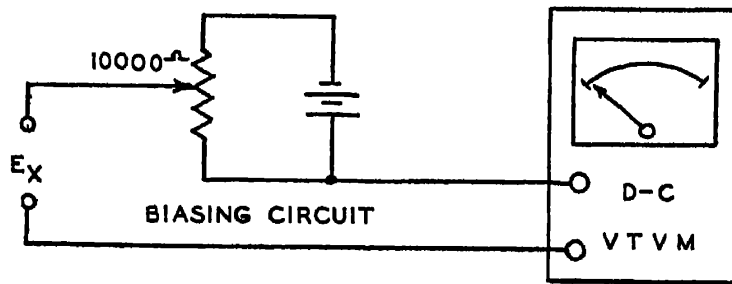

Fig. 8-3. By means of this circuit a conventional left zero v-t voltmeter can be converted into a center-zero meter.

zero meter. The meter can then be used for balancing adjustments of any type in exactly the same way that a galvanometer or other type of center-zero instrument would be used. The calibration is not affected by the addition of this external biasing adjustment provided that the voltages are reckoned from the center, with each division having the same voltage value as it had before the addition of the biasing circuit.

A Single-Tube Degenerative V-T Voltmeter

The need for a voltage divider in the input circuit of d-c v-t voltmeters can be eliminated, at least for voltages up to about 100 or 200 volts, by means of a range switch which controls the amount of degeneration. The basic amplifier circuit used in this type of d-c v-t voltmeter is shown in Fig. 8-4. When a large cathode resistor R is used in such a circuit, an analysis of the circuit shows that a voltage E_g applied to the grid will cause a voltage E_R to be developed at the cathode which is almost equal to the original voltage applied to the grid.

The operation of the circuit will be clear from the following description. When a positive voltage E_g is applied to the grid, the plate current increases so that a voltage drop takes place across the cathode resistor as a result of the increase in plate current. Because the polarity of this voltage drop E_R opposes an increase in plate current, the cathode resistor R exercises a controlling effect on the plate current. In no case can the plate current increase be greater than an amount which will cause the resulting voltage drop across the cathode resistor R to equal the unknown voltage E_g applied to the grid.

It can be shown that the expression for the change in plate current in the basic circuit of Fig. 8-4 is equal to

$$\text{Plate Current Change} = \frac{G_m E_a}{1 + RG_m} = \frac{G_m E_a}{G_m R} = \frac{E_a}{R} \quad \text{when } RG_m \text{ is}$$

large in comparison with 1. This expression shows that when R is sufficiently large, the change in plate current depends only on the value of the cathode resistor and is completely independent of the tube characteristic and operating voltages. In particular the change in plate current is then equal to the applied grid voltage E_a divided by the cathode resistance R .

Fig. 8-4. The fundamental circuit of a degenerative d-c amplifier such as is used in many d-c and rectifier-amplifier v-t voltmeters.

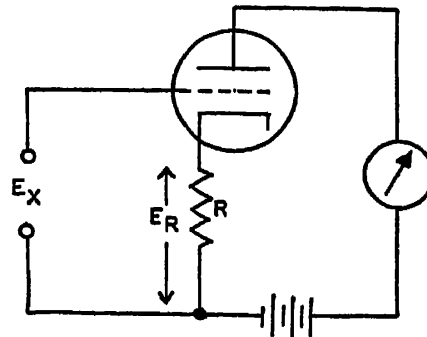

From the preceding description it is clear that the use of such a degenerative circuit makes it possible to apply much larger voltages than can ordinarily be applied to the grid circuit. This advantage is made possible by the degenerative voltage E_R produced across the cathode resistor; this voltage balances out the large applied grid voltage so that the net grid-cathode voltage change is small and within the normal range of grid voltages which the tube is capable of handling. The only limitation on the voltage which can be applied to the grid is that the plate voltage must always be somewhat higher than the highest voltage which is applied to the grid, in order that the tube may operate as a triode.

When the sensitivity of the amplifier is varied by changing the cathode resistance, it is necessary to change the bias voltage so that the tube will still operate over the linear portion of its characteristic. This is accomplished in Fig. 8-5 by means of a switch $S1B$ which is ganged with the switch $S1A$ selecting the cathode resistor. When the proper value of bias voltage is used for each range, it is possible to maintain the normal value of operating plate current on all ranges. If the simplified circuit shown in Fig. 8-4 were used, proper operation would not be obtained with large cathode resistors because the tube would be functioning near cut-off where the mutual conductance is very small, and the characteristic is non-linear.

The following example shows how the bias voltage can be varied to

maintain the plate current at the same value on all ranges. Suppose that an operating current of 500 microamperes is decided upon, and that the corresponding grid bias is equal to 3 volts. Now suppose further that the cathode resistor for the highest voltage range is equal to 200,000 ohms. Since 500 microamperes flowing through 200,000 ohms will cause a voltage drop of 100 volts, it follows that the bucking voltage required to obtain the desired bias of 3 volts must be equal to 97 volts, with the polarity indicated in Fig. 8-5. The required

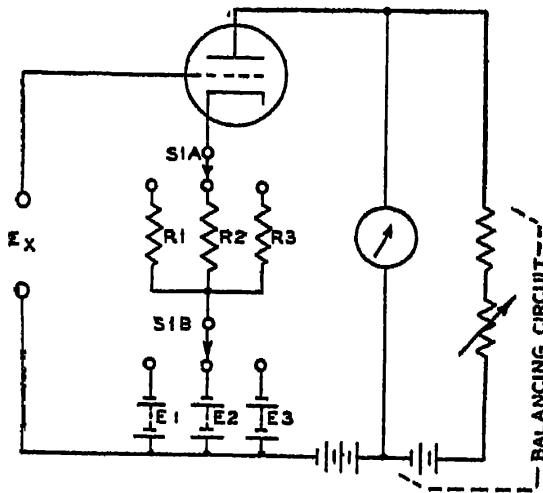

Fig. 8-5. A degenerative d-c amplifier in which the sensitivity is varied by means of S1A. The same operating point is maintained by S1B which changes the bias voltage to compensate for the change in the cathode resistance.

cathode voltage $E1$ for any of the other voltage ranges can be determined in a similar manner. If the same operating plate current is used on all ranges, no change is required in the circuit for balancing the steady plate current. If a smaller value of operating plate current is used on the higher voltage ranges, however, then another section must be used on the range switch to supply the proper value of meter balancing current.

The v-t voltmeter shown in Fig. 5-7 incorporates a d-c amplifier which is basically similar to the degenerative amplifier discussed in this section. The circuit constants shown in this figure are typical of this degenerative type of amplifier which is used in a-c rectifier-amplifier v-t voltmeters as well as in d-c v-t voltmeters.

Balanced Push-Pull D-C V-T Voltmeter

A balanced v-t voltmeter circuit using two tubes is shown in Fig. 8-6. This circuit is unique in that the two cathodes are coupled together through a large value of resistance $R3$. As a result of this common cathode coupling, a large value of $R3$ can be used without the accompanying degeneration which would result in a single-ended circuit. Because large values of $R3$ can be used on the most sensitive ranges without an appreciable reduction in sensitivity, the circuit makes possible increased stability of operation.

The operation of this circuit is as follows: When a positive voltage, for example, is applied to the grid of $V1$, the plate current of $V1$ increases. This increased plate current results in a more positive voltage at the junction K . This positive voltage at K also acts on $V2$

Fig. 8-6. A balanced v-t voltmeter circuit in which stable operation is secured by using a large cathode resistor $R3$ common to both tubes. The polarity switch enables the measurement of positive and negative voltages.

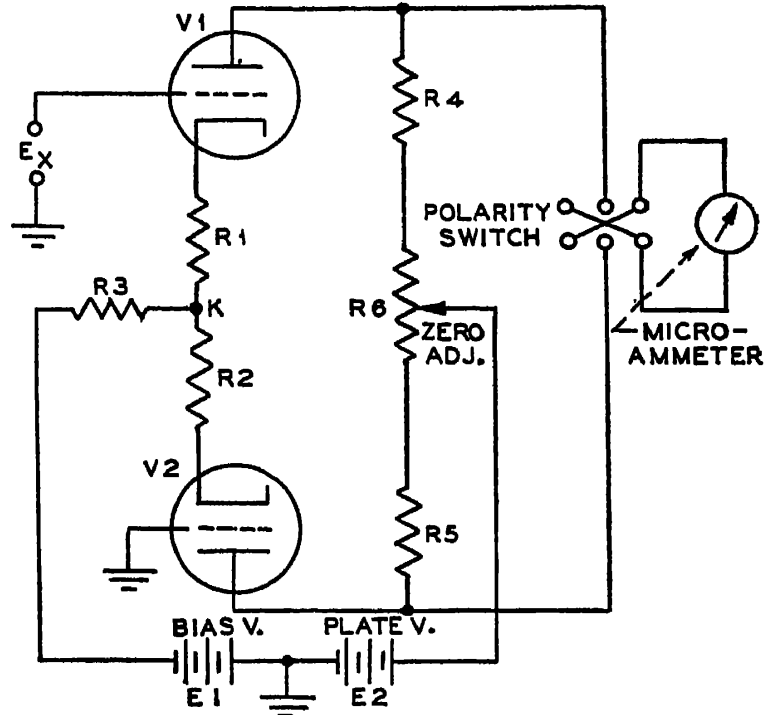

since it tends to make the cathode of $V2$ more positive, and thus tends to decrease the plate current of $V2$. In this way it is evident that the application of a positive voltage to the control grid of $V1$ causes an increase in the plate current of $V1$ and a decrease in the plate current of $V2$. Provided $R3$ is sufficiently large, it can be shown that the decrease in the plate current of $V2$ will be almost equal to the increase in the plate current of $V1$. Because of this push-pull action, the presence of the large value of cathode resistance $R3$ causes a negligible amount of degeneration. At the same time the sensitivity of the amplifier can be varied by inserting resistors in each of the individual cathode circuits, as represented by $R1$ and $R2$.

The manner in which $R3$ contributes to the stability of the circuit can readily be seen. When $R3$ is large, the operating plate current is determined largely by the resistance $R3$ and the bias voltage $E1$. In designing the circuit, the procedure is to decide upon the value of $R3$ and upon the operating plate current. The value of the bias voltage $E1$ should then be fixed at a value such that $E1$ is equal to the voltage drop of the operating plate current through $R3$. Regardless of fluctuations in line voltage or in tube characteristics, the plate current will then "settle down" to this same value of operating current and highly stable operation will result.

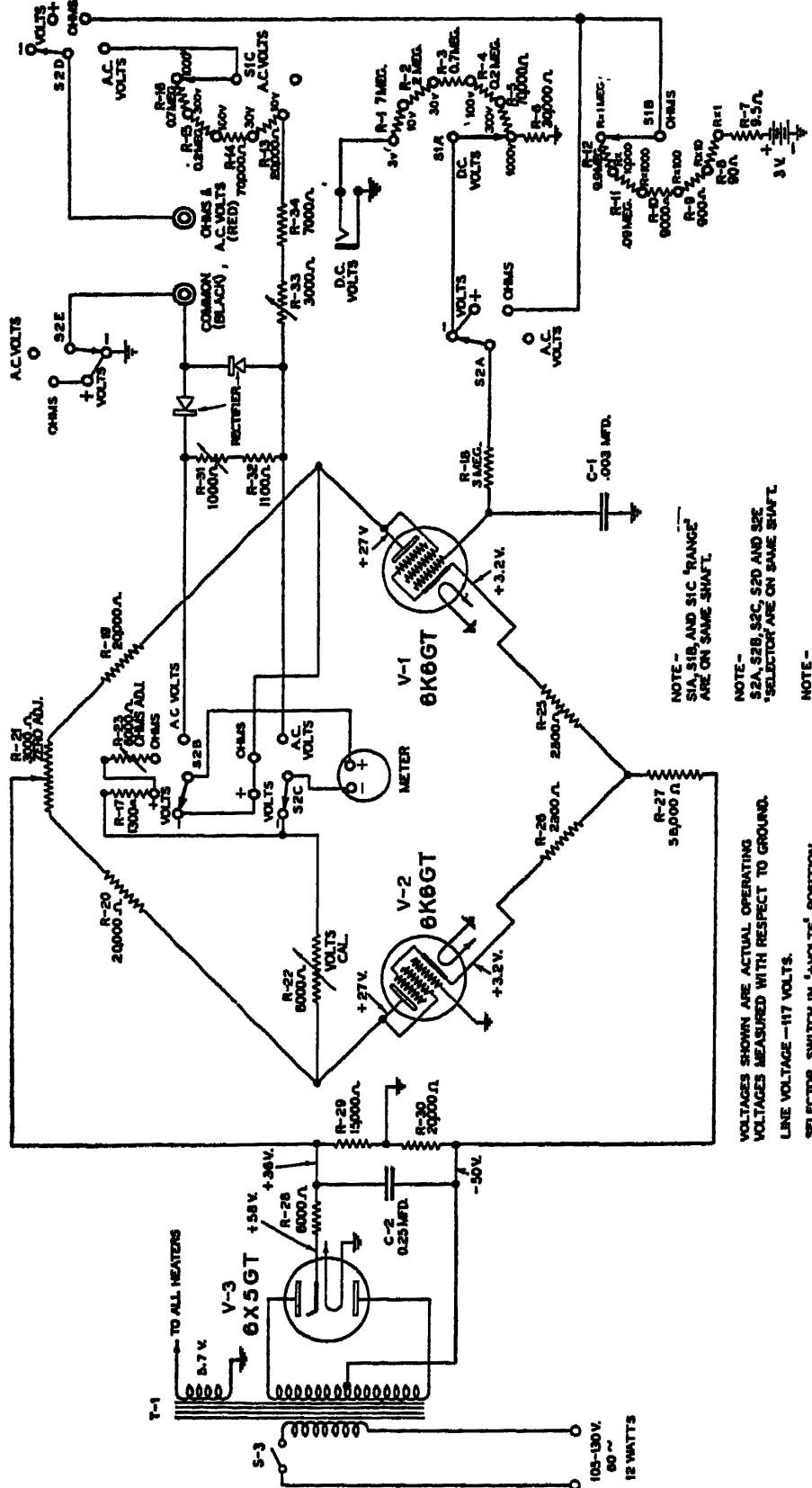

Fig. S-7. Complete schematic of the RCA Junior VoltOhmyst. Courtesy RCA Manufacturing Co., Inc.

A feature of this balanced circuit is that the sensitivity can be changed by varying the resistance of $R1$ and $R2$. When this is done, no auxiliary bias voltage need be changed; the operating plate current will remain essentially constant as the degenerative cathode resistors $R1$ and $R2$ are varied, provided that $R1$ and $R2$ are small in comparison with $R3$. Because the circuit is symmetrical, it follows that the same zero adjustment is maintained on all ranges.

This same type of balanced circuit can also be used with the cathode resistors connected directly to ground in the conventional self-biased circuit. Where this arrangement is used, an auxiliary bias voltage must be introduced either in the grid or cathode circuit in order to keep the operating plate current constant as the cathode resistors are changed.

A polarity switch is provided in the plate circuit so as to enable the measurement of both positive and negative voltages without switching the input leads. The reversal of polarity is accomplished by using a conventional reversing switch which interchanges the connections of the meter to the plates of the two tubes. The value of the plate load resistors is not critical; satisfactory operation will be secured so long as these resistors are large in comparison with the meter resistance.

In common with all balanced v-t voltmeter circuits, the circuit in Fig. 8-6 has the advantage that the zero adjustment is stable and that the meter is not overloaded when the instrument is turned on or off. By choosing a value of operating plate current which is not more than several times the full-scale sensitivity of the meter, damage to the instrument can be prevented even though many times the full-scale voltage is applied to the input terminals.

Where unusually high sensitivity is required, it can be obtained by adding a similar balanced stage of amplification to the circuit shown in Fig. 8-6.

The RCA Junior VoltOhmyst

An instrument using the balanced push-pull circuit previously described is shown in Fig. 8-7. A breakdown of the circuit shows that it is essentially similar to the basic circuit of Fig. 8-6. D-c voltage ranges from 3 volts full-scale to 1000 volts full-scale are obtained by means of a voltage divider in the input circuit consisting of $R1$ - $R6$. Since a special probe with a 1-megohm isolating resistor is supplied with the instrument, the total input resistance is equal to 11 megohms.

The a-c voltage ranges utilize a conventional copper-oxide rectifier circuit which is completely isolated from the a-c line and from the chassis. In addition to the a-c and d-c voltage ranges, the instrument is designed for the measurement of resistances over a range extending from 0.1 ohm to 1000 megohms. This part of the circuit is tied in with the d-c v-t voltmeter and will be explained in the latter part of this chapter in connection with d-c v-t ohmmeters.

Because of the balanced circuit, it is possible to use a relatively simple power supply and filter. A full-wave rectifier is employed which delivers 90 volts through a 6000-ohm filter resistor and an 0.25-mf filter condenser. The voltage applied to the plates of the tubes is about 27 volts, while the voltage applied to the cathode circuit is about 50 volts. This negative voltage of 50 volts in combination with the 56,000-ohm common cathode resistor maintains the plate current of each tube at approximately 500 microamperes. The relatively low value of plate voltage and plate current are utilized in order to reduce the grid current to a very low value which is of the order of 1/10,000 of a microampere. To prevent voltages from reaching the grid, *R18* and *C1* are used as a filter in the grid circuit.

The zero adjustment is made by means of *R21* in the plate circuit. This zero adjustment remains fixed on all the voltage ranges as well as on all the resistance ranges. On the resistance ranges an additional adjustment, *R23*, makes it possible to compensate for variations in the ohmmeter battery voltage so that full-scale deflection will be obtained. An internal adjustment, *R22*, functions as a calibration adjustment to compensate for variations in the circuit constants and in the tube characteristics. This adjustment need be made only when the tubes are replaced. The tube life is extremely long since a low heater voltage (5.7 volts) is used in order to obtain reduced grid current. This low heater voltage is permissible because only 500 microamperes is drawn from a cathode which is capable of delivering more than 100 times this current.

Two switches appear on the panel of the instrument. One of these, the range switch *S1*, enables the selection of the various voltage and resistance ranges. A second, the selector switch *S2*, provides for both positive and negative d-c voltages, and has two additional positions for the measurement of a-c voltages and resistance.

Resistance Measurements with the V-T Voltmeter— V-T Ohmmeters

The d-c v-t voltmeter can readily be adapted to the measurement of d-c resistance over an extremely wide range. A number of different circuits can be used for measuring resistance, but basically all of these methods involve a comparison between the voltage drop across the *unknown resistor* and the voltage drop across a *standard resistor*. Since the two voltage drops are in the same ratio as the two resistances, it follows that the unknown resistance can be determined in terms of the two voltage drops and the known resistance. This basic method has been refined, as will be shown in the following section, so that a d-c v-t voltmeter can be made direct reading in terms of resistance as well as in terms of voltage.

Direct-Reading Vacuum-Tube Ohmmeter

A representative direct-reading vacuum-tube ohmmeter is shown in Fig. 8-8. This ohmmeter circuit may be used with almost any type of d-c v-t voltmeter, although the particular circuit shown is of the balanced type.

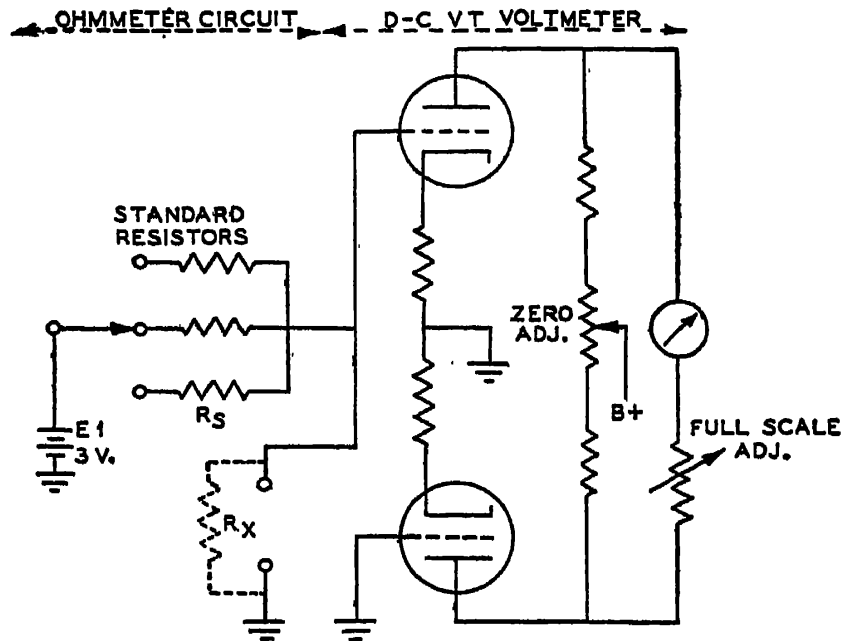

Fig. 8-8. A direct reading v-t ohmmeter circuit. The unknown resistance is determined by measuring the voltage developed across it. A typical scale is shown in Fig. 8-9.

An external battery (1.5 or 3 volts) is used to supply the circuit which consists of a standard resistor R_s in series with the unknown resistor R_x . Initially, before R_x is connected to the input terminals, the sensitivity of the v-t voltmeter is adjusted so that the meter reads full scale. This adjustment may be accomplished by a variable resistor in series with the meter, as illustrated in the figure. Note that with R_x disconnected, the full value of the battery voltage is applied to the v-t voltmeter. Now when R_x is connected across the input terminals, a voltage divider is formed so that only a fraction of the battery voltage reaches the v-t voltmeter. As a result of this voltage division, the reading of the v-t voltmeter is reduced from the full-scale value by an amount which depends upon the resistance connected between the input terminals. Thus it follows that the scale can be calibrated in terms of the resistance required to give any particular scale deflection.

A typical direct-reading ohmmeter scale is shown in Fig. 8-9. The extreme left of this scale—the zero voltage point—also corresponds to a

zero value of R_X since the voltage across R_X is zero when R_X is equal to zero. Similarly, the middle of the voltage scale corresponds to the value of the standard resistor R_S which, for the scale shown, is equal to 10 ohms. The full-scale deflection corresponds to an open circuit or infinite resistance for R_X . Intermediate values of resistance on the voltage scale may be computed by means of the following equation:

$$R_X = R_S \left(\frac{E_V}{E - E_X} \right)$$

Where E = full-scale voltage and E_X = voltage with R_X connected.

The same scale shown in Fig. 8-9 can be used in conjunction with multiplying factors to provide a number of resistance ranges. For example, if standard resistors of 10 ohms, 100 ohms, 1000 ohms, etc., are selected by means of a switch, the corresponding mid-scale values for each of these ranges will be equal to 10 ohms, 100 ohms, 1000 ohms, etc. Thus the same scale can be used in conjunction with various

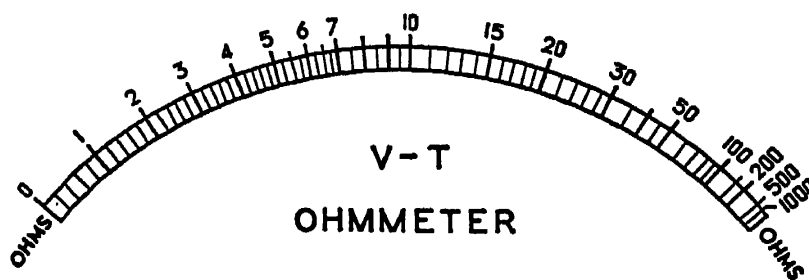

Fig. 8-9. Typical scale of a vacuum-tube ohmmeter using the basic circuit shown in Fig. 8-8. This scale is used in the instrument shown in Fig. 8-7 to cover the range from 0.1 ohm to 1000 megohms.

multiplying factors of $R \times 1$, $R \times 10$, $R \times 100$, etc. A typical circuit of this type is illustrated in Fig. 8-7 which shows the schematic of a commercial combination v-t voltmeter and ohmmeter. In this circuit six standard resistors ranging from 10 ohms to 10 megohms are used, so that mid-scale values from 10 ohms to 10 megohms are provided. Since resistances can be read below and above the mid-scale values, the total range covered is from 0.1 ohm to 1000 megohms.

A feature of this type of ohmmeter circuit is the fact that the adjustments remain constant on all the resistance ranges. Thus the zero adjustment need be made only when the instrument is first turned on, and is completely independent of any part of the ohmmeter circuit. The adjustment for full-scale deflection likewise remains the same for all the resistance ranges since it depends only on the battery voltage.

Unlike the shunt ohmmeter in which the battery will run down rapidly if the instrument is left on, the v-t ohmmeter has the advantage that no current is drawn from the battery except during the actual measurement when the unknown resistor is connected across the input

terminals. Otherwise the current drain on the battery is limited to the grid current of the tube which is entirely negligible since it is a very small fraction of a microampere.

The subject of grid current leads to an important point in connection with the v-t ohmmeter. Unless the grid current is less than 0.01 microampere there will be an error on the high-resistance range where the grid circuit is completed through the comparatively high resistance of the standard R_s . Although it may still be possible to adjust the meter to read full scale, there will be an appreciable error if the grid current is large because the scale calibration will follow a different distribution. In the commercial v-t voltmeter shown in Fig. 8-7, the circuit design is such that the grid current is reduced to a value which is less than 0.0001 microampere on all ranges. As a result of this extremely small grid current, the voltage drop across the standard due to the flow of grid current is negligibly small on even the highest range. (A rapid method by means of which the presence of grid current can be detected is described on page 156.)

Where low-resistance ranges need not be covered, the voltage E_1 in Fig. 8-8 may be supplied from the voltage divider of a power supply. The resistance of the bleeder which supplies the voltage should be small in comparison with the smallest resistance to be measured. As a result of this limitation, it follows that a battery is preferable where resistances smaller than about 1000 ohms are to be measured.

V-T Ohmmeter with External Voltage Supply

Any good v-t voltmeter can readily be adapted so that extremely high values of resistance can be measured by means of an external voltage supply. Although the circuit shown in Fig. 8-10 is not as

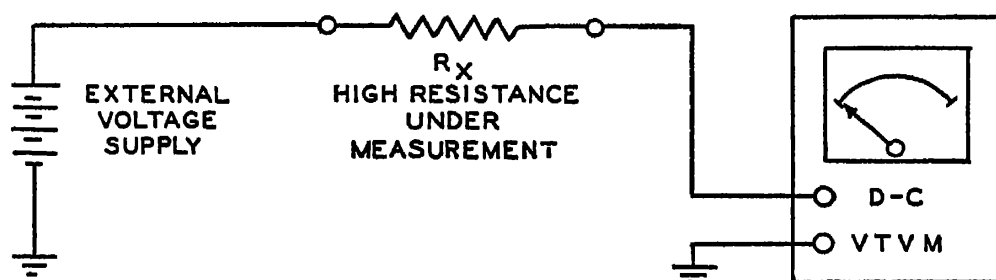

Fig. 8-10. A circuit for measuring high values of resistance by placing the unknown in series with an external voltage supply and a d-c v-t voltmeter.

convenient as the direct-reading ohmmeter circuit previously described, the present circuit has the advantage that much higher values of resistance extending up to approximately 100,000 megohms can be measured.

As shown in Fig. 8-10, the unknown resistance is connected between the high side of an external voltage supply and the input to the v-t voltmeter. The external voltage supply may have any value extending from about 20 volts to 500 volts; the higher values of voltage permit higher values of resistance to be measured. When the connections are made as shown in the figure, the reading of the v-t voltmeter depends on the unknown resistance, the input resistance of the v-t voltmeter, and the external voltage. The unknown resistance can thus be computed by means of the following formula:

$$R_x = R \left(\frac{E1 - E2}{E2} \right)$$

Where $E1$ = External voltage

$E2$ = Reading of v-t voltmeter

R = Input resistance of v-t voltmeter

Where the unknown resistance is large, the voltage developed across the v-t voltmeter is small in comparison with the external voltage so that the formula can be simplified by rewriting it as

$$R_x = R \left(\frac{E1}{E2} \right)$$

A typical example will indicate the manner in which this relation is used. Suppose that the external voltage $E1$ is equal to 500 volts, that the input resistance R of the v-t voltmeter is 10 megohms, and that with a particular value of unknown resistance R_x connected in the circuit, the v-t voltmeter reading is equal to 0.5 volt. Substituting in the above formula, the unknown resistance is equal to

$$R_x = 10 \times \frac{500}{0.5} = 10,000 \text{ megohms}$$

This method is particularly valuable in measuring the leakage resistance of paper and mica condensers. To avoid injury to the meter, the v-t voltmeter should be set on the highest voltage range while the condenser is charging. If this precaution is not followed, the pointer will deflect off scale, since the initial "throw" will correspond approximately to the external voltage. Once the condenser has been charged, the voltmeter reading will steady down to a small value of leakage voltage the value of which will depend upon the leakage resistance of the condenser.

When the leakage resistance of large condensers having a capacitance of several microfarads or more is measured by this method, a considerable period is taken for the condenser to charge to its final voltage. For example, where the condenser capacitance is 10 mf and the input

resistance of the v-t voltmeter is 10 megohms, several minutes will elapse before the leakage voltage reaches its final value. This waiting time can be greatly reduced if the condenser is initially charged by connecting it directly to the external voltage supply.

Use of Guard Terminal—In the measurement of high values of resistance it is frequently necessary to use a *guard* terminal in order to prevent surface leakage from impairing the accuracy. An illustration of the manner in which such a guard terminal is connected when the v-t voltmeter is used for measuring high resistances is shown in Fig. 8-11. In this application, the problem is to measure the leakage re-

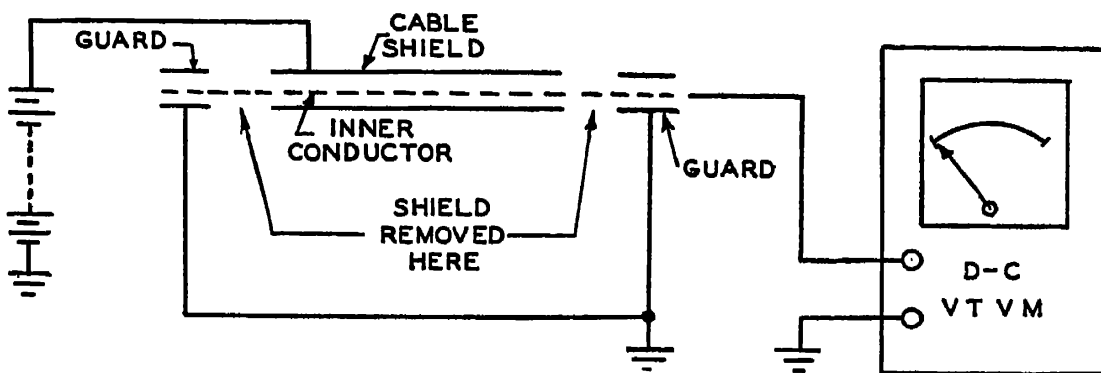

Fig. 8-11. The use of a guard terminal to prevent surface leakage when high values of resistance are measured with the v-t voltmeter.

sistance of a cable. To prevent leakage from the inner conductor over the surface of the cable to the outer sheath, it is customary to strip the shield for at least 18 inches and to wind a conductor over this section, as is shown in the figure.¹ This constitutes the *guard* which should be connected to the common circuit ground. Because of the large voltage difference between the guard and the shield of the cable (the low side of the resistance being checked), and because of the negligible difference in voltage between the inner conductor and the guard, it follows that whatever surface leakage takes place will flow directly to ground and will not affect the accuracy of the measurement. Although the specific application discussed above deals with the measurement of cable leakage, a similar guard ring may also be employed in other measurements where surface leakage must be prevented. It should be noted that no special guard terminal need be brought out from the v-t voltmeter (as in the case of the Megger for example) since the guard connection is made directly to the low or ground terminal of the v-t voltmeter.

¹ A complete description of the necessary precautions to reduce surface leakage will be found in Laws, "Electrical Measurements" McGraw-Hill Book Co.

Slide-Back V-T Ohmmeter for High Resistances

A circuit which is adapted to the measurement of resistances as high as a hundred thousand million million (10^{17} ohms) is shown in Fig. 8-12.¹ This circuit bears a close resemblance to the circuit described

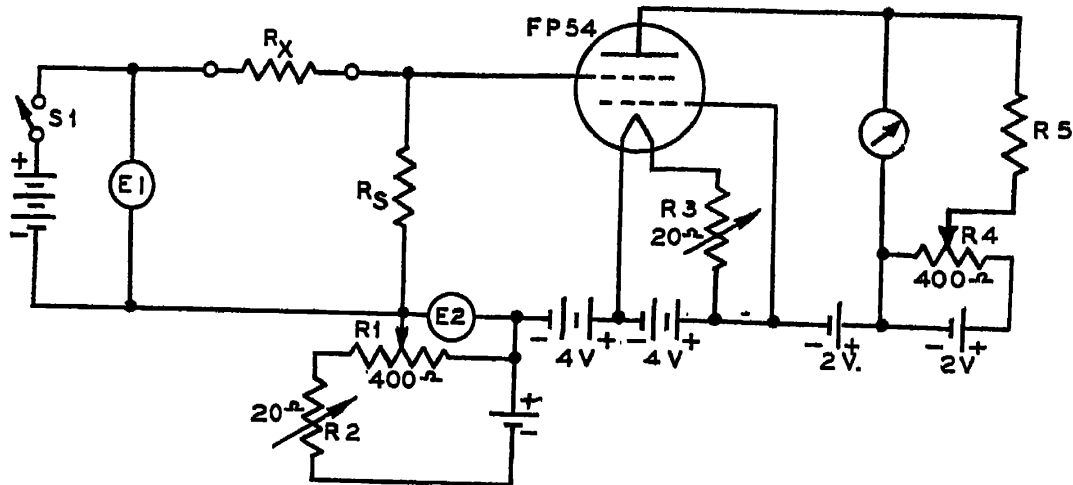

Fig. 8-12. A v-t voltmeter circuit for the measurement of extremely large values of resistance up to 10^{17} ohms. A type FP-54 electrometer tube is used to obtain a high input resistance and low grid current.

in the preceding section but differs from it in two essential respects. First, the v-t voltmeter employs a special General Electric FP-54 electrometer tube which is designed to have a very low grid current and very high input resistance. Secondly, the v-t voltmeter is not calibrated, but instead a slide-back method is used to determine the voltage developed across the v-t voltmeter input. In this way the accuracy is made to depend only on the accuracy of the low-resistance voltmeters used to measure the voltages $E1$ and $E2$. This circuit can of course be used with a conventional d-c v-t voltmeter instead of with the electrometer tube circuit in which case the range is limited only by the grid current and input resistance of the particular vacuum tube employed.

The unknown resistance R_x is placed in series with a standard resistance R_s and a source of voltage $E1$ which may vary up to several hundred volts. The voltage developed across R_s is applied to the input of the v-t voltmeter and since this voltage depends upon R_x , it follows that R_x can be determined in terms of the voltage developed at the input to the v-t voltmeter.

The procedure for making a measurement is to open the switch $S1$, adjust the slide-back potentiometer $R1$ to zero, and to note the gal-

¹Rose, G. M., "A Method for Measuring Very High Values of Resistance," Rev. Scientific Instruments, Dec. 1931, p. 810.

vanometer or microammeter reading. The switch should then be closed so that the voltage $E1$ is applied to the two resistors, and the potentiometer $R1$ adjusted so that the same galvanometer reading is obtained. When this adjustment is made, the unknown resistance R_x can be determined in terms of $E1$, $E2$, and R_s by means of the following relation:

$$R_x = R_s \left(\frac{E1}{E2} - 1 \right)$$

The accuracy of this method depends only upon the accuracy of R_s and the low-resistance voltmeters used to measure $E1$ and $E2$. To cover a wide range, it is recommended that three standard resistors having values of 10^9 , 10^{12} , and 10^{15} ohms be used.¹ Any of the high-resistance standards may be calibrated in terms of a known standard resistor of lower value. The next higher value of standard resistor may then be calibrated in terms of the lower standard just calibrated, and so on up to the highest value of standard resistor.

The circuit shown in Fig. 8-12 can be used with very slight modifications for the measurement of very small direct currents. This application will be discussed later in this chapter.

Sensitive Current Measurements with the D-C V-T Voltmeter

The v-t voltmeter can be readily adapted to the measurement of d-c currents over a very wide range. In this application standard values of resistance are placed in the input circuit of the v-t voltmeter and the unknown value of current interpreted in terms of the voltage drop caused by the current flow through the known input resistor. For example, in the simple circuit shown in Fig. 8-13, suppose that the v-t voltmeter has a full-scale sensitivity of 1 volt, and that three values of standard resistance can be selected by means of the input switch $S1$. When the 10-megohm resistor is shunted across the input, the meter will read full scale for a current of only 0.1 microampere. Similarly, on the other two ranges shown, full-scale deflection will be obtained for currents of 1 microampere and 10 microamperes. By using lower values of input resistance, larger values of current can be measured.

Using the basic circuit just described, v-t microammeters have been designed which have numerous advantages over the relatively delicate suspension type galvanometers used for measuring small currents. These advantages include greater sensitivity, ruggedness, lower cost, portability, and greater speed of measurement. The accuracy which can be secured is as good or better than can be obtained by other methods.

¹Suitable resistors, which are supplied with a calibration giving the exact value, can be obtained from the S. S. White Dental Mfg. Co., Industrial Division.

With the v-t voltmeter type of microammeter there is always a voltage drop across the input which depends upon the sensitivity of the v-t voltmeter. Ordinarily the drop of approximately 1 volt or less required for full-scale deflection is not objectionable in circuits which

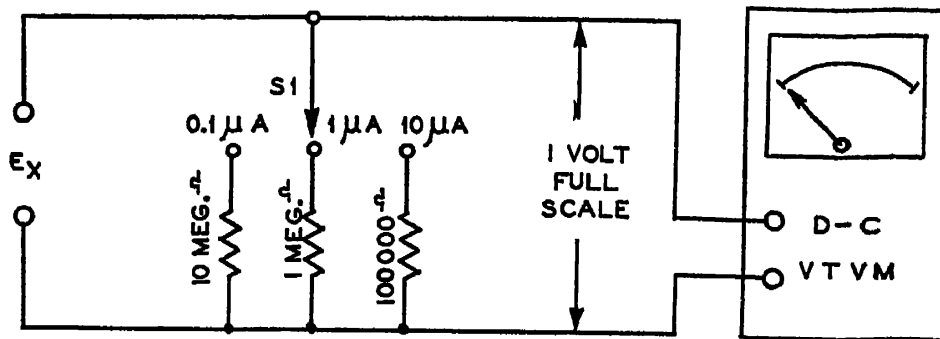

Fig. 8-13. The v-t voltmeter can be used as a sensitive microammeter by placing standard values of resistance in the input circuit and interpreting the voltage developed across these resistors in terms of the unknown current.

carry small currents. In special applications which require a lower voltage drop, it is possible to use v-t voltmeters which give a full-scale deflection for approximately 0.1 volt or less.

Degenerative V-T Microammeter and Voltmeters

The basic circuit of an amplifier which has been used in multi-range d-c v-t voltmeters and microammeters is shown in Fig. 8-14.¹ This circuit employs a high-gain direct-coupled amplifier the output of which is fed back to the input so that degeneration is produced. As a result of the 100% feedback employed, the circuit is extremely stable and a high degree of accuracy is secured.

An analysis of this circuit shows that the voltage developed across the load resistor of the final amplifier tube will be equal within very close limits to the voltage which is applied to the input terminals. For example, if the gain of the amplifier is 1000, then the voltage indicated by the voltmeter V will be less than the input voltage by only 1 part in 1000 or by less than 0.1%. Furthermore, because the gain is so much greater than 1, it follows that the output voltage will remain essentially equal to the input voltage over a wide range of variations in the circuit constants and tube characteristics. This may readily be seen, for if the amplification should change from say 1000 to 500, a change of 2 to 1, the only effect would be to cause an error in the voltmeter reading of about 0.1%.

¹Vance, A. W., "An Improved Vacuum-Tube Microammeter," Rev. Scientific Instruments, Dec. 1936, p. 489.

Since amplifiers of this type using inverse feedback show a tendency toward high-frequency oscillation, some means must be taken to sup-

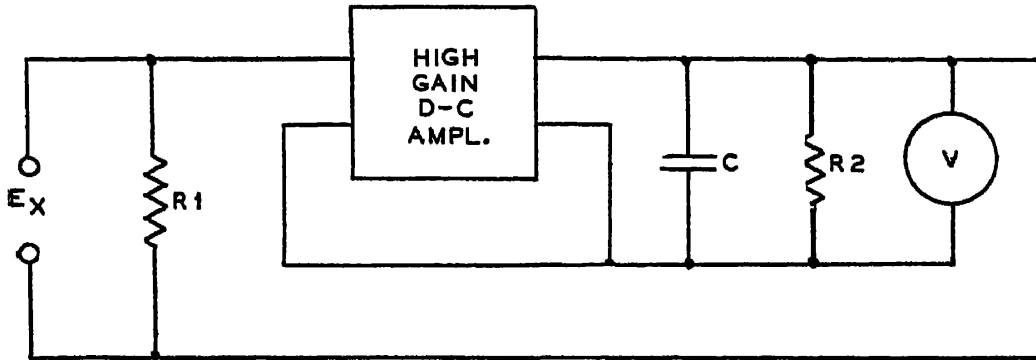

Fig. 8-14. The basic circuit of a degenerative direct-coupled amplifier which is used in v-t voltmeters and microammeters. 100% feedback is secured by coupling the voltage developed across the output back to the input.

press this oscillation. A method employed for preventing oscillation is to shunt the output load resistor with a large condenser as is indicated by C in Fig. 8-14.

A Multi-Range Microammeter Using Inverse Feedback

A practical circuit using a direct-coupled amplifier of the type discussed in the preceding section is shown in Fig. 8-15.¹ A three-stage battery-operated amplifier having an overall voltage gain of 5000 is employed. As in the basic circuit of Fig. 8-14, the voltage developed across the 10,000-ohm output resistor is fed back to the cathode of the input tube so that 100% negative feedback is secured. With no voltage applied to the input terminals, the amplifier locks in at a stable operating point such that the drop across the 10,000-ohm load resistor is equal to about 1.4 volts. A 1.5-volt cell and potentiometer are used to balance out this voltage so that the voltmeter reads zero.

The input circuit is arranged to provide full-scale current ranges extending from 0.01 microampere to 1000 microamperes. The several ranges are obtained by inserting different values of resistance in the input circuit. These values range from 10 megohms to 1000 megohms. Lower values of resistance could be used to increase the current range, but this is not practical since such measurements can be made more simply by using a conventional milliammeter.

The multi-range microammeter circuit shown in Fig. 8-15 can also be arranged so either voltage or resistance can be measured simply

¹ See reference on page 130.

by changing the input circuit.¹ A voltage-divider arrangement must be used for voltage measurements since the sensitivity cannot be varied over a wide range by changing the sensitivity of the voltmeter used to measure the feedback voltage.

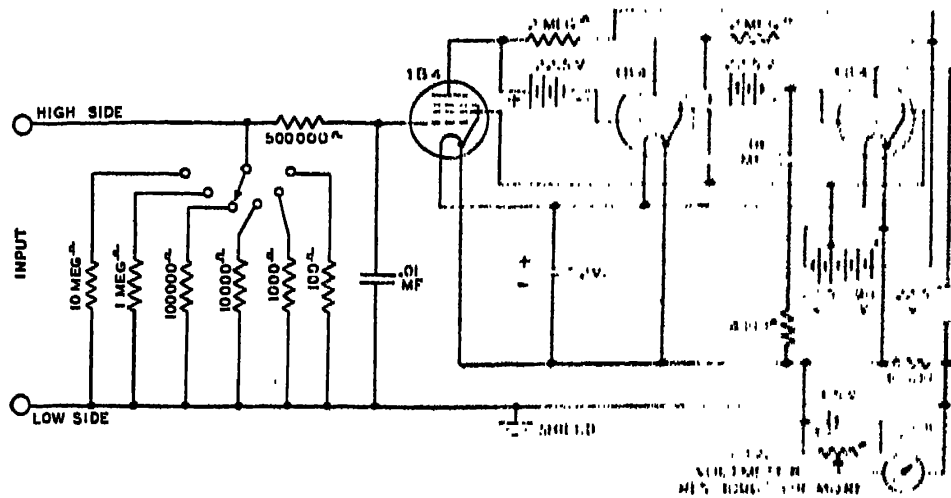

Fig. 8-15. A multi-range v-t microammeter employing a three-stage direct-coupled amplifier. See Fig. 8-14 for the basic circuit.

The basic circuit shown in Fig. 8-14 can also be adapted to a-c operation. In one commercial instrument which was designed primarily for recording small d-c voltages, a three-stage a-c operated amplifier is used to obtain full-scale deflection on a 5-milliamper meter for an input voltage of only 0.1 volt. Although designed primarily for operating a recorder, this amplifier may also be used as a v-t voltmeter by the provision of a voltage divider in the input circuit.²

Ultra-Sensitive Current Measurements

The measurement of currents smaller than about 0.001 microampere requires the use of special electrometer vacuum tubes which are designed to have an extremely low grid current and high input resistance. The General Electric FP-54 Pliotron is suitable for such measurements. This tube uses a special type of construction by means of which it has been possible to reduce the grid current to about 10^{-12} ampere and to raise the input resistance to approximately 10^{10} ohms. A circuit similar to that shown in Fig. 8-12 may be used for the measurements of extremely small current down to as low as 10^{-14} ampere. Many other circuits have been devised which employ special means to obtain the necessary degree of stability.

¹Brumbaugh, J. M. and Vance, A. W., "A Feedback D-C Meter," *Electronics*, Sept. 1938, p. 16.

²Clapp, J. K., "A-C Operated D-C Amplifier for Industrial Use," *Gen. Radio Experimenter*, Feb. 1939.

Chapter IX

DESIGN AND CONSTRUCTION OF VACUUM-TUBE VOLTMETERS

IN THIS chapter the general consideration relating to the design and construction of v-t voltmeters will be covered, particular emphasis being given to the most desirable operating characteristics. What to look for in a v-t voltmeter and how to design the circuit so as to obtain the desired features are some of the considerations discussed in this chapter.

High Input Impedance

One of the most desirable characteristics of a v-t voltmeter is that it have a very high input impedance. Not only does this result in a minimum reaction on the circuits under test, but in addition it makes it possible to use the v-t voltmeter for making measurements of inductance, capacitance, Q of coils and condensers, and for countless other applications where high input impedance is essential. The most effective method for obtaining a high input impedance is to mount the tube at the end of a probe so as to permit short leads to the circuit under test. This type of construction has already been described in detail. The use of an acorn type tube to raise the input impedance at high frequencies will be discussed on page 136.

Wide Frequency Range

For obvious reasons, it is desirable that the frequency range be made as great as possible, consistent with other considerations. Preferably, for general purpose v-t voltmeters, the frequency range should extend from about 30 cycles to 100 megacycles. A lower limit of 60 cycles should be considered almost indispensable since it enables the calibration of the v-t voltmeter at 60 cycles. In this connection the use of an acorn type input tube is essential if measurements above about 30 megacycles are to be made.

Wide Voltage Range

For the general run of measurements, a range from about 1 volt full scale to 100 volts full scale is desirable. This range should be covered in steps not greater than about 3 to 1 in order to provide sufficient overlapping. Over this range a direct calibration should be provided by means of multiple scales on the same meter face. The scale for the lowest voltage range, which has the poorest accuracy, should be arranged on the innermost arc (shortest scale).

The usefulness of the v-t voltmeter can be extended appreciably by providing a low-voltage range which has a full-scale value of several tenths of a volt. While it may not be feasible to calibrate this range directly, it can be calibrated in terms of the outer scale which is usually linear. The stability of this sensitive range will be relatively poor, but it is very useful nevertheless and its accuracy can always be made as high as desired by using it as a comparison v-t voltmeter (see p. 153).

Accuracy and Permanence of Calibration

V-t voltmeter design has progressed to the point where a direct calibration can be readily secured and can be considered an almost indispensable convenience. A full-scale accuracy of about 2% can be expected with the usual type of design. The extent to which the original calibration will hold over a period of time depends very greatly on the design and construction. For example, grid rectification v-t voltmeters are notoriously unstable, while the rectifier-amplifier type is relatively stable provided that sufficient degeneration is used in the d-c amplifier circuit. The use of a voltage-regulated power supply is usually an important factor in promoting accuracy and permanence of calibration, although in some balanced amplifier circuits voltage regulation is not essential. In most a-c v-t voltmeter circuits, especially those of the rectifier-amplifier type, regulation of the heater as well as the plate voltage is desirable. The use of a relatively sensitive meter of about 100 or 200 microamperes full scale is desirable since this enables the use of additional degeneration which would not be possible were a less sensitive meter to be used.

Type of Response—Waveform Error

Since the true rms v-t voltmeter is extremely difficult to design so that it will function over a wide range of voltages, it is general practice to employ a peak-reading v-t voltmeter for most measurement. Although these v-t voltmeters are usually calibrated to read rms values, their reading can always be interpreted in terms of the peak or average value of the wave being measured. Thus the inherent peak response of such a v-t voltmeter is useful for many applications. Considering that the number of applications where a true rms response is required is rather limited and the difficulty of designing a wide range square-law v-t voltmeter, it is preferable to use specially designed v-t voltmeters for such applications, and to use the peak-reading rectifier-amplifier type for a general purpose instrument.

Stability and Protection Against Overload

An important consideration in v-t voltmeters is that of stability and protection against overload. This is related to the question of per-

manence of calibration and the same steps taken to secure that feature will also promote stable operation. Among the factors which tend to improve the stability and prevent shifting of the zero may be included the following: The use of a balanced circuit, regulation of the power supply (including heater voltage when required), and the use of an operating plate current which is not excessively large in comparison with the full-scale meter current.

Adequate protection against overloading of the meter should be provided. This can be done by designing the circuit to operate with a low value of operating plate current, as described in the preceding paragraph. The inclusion of a resistor in series with the grid of the d-c amplifier tube is a simple but effective means for preventing the grid from being driven positive when a heavy overload occurs. With proper design, it is possible to prevent the current through the meter from exceeding about three times the full-scale meter current. This provides adequate protection against meter injury.

Simplicity of Design and Ease of Operation

As in all instrument design, simplicity of design and ease of operation are highly desirable features. The number of controls appearing on the panel should be limited to those which are absolutely required, and in addition they should be grouped so as to secure the greatest convenience of operation. In certain applications, portability is a desirable feature and for such applications the design may advantageously be built around the new 1.4-volt tubes which can be operated directly from a 1.5-volt cell. These tubes also require a minimum of plate voltage for satisfactory operation.

Compensating for the Effect of Variations

It must always be expected that variations will occur in the values of the various resistors, condensers, voltages, etc., which constitute the nominal design values. For example, variation in the heater voltage will usually cause an appreciable shift in the zero reading. The amount of this variation must be checked and due allowance made so that the instrument will function satisfactorily over a reasonable range of line voltages. Similarly, in degenerative amplifiers some resistors are more critical than others. Thus the cathode resistor determines the sensitivity of the amplifier so that an accurate wire-wound resistor should be used. In some balanced v-t voltmeters it may not be necessary to provide a regulated power supply because of the inherent symmetry and stability of the circuit. These are typical illustrations of the many factors that should always be investigated so that due allowance is made for the variations which will be encountered in operation.

Reducing Errors at High Frequencies

With the increasing importance of frequencies above 30 megacycles, it is very desirable that a general purpose v-t voltmeter be of the probe type so as to permit operation at these frequencies with a minimum of error. Even at low radio frequencies, the probe type of construction is a decided advantage because of the lower input capacitance which can be realized and because of the prevention of feedback as a result of long leads to the v-t voltmeter. At high radio frequencies the probe type of construction is an absolute necessity because leads longer than an inch or so give rise to resonance effects which make measurements impossible.

INPUT RESISTANCE TABLE. Fig. 9-1

| <i>Tube Type</i> | <i>15 mc</i> | <i>30 mc</i> | <i>100 mc</i> |
|------------------|--------------|--------------|---------------|
| 6J7 | 66,000 ohms | 19,000 ohms | 1,900 ohms |
| 954 (Acorn) | 940,000 | 220,000 | 20,000 |

The use of an acorn type tube is very desirable if the minimum error is to be secured at frequencies above about 15 or 20 megacycles. At high radio frequencies where the electron transit time in the space between the elements of the vacuum tube is comparable to the time of one r-f cycle, the input resistance of the ordinary receiving tube becomes very low. This excessive loading can be reduced to about one tenth the value for the ordinary receiving tube by using an acorn tube. The table in Fig. 9-1 shows the considerable increase in input resistance which can be obtained by using an acorn tube as compared with the conventional receiving type tube of which the 6J7 is representative.

To enable measurements above several hundred megacycles, special experimental diode tubes have been developed. These tubes have an extremely small spacing between elements so as to reduce the transit time effect and thus reduce the loading.¹

V-t voltmeters using resistor type voltage dividers in the r-f input circuit have in a number of instances been represented as being suitable for use at radio frequencies. It should be clearly understood that such voltage dividers are ordinary inaccurate at frequencies above about 10 kilocycles. Where special precautions are taken, and capacitance compensation is used as in Fig. 7-3, the divider can be made accurate up to about 500 kilocycles, but this represents about the upper frequency limit at which such dividers will operate.

¹ Megaw, E. C. S., "Voltage Measurements at Very High Frequencies," *Wireless Engineer*, Feb. 1936, p. 65; March, 1936, p. 135; April 1936, p. 201.

Bypassing Considerations

To secure accuracy over a wide frequency range, it is essential that the various circuit elements be adequately bypassed. As in all radio circuits, the bypass condenser should be large enough so that its reactance is small in comparison with the circuit element which is being bypassed. Thus the reactance of the plate bypass condenser, for example, should be small in comparison with the plate resistance of the tube. In general purpose v-t voltmeters covering a wide frequency range down to about 60 cycles, it is impossible to secure proper bypassing by means of a single condenser. A large condenser having sufficient capacitance to bypass at 60 cycles has too much inductance to be effective at high radio frequencies; in addition, it is too bulky to be placed close enough to the points which are to be bypassed. This limitation is usually overcome by using a small mica condenser directly at the tube elements for the higher radio frequencies, in parallel with a large paper (or electrolytic condenser in special cases) which can be mounted at any convenient place since the lead length is not critical. In probe type v-t voltmeters the usual practice is to use 0.01-mf mica condensers mounted directly at the tube socket in the probe head, while larger condensers are shunted in parallel with these and mounted in the main instrument case assembly. For an example of this type of construction see Figs. 5-7 and 5-8.

Where electrolytic condensers are used in v-t voltmeters, as for example in bypassing the cathode resistor in a reflex v-t voltmeter, it is advisable to use a higher voltage electrolytic than is called for by the working voltage. This will reduce the leakage current of the electrolytic so that the calibration will not be affected.

Selection of Tubes

The factors on which a particular tube is selected for use in a v-t voltmeter include the following: input capacitance, high-frequency losses (input resistance), mutual conductance, amplification factor, and heater or filament voltage. In d-c v-t voltmeters, grid current or contact potential is a very important factor since it determines the effective input resistance of the v-t voltmeter.

The desired tube characteristics will vary considerably with the type of v-t voltmeter under consideration, the range to be covered, whether square-law response is required, etc. In plate rectification v-t voltmeters it is generally true that tubes having a low amplification factor and a high mutual conductance are most suitable. Where a relatively high voltage is covered on the lowest range, it is usually desirable to use a tube having a low amplification factor so that a high cut-off voltage will be obtained with relatively low values of plate voltage.

In diode type v-t voltmeters, it is usually preferable to employ a triode connected as a diode. This makes it possible to bring the input terminal to the top cap of the tube, the cathode and plate being connected and used as one element of the diode and the control grid as the other element. Where an acorn tube is used, this practice is invariably followed since there is no separate diode available at present among commercial acorn tubes.

Because of the present tendency toward single-ended tubes, it is becoming increasingly difficult to obtain triodes which have the control grid on top. In cases of this type a suitable pentode can usually be found. For example, in the 1.4-volt series, the most suitable tube for use as a diode with the control grid on top, is the type 1N5-GT pentode which can readily be used as a diode by using the control grid as one element, and the cathode, screen, and plate tied together as the other element. Single-ended tubes can also be used as diodes in the same way, although usually they are not so convenient for probe type v-t voltmeters.

The relatively new "button" type tubes should not be overlooked when selecting a tube for v-t voltmeter applications. These tubes are considerably smaller than the conventional receiving tubes, and thus are especially suitable for v-t voltmeters.

In general screen-grid and pentode tubes (used as such) should be avoided in v-t voltmeter design since they unnecessarily complicate the circuit by requiring additional components and voltages. Usually they do not make possible improved performance, although in certain special applications they offer greater flexibility than can be obtained with a triode. An example of such an application is the design of a square-law v-t voltmeter where operation of the screen at the proper voltage enables the production of an almost perfect square-law characteristic.¹

Although high- μ triodes are not very suitable for use in plate-rectification v-t voltmeters, they can be used to advantage in the d-c amplifier section of v-t voltmeters. In this application they provide a relatively high value of mutual conductance at small values of operating current. This feature makes them particularly useful in degenerative d-c amplifiers such as are used in rectifier-amplifier v-t voltmeters. In general, however, high- μ triodes are not suitable for use in the input stage of d-c v-t voltmeters where it is necessary to obtain high values of input resistance and very low grid current.

Selection of the Meter

In most v-t voltmeter circuits, it is desirable to use a relatively sensitive meter of the order of 100 or 200 microamperes full scale. The

¹Ragazzini, J. R. and Boymel, B. R., "A Square-Law Vacuum-Tube Voltmeter," *Rev. Sci. Instruments*, Oct. 1940, p. 312.

use of a sensitive meter is desirable because it raises the maximum sensitivity and at the same time permits the use of a greater amount of degeneration on the higher ranges. The development of the d-c moving-coil meter has progressed to the point where a 100-microampere meter is no longer considered a very sensitive meter and to the point where such meters are less expensive and considerably more rugged than they were formerly. In this connection 50-microampere meters are in common use in ordinary analyzer units, and in such service the meter does not have the protection afforded by the v-t voltmeter circuit. This lack of adequate overload protection which is overcome in v-t voltmeter design has been a serious limitation on the use of sensitive meters in ordinary applications.

Where the greatest sensitivity and accuracy of calibration are not required, an appreciable reduction in cost can be secured by designing the circuit so that a milliammeter rather than a microammeter can be employed. This can be done by operating the tube so that the maximum sensitivity is secured. Under such operating conditions it is ordinarily not possible to use an appreciable amount of degeneration.

Resistor Considerations

To secure the greatest permanence in calibration, it is desirable that wire-wound resistors be used at all points in the circuit where the resistance must be held to within close limits. For example, the cathode resistors which determine the sensitivity by controlling the amount of degeneration should be wire wound. On the other hand, there are many points in the v-t voltmeter circuit where a change in the resistance value will not affect the calibration and in such places resistors of the metallized type may be used to effect a considerable reduction in the cost. A typical place where metallized resistors can be used is in the balancing circuit, where a change in resistance over a period of time can be readily compensated by changing the zero adjustment control. In the lower values of resistance up to a few thousand ohms there is relatively little difference between the cost of metallized and wire-wound resistors.

High-Resistance Values—The higher values of resistance required in the voltage dividers of d-c v-t voltmeters present a problem since wire-wound resistors are not available in values above about 10 megohms; in fact, even in the range between 1 megohm and 10 megohms, the cost is prohibitive except for precision laboratory instruments. The practice is to use metallized resistors which are usually matched in pairs to within 1%. Thus a 10-megohm resistor can be made up of two 5-megohm resistors in series. If one 5-megohm resistor is high by 6%, for example, and the other 5-megohm resistor is low by 6%, then it follows that the 10-megohm resistor will be accurate to within 1%.

Unfortunately this method of obtaining 1% resistors is usually limited to manufacturers since it requires a large stock of resistors.

High-Voltage Resistors—Special high-voltage resistors suitable for extending the voltage range of d-c v-t voltmeters up to about 10,000 volts are available. In one type of high-voltage resistor manufactured by the International Resistance Company, the resistor consists of a spiral element on a tubular form, so as to obtain a long effective resistance path without an objectionable increase in the overall length of the resistor. These resistors can be obtained in values as high as 10,000 megohms. The temperature coefficient increases with the resistance value, being approximately 0.2% per degree Centigrade for the higher values. A voltage rating of 5000 volts d. c. can be obtained in a resistor 2 inches long, while a voltage rating of 25,000 volts can be obtained in a resistor $6\frac{1}{2}$ inches long.

Slide-Back Voltage Dividers—In slide-back v-t voltmeters, no particular care is required in the design of the voltage dividers which supply the balancing voltage. The only requirement is that the desired voltage range be covered, since the accuracy of the measurement depends upon the accuracy of the d-c voltmeter used to measure the slide-back voltage. In general the resistance of the slide-back voltage divider should be small in comparison with the resistance of the d-c voltmeter. Since a 1000 ohm-per-volt meter is generally used, this requirement calls for a voltage divider which has a resistance of about 200 ohms-per-volt. Accordingly, a voltage divider for a 250-volt supply would have a total resistance of 200×250 or 50,000 ohms.

Grid-Circuit Considerations

Regardless of the type of v-t voltmeter, the input circuit must provide a continuous d-c path between the control grid and the cathode. In a-c v-t voltmeters it is usually desirable to have a blocking condenser in the input so that the reading will not be affected by any d-c voltage present. An additional reason for the desirability of a blocking condenser in a-c v-t voltmeters is that possible error as the result of a variation in "contact potential" is prevented, since the total resistance in the grid circuit remains constant when a blocking condenser is used. The value of the grid resistor should be large enough so that the loading effect is not excessive and at the same time should not be too large or erratic operation will result. The relation between the coupling condenser and grid resistor should be such that the reactance of the coupling condenser is small in comparison with the resistance of the grid leak (see Fig. 2-12).

When an a-c v-t voltmeter is used without a coupling condenser, the zero reading will usually shift somewhat when the d-c resistance of the circuit being measured is higher than a few hundred thousand ohms.

To prevent error from this source, the zero should be checked while the instrument is connected to the circuit under test. To check the zero it is necessary to cut off the a-c voltage in some way, for example by temporarily shunting a condenser across the input, or by turning off the power in the circuit under test. Of course there should be no d-c voltage present in the circuit under test or an error will be introduced. The advantage in designing the input circuit so that a direct connection can be made to the grid is that the loading effect introduced by the grid leak is eliminated. In addition, the omission of the grid condenser shortens the effective length of the input circuit so that measurements can be made at a higher frequency. Both of these considerations are important in relatively few applications, and in general it is preferable to work with a grid condenser and resistor connected semi-permanently or permanently in the input circuit.

In d-c v-t voltmeters it has previously been pointed out that the input circuit must be designed so that the grid current is held to a minimum. Among the factors which must be considered in obtaining this high input resistance are the choice of the proper tube, low plate and heater voltages, and proper layout to avoid leakages.

Reduction of Leakage in D-C V-T Voltmeters and V-T Ohmmeters

The proper operation of d-c v-t voltmeters and v-t ohmmeters depends not only upon the use of a suitable tube type and circuit, but also upon proper layout so that leakage effects are prevented from introducing an error. Paradoxical as it may seem, a metal or conducting panel is indispensable if leakages are to be avoided. When a metal panel is used, the panel acts as a guard ring so that whatever leakages take place are prevented from developing a voltage across the high-resistance input circuit of the v-t voltmeter or ohmmeter. In combination v-t volt-ohmmeters, the switch layout should be made so that separate switch sections (wafers) are used for switching the high-resistance input circuits. No leads which contain voltages either above or below ground potential should appear on these switch sections; separate sections on the same gang should be provided for handling these leads. Too much care cannot be exercised in observing this precaution. The switch wafers themselves should preferably be of wax-impregnated hard rubber, since this dielectric has a lower d-c leakage than the bakelite wafers ordinarily used for wave-band switches. The latter switches will usually function quite satisfactorily, however, and can be used where it is not possible to obtain the hard-rubber variety; the latter is usually available only to instrument manufacturers who can place a quantity order.

In high-resistance input circuits, surface leakage can be reduced by using a coating of ceresin wax. The practice of dipping high-resistance units in wax to reduce surface leakage is often followed. Where the control grid of the input circuit is the top cap of a tube, surface leakage over the glass can be reduced by coating the glass with ceresin wax.

Power Supply Considerations

The ideal power supply for v-t voltmeters is one which supplies completely regulated plate and heater voltages. Although this is desirable, it is not always essential that a regulated supply be used, and the extent to which regulation is required depends upon the particular circuit, whether or not it is balanced, its sensitivity, etc. In some circuits no regulation is required, whereas in others complete regulation of both plate and heater voltages is required.

A simple circuit using a neon-tube regulator or a gaseous regulator tube of the VR-150 type is shown in Fig. 9-2. This circuit is suitable

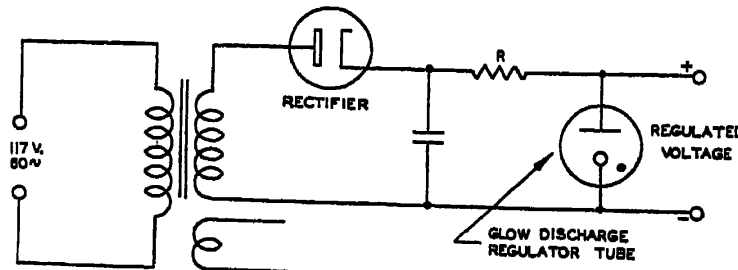

Fig. 9-2. A simple voltage-regulated power supply in which regulated plate voltage is secured by using a large resistance R in series with a neon tube or gaseous regulator tube such as the VR-150.

in applications where only the plate voltage need be regulated. To secure a good degree of regulation, the voltage supplied by the transformer should be about twice the desired output voltage; this permits a large value of R to be used. Relatively little filtering is ordinarily required since the regulator tube contributes to the filtering of the output. The resistor R should be chosen so that the current drawn by the regulator tube is near the middle of the operating characteristic as specified by the tube manufacturer.

Any one of the small neon tubes can be used satisfactorily in this type of circuit to obtain about 60 volts of regulated plate voltage at a few milliamperes of output current. These neon tubes are now available without a current-limiting resistor in the base. If the latter type is used, the tube must be debased, the resistor removed, and the base recemented. Since the latter procedure is time consuming, it is recommended that the resistor-less type of neon tube be used. Where either higher voltages or higher output current is required than is available from a neon tube, one or more VR-105 or VR-150 tubes may be used.

Completely Regulated Voltage Supply

A power supply which is particularly suitable where regulation of the plate and heater voltage is required is shown in Fig. 9-3.¹ In this

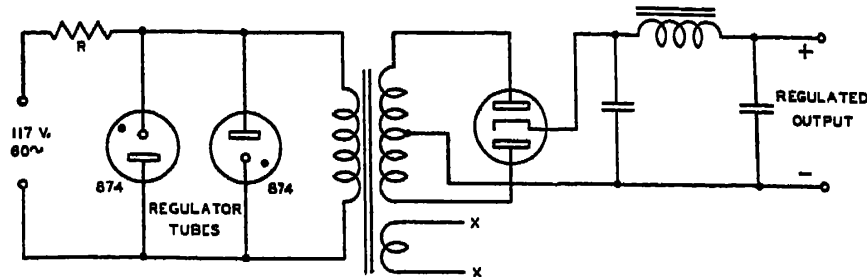

Fig. 9-3. Regulation of both the plate and filament voltages is secured by regulating the voltage applied to the primary of the power transformer. Note that the polarity of the two regulator tubes is reversed so that both halves of the cycles are regulated.

circuit, two type 874 regulator tubes are used in the primary circuit to regulate both the positive and negative half cycles of the voltage applied to the primary of the power transformer. To obtain good regulation, R should have the largest value which will permit ignition of the regulator tubes on the lowest line voltage encountered. Since the regulator tubes reduce the primary voltage, the output voltages will be lower than if a conventional circuit were used. If a special transformer is used, due allowance can be made for this drop. A regular transformer, however, can readily be adapted so that the desired voltages will be obtained. A suitable voltage divider can be used to obtain the desired plate voltage, while the reduced heater voltage can be used directly in most cases, or else the 5-volt filament winding can be placed in series with the 2.5-volt winding. Because of the small emission required in most v-t voltmeter circuits, it is usually practical to operate at a heater voltage as low as 4 or 5 volts. As previously pointed out, this has the advantage of providing longer tube life and lower grid current.

Extending the Voltage Range of A-C V-T Voltmeters

In many applications, especially in transmitter engineering and maintenance, it is often necessary to measure voltages greater than about 100 volts which is usually the upper limit of the conventional general purpose v-t voltmeter. There are two general ways of accomplishing this. One is by using a high-voltage rectifier tube such as a type 2X2 (see Fig. 2-11) to rectify the voltage, and then to measure

¹Lampkin, G. F., "A Simple A-C Voltage Regulator," *Electronics*, Aug. 1937, p. 30.

the rectified voltage with a d-c v-t voltmeter or microammeter. The other method, which will be described below, is to use a capacitive type multiplier which is attached directly to the input of the a-c v-t voltmeter.

The basic circuit for such a capacitive multiplier is shown in Fig. 9-4. The multiplier shown provides a factor of 10, so that a v-t voltmeter reading up to 100 volts could be used to measure voltages up to 1000 volts. The multiplier consists of a small input condenser of 5 mmf which is in series with the input capacitance of the v-t voltmeter. A supplementary condenser must be added in shunt with the input of the v-t voltmeter in order to raise the input capacitance (of the v-t voltmeter) to 45 mmf. In this way the voltage reaching the v-t voltmeter is reduced to $\frac{1}{10}$ of the total input voltage.

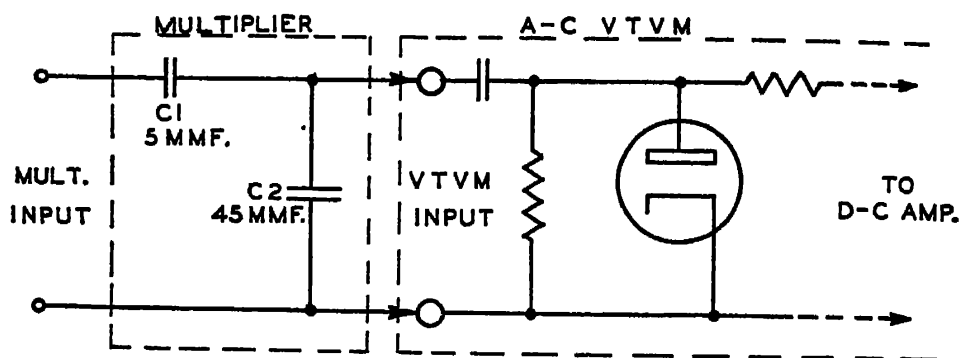

Fig. 9-4. A capacitive type of multiplier which can be used to extend the voltage range of a-c v-t voltmeters.

A multiplier of this type will ordinarily be accurate over a frequency range extending from about 1 megacycle to 100 megacycles. The lower frequency limit depends upon the input resistance of the v-t voltmeter; the higher the input resistance, the lower is the frequency at which the multiplier will be accurate. If accuracy down to the audio-frequency range is required, it is recommended that a resistor be shunted across *C1* so that the two capacitances are in the same ratio as the two resistances. Where the input resistance of the v-t voltmeter varies appreciably with frequency, a shunt resistor sufficiently low to stabilize the tube input resistance must be used.

To insure accuracy, good shielding is required between the multiplier and the v-t voltmeter input. In one commercial multiplier manufactured by the General Radio Company, the multiplier attaches directly to the v-t voltmeter probe head by means of metal flanges which provide effective shielding against stray fields.¹

¹ Sinclair, D. B., "A Voltage Multiplier for use with the V-T Voltmeter at Radio Frequencies," Gen. Radio Experimenter, May 1940.

It might seem that the overall input capacitance could be reduced considerably by eliminating the additional shunt capacitance across the v-t voltmeter. This is not possible, however, since the resistive component of the v-t voltmeter input capacitance, and not the capacitance ratio, $C1/C2$, will then determine voltage reaching the v-t voltmeter input.

Extending the Voltage Range of D-C V-T Voltmeters

The voltage range of d-c v-t voltmeters can be extended by using a high-resistance voltage divider in the input circuit. A suitable arrangement is to use a resistor of the order of a thousand megohms mounted at the probe end of a high-voltage cable. To obtain a multiplying factor of 10, the second resistor which completes the voltage divider (approximately 110 megohms) should be mounted in the instrument proper. The advantage of this arrangement is that the high voltage under measurement is kept away from the operator as well as from the v-t voltmeter. The probe which contains the high-voltage resistor (see p. 140 for a description of a suitable resistor) should always be held so that the complete length of the resistor lies between the hand and the high-voltage point under test.

The high-voltage multipliers required for an extension of the voltage range of d-c v-t voltmeters cannot be obtained to an accuracy greater than about 5 or 10%, except at greatly increased cost. To compensate for this variation, the meter sensitivity can be either increased or decreased by an amount such that the instrument will give a multiplying factor of exactly 10, 30, or whatever the value may be.

Constructional Notes

The construction of v-t voltmeters follows along the same line as the construction of any measuring instrument. The layout should be carefully planned before any constructional work is started. In the r-f section of the unit, the usual practice of short leads and direct bypassing at the tube socket should be followed. As far as is possible, the parts should be arranged so that everything is accessible. The precautions with regard to the circuit design, leakages, adequate low-frequency bypassing, etc., have already been covered.

Chapter X

CALIBRATION AND TESTING OF V-T VOLTMETERS

THE accuracy of a v-t voltmeter depends to a greater or lesser extent upon a relatively large number of variables, including the tube characteristics, operating voltages, resistors and other circuit elements, and the sensitivity of the meter itself. Because of this dependence on a relatively large number of factors, it is necessary to calibrate v-t voltmeters at more or less frequent intervals. In some v-t voltmeter circuits an accuracy can be attained which is independent of variations in the tube characteristics and operating voltages, and in such cases calibration is very seldom required. To go to the other extreme, some sensitive amplifier types of v-t voltmeters require calibration at relatively frequent intervals.

The calibration of a v-t voltmeter consists essentially of interpreting the reading of the indicating meter in terms of the input voltage required to produce the given current reading. This idea was clearly brought out in Fig. 1-3 so that it requires no further discussion here. In the case of directly-calibrated v-t voltmeters, adjustments are usually provided so that the scale can be made to read directly. Where no adjustment is provided, a correction curve can be drawn, or a new calibration curve plotted.

Choice of Standards

In all calibration work some standard of voltage must be used and it is in terms of this standard that the calibration is carried out. In the simplest form of calibration, it is only necessary to place the v-t voltmeter to be calibrated in parallel with the known standard source of voltage and to note the reading of the v-t voltmeter which corresponds to each known value of voltage.

The calibration of the general purpose a-c v-t voltmeter presents relatively little difficulty since its wide frequency range makes it possible to calibrate the instrument at 60 cycles. This frequency calibration will then hold at frequencies up to as high as approximately 100 megacycles, depending upon the design of the v-t voltmeter. Because cali-

bration is possible at 60 cycles, the standard calibrating voltages can be measured by any one of the following meters which are listed in their approximate order of accuracy: (1) Dynamometer, (2) Thermocouple, (3) Moving Iron, and (4) Copper-Oxide Rectifier. The copper-oxide rectifier type of a-c meter should be used only when there is no other available meter since its reliability is usually only about 5%. The other meters range in accuracy from $\frac{1}{4}\%$ to about 2% of full scale.

In the calibration of d-c v-t voltmeters, the problem of standards is very simple indeed since the ordinary moving-coil voltmeter can be relied on to within 2% of full-scale. Where greater accuracy is required, a precision meter can be used which will provide an accuracy as high as $\frac{1}{4}\%$. Ordinarily an accuracy of $\frac{1}{2}\%$ is desirable in the standards which are used to calibrate d-c v-t voltmeters, since a degenerative type d-c v-t voltmeter is stable enough to hold an accurate calibration. In general there is no point in using a standard which is far more accurate than the reliability of the v-t voltmeter which is being calibrated.

General Precautions

There are a number of precautions which should be observed in calibrating v-t voltmeters. To obtain the greatest accuracy, it is desirable to use the standard voltmeter near full scale (where its accuracy is greatest) and to use a voltage-divider arrangement for obtaining fractional voltages. An adequate warm-up period should be allowed for the v-t voltmeter to reach a stable operating temperature before calibration is attempted. D-c v-t voltmeters in particular should never be calibrated when the room temperature is either extremely hot or cold, since the resistors used in high-resistance voltage dividers have a relatively high temperature coefficient. As a safety precaution, where the 60-cycle line is used as a source of calibrating voltage, it is advisable to fuse both sides of the line to prevent possible cross grounds. The waveform of the calibrating voltage should preferably be checked with an oscillograph, since an error will usually result if the calibration is carried out with a distorted wave. *In general, it is desirable to calibrate the v-t voltmeter under the conditions of line voltage, temperature, method of connection, etc., which most closely approximate the actual conditions under which the v-t voltmeter is to be used.*

Use of Tube-Tester Transformer

The ordinary tube-tester transformer which is tapped to provide voltages ranging from about 1 volt to 117 volts is a convenient source of voltage for calibrating v-t voltmeters. Where a separate transformer arranged with a tap switch is not available, a tube tester can

be pressed into service by arranging a plug which can be inserted into any one of the test sockets. Only two connections to the heater terminals need of course be made. In some tube testers, an auto-transformer arrangement is used, so that the line should be fused to prevent possible cross grounds.

Variac or Other Variable Ratio Transformers

An extremely useful device in the calibration of the a-c v-t voltmeter is the variable-ratio transformer of which the Variac is one widely used type. The Variac is essentially a variable-ratio auto-transformer which provides a continuously variable voltage output from 0 to 130 volts when connected to the 115-volt a-c line. The usefulness of such a device in simplifying the calibration of v-t voltmeters is immediately obvious.

To obtain d-c voltages extending up to about 10 or 20 volts, the Variac may be combined with a filament transformer, tube-tester transformer, or other low-voltage transformer. If the low-voltage transformer is connected to the output of the Variac instead of directly to the a-c line, it is possible to obtain a very smooth control of low voltages without any supplementary rheostats to act as a "fine" adjustment. For voltages above about 20 volts, this arrangement is not necessary since the direct output of the Variac provides the desired voltage with a sufficient degree of control.

Set-Up for A-C Calibration

A convenient set-up for calibrating a-c v-t voltmeters is shown in Fig. 10-1. As described in the preceding section, a Variac is employed

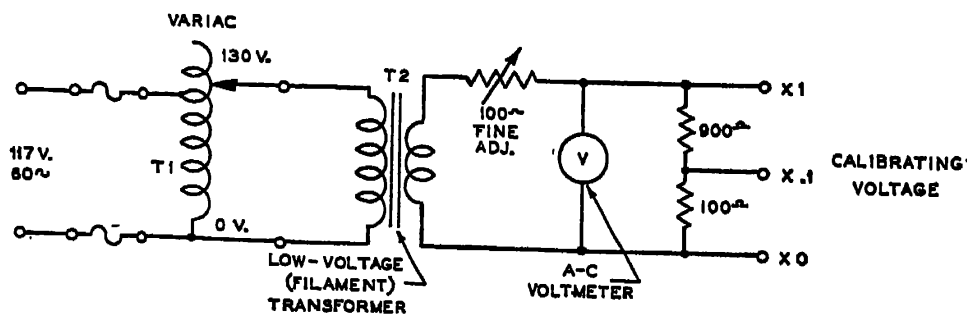

Fig. 10-1. A set-up for calibrating a-c v-t voltmeters. The low-voltage transformer is used only when calibrating the low-voltage ranges.

to feed a low-voltage transformer, the output of which supplies the calibrating voltage. The standard a-c voltmeter used to measure the voltage is placed in shunt with the output of the transformer and a

1-to-10 voltage divider. A "fine" adjustment is included in the circuit (although it is not required when the Variac is used) in order to show how such a rheostat is used in calibrating circuits.

The voltage divider is extremely useful in making it possible to obtain values of voltage smaller than can be read directly by the standard voltmeter against which the calibration is being made. Through the use of such a divider the meter can be read well up on the scale so that good accuracy can be obtained.

For voltages higher than about 10 or 20 volts the low-voltage transformer may be eliminated, and the output of the Variac connected directly to the voltmeter. The usual precaution of fusing the line should be taken.

Use of Decade Voltage Divider

An extremely useful piece of laboratory equipment in the calibration of both a-c and d-c v-t voltmeters is the *decade voltage divider* or potentiometer. In one commercial form of decade voltage divider, any fraction of the input voltage can be obtained from 0.001 to 1.0 in steps of 0.001. For example, if a voltage of 100 volts is applied to the input, any output voltage ranging from 0.001 volt to 100 volts can be obtained in steps of 0.001 volt. The voltage divider being described is manufactured by the General Radio Company. In appearance it is similar to an ordinary three-dial decade resistance box. Actually it consists of two resistance boxes arranged so that resistance is automatically taken from one arm of the potentiometer and added to the other arm, so as to keep the total resistance of the divider constant.

Where a decade voltage divider is used, the accuracy of any of the smaller voltages is as good as the accuracy of the input voltage which can be read near full scale on the standard meter. The error introduced by the voltage divider is negligible since it is standard practice to calibrate the resistors used in the voltage divider within about 0.1%. This is far better than the accuracy with which either the v-t voltmeter or the standard meter can be read.

Extra Condensers for 60-Cycle Calibration

In v-t voltmeters designed especially for r-f measurements, it is sometimes necessary to use additional bypass condensers when carrying out the calibration at 60 cycles. The points at which additional capacity may be required are across the cathode resistor and in the input coupling circuit. The manufacturer's instructions should be referred to when necessary.

Waveform Considerations

Since most a-c v-t voltmeters have a certain amount of waveform error, it is best to carry out the calibration with a pure sine wave. This ordinarily introduces no difficulty since the 60-cycle line is usually pure enough to be satisfactory without any additional filtering.

When a v-t voltmeter which is calibrated to read correctly on a sine wave is used to measure a distorted wave, its reading will in general be subject to error. The exact amount of error depends upon the type of v-t voltmeter and the amount and type of distortion present in the wave. The amount of error to be expected is summarized in the table of Fig. 10-2.¹

At this point the section in Chapter I dealing with waveform considerations should be reviewed. In this connection it should be noted that a peak-reading v-t voltmeter will always read the peak value regardless of whether it is calibrated to read rms values. Thus a peak-reading v-t voltmeter which is calibrated to read rms values really reads peak values multiplied by 0.707. From this it follows that such a v-t voltmeter when used on a complex or distorted wave can readily be used to find the peak value of the wave simply by dividing the "rms" reading by 0.707. Particular emphasis is given to the action of the peak-reading v-t voltmeter which is calibrated in terms of rms values since this type of voltmeter is very widely used commercially.

FIG. 10-2. EFFECT OF HARMONICS ON READINGS OF V-T VOLTMETERS

| | <i>Full-Wave Square Law</i> | <i>Half-Wave Square Law</i> | <i>Linear</i> | <i>Peak</i> |
|--------------------------------|---------------------------------|---------------------------------|---------------|--------------------|
| <i>Turnover</i> | No Change | Reading Changes | No Change | Reading Changes |
| <i>50% Second Harmonic</i> | 12% | -6 to +27% | 0 to 10% | -25 to +50% |
| <i>50% Third Harmonic</i> | 12% | 12% | -10 to +16% | +8 to +50% |

Turnover—In connection with waveform error, the manner in which a distorted wave is connected to the input of the v-t voltmeter will often affect the reading. For example if an unsymmetrical wave, such as is shown in Fig. 1-6, is applied to a peak-reading v-t voltmeter, readings of 100 volts or 60 volts will be obtained depending upon the polarity of the connection. This effect is known as *turnover*, and the

¹ Wolff, I., "A-C Measuring Instruments as Discriminators against Harmonics," Proc. I.R.E., April 1931, p. 647.

manner in which the various types of v-t voltmeters are subject to turnover error is indicated in Fig. 10-2. In particular it will be noted that the full-wave square law and the average-reading (linear) types of v-t voltmeters are not subject to turnover error; the same reading will be obtained regardless of whether or not the input connections are reversed. In those cases where turnover is indicated (because there is a difference in the two readings when the input connections are reversed), it is generally true that the average of the two readings is a closer approach to the desired reading than either of the separate values.

It is very important to make certain that what appears to be turnover is really turnover and not stray pickup or leakage which may result when one side of the voltage being measured is grounded. In such cases a discrepancy between the two readings may occur because of stray pick-up, leakage, and cross ground effects.

Consistency Check

In calibrating multi-range v-t voltmeters, it is desirable to check the various ranges against each other to see that they are consistent. For example, a voltage which reads 10 volts (full scale) when the range switch is in the 10-volt position, should also read 10 volts on the 30-volt scale when the range switch is in the 30-volt position. Because readings taken at a fraction of full scale are not as accurate as readings near full scale, perfect agreement cannot be expected.

Use of Outer Linear Scale

The general purpose v-t voltmeter usually has a considerable number of separate scales, often as many as six or more. As a result, the relative length of the inner scale is considerably less than the length of the outer scale. This makes it difficult to read accurately voltages on the shorter inner scales. Where the greatest accuracy is desired, this shortcoming can be overcome by using the outer scale as an arbitrary scale in conjunction with a calibration curve specially made for the purpose. Usually this outer scale is linear or very closely linear so that it provides a convenient reference scale. In this way the effective length of the inner scales can be greatly increased, although there is the disadvantage that a calibration curve must be used. Since the direct-reading inner scales are sufficiently accurate for practically all measurements, the calibration curve need be used only when the greatest accuracy is required.

Correction Curve for Slide-Back V-T Voltmeters

As pointed out previously, slide-back v-t voltmeters are relatively inaccurate on a-c voltages below about 10 volts because of the rectifica-

tion error. This applies to both the diode slide-back types, as well as to the triode types. For reasonably accurate work, it is desirable to make a correction curve or separate calibration curve for the low-voltage ranges so that the slide-back voltage may be corrected to determine the true a-c peak voltage.

This calibration or correction curve can be made by applying known values of voltage between about 0.1 volt and 10 volts and noting the value of slide-back voltage which gives the reference value of plate current. A curve can then be plotted which shows the true value of peak voltage in terms of the indicated d-c slide-back voltage. Alternatively, a correction curve may be plotted which shows the amount which must be added to the slide-back voltage in order to obtain the true peak voltage. To avoid error, the same reference value of plate current which is employed for making the calibration must be used whenever the slide-back v-t voltmeter is subsequently employed.

Calibration of V-T Voltmeters at Ultra-High Frequencies

The calibration of v-t voltmeters at frequencies above about 30 megacycles presents a great many difficulties. At these frequencies, the ordinary standards which are adequate at low frequencies are entirely unsatisfactory. A description of the apparatus and methods for ultra-high frequency calibration of v-t voltmeters is beyond the scope of this book.¹

Measuring the Input Impedance of A-C V-T Voltmeters

The input impedance of a-c v-t voltmeters may be measured by any of the methods which are used for measuring impedance at radio frequencies. It is convenient to consider the input impedance as consisting of a condenser which is shunted by a resistor, the former representing the input capacitance of the v-t voltmeter, while the latter represents the input resistance or loading effect.

The capacitance of the v-t voltmeter may conveniently be measured at low frequencies using the standard substitution method. Care should be taken to see that the length of the leads to the input terminals are not measured as being part of the input capacitance.

Measuring the loading effect of the v-t voltmeter is more difficult, since the input resistance varies very widely with the frequency, so that the measurement must be carried out at radio frequencies. A convenient method for measuring the input resistance is to connect the v-t voltmeter across a high-Q tuned circuit. If the losses introduced by the v-t voltmeter across the tuned circuit are high in comparison with the losses

¹Nergaard, L. S., "A Survey of Ultra-High-Frequency Measurements," RCA Review, Oct. 1938, p. 156.

of the tuned circuit itself, the v-t voltmeter resistance can be determined by using the capacitance or frequency variation methods for measuring resistance. In both of these methods the unknown resistance is determined by the effect of the resistance on the sharpness of the selectivity curve, using the v-t voltmeter which is being measured to provide the relative output readings (see p. 160). Where the v-t voltmeter losses are very small, it is necessary to have two identical v-t voltmeters in order to determine the exact losses. The procedure is to shunt the second v-t voltmeter across the same tuned circuit and to note the additional effect on the selectivity curve. The input resistance of the v-t voltmeter may then be determined with good accuracy. The second v-t voltmeter need consist only of the input tube and need not have a d-c amplifier or meter.

The manner in which the input resistance of v-t voltmeters drops as the frequency is increased has been shown in Fig. 9-1. Note that the input resistance is considerably higher for the acorn tube than for the conventional receiving tube.

The input resistance of a-c v-t voltmeters at 60-cycles may be determined readily by noting the value of series resistance required to drop the full-scale deflection to half-scale deflection. The value of resistance required is equal to the input resistance of the v-t voltmeter. Metallized resistors are satisfactory for this measurement because of their lower shunt capacitance and because high accuracy is not required.

V-T Voltmeter As a Comparison Voltmeter

In sensitive v-t voltmeters where it is not possible to make a direct calibration which will be accurate over an appreciable period of time, it is common practice to use the v-t voltmeter in conjunction with a standard source of voltage, as is shown in Fig. 10-3. The procedure for

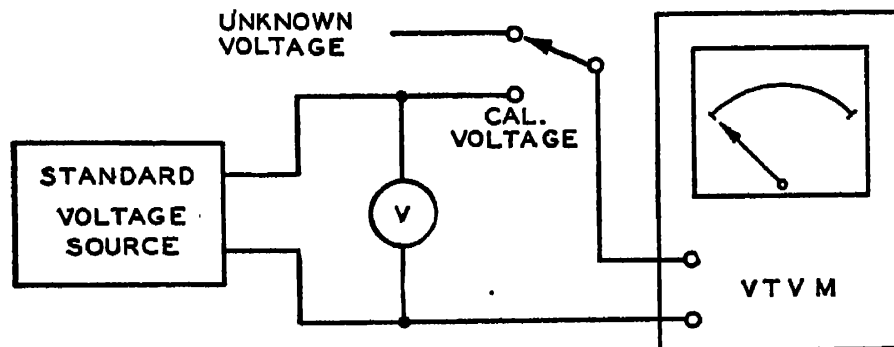

Fig. 10-3. Highly accurate voltage measurements can be made by noting the standard voltage required to obtain the same deflection on the v-t voltmeter.

measuring an unknown voltage is first to connect the v-t voltmeter to the unknown voltage and to adjust the v-t voltmeter sensitivity so that

a full-scale reading is obtained. The standard source of voltage, which may be either a standard signal generator or a potentiometer set-up, is then connected to the v-t voltmeter, and the standard voltage adjusted to obtain the same reading on the v-t voltmeter. It follows that the unknown voltage is then equal to the standard voltage. No adjustments should of course be changed on the v-t voltmeter, and the frequency of the standard voltage source should preferably be the same as the frequency of the unknown voltage, especially where the v-t voltmeter has a non-uniform frequency response. This type of set-up, while it does not have the convenience of a directly calibrated v-t voltmeter, has the advantage of combining the high input resistance characteristic of the v-t voltmeter with the high order of accuracy made possible by using either a low-frequency source of comparison voltage or a standard signal generator.

Use of Log-Log Paper for Square-Law V-T Voltmeters

The calibration of square-law v-t voltmeters can be simplified by plotting the calibration on log-log graph paper instead of on the conventional linear graph paper. Because of the square-law relationship

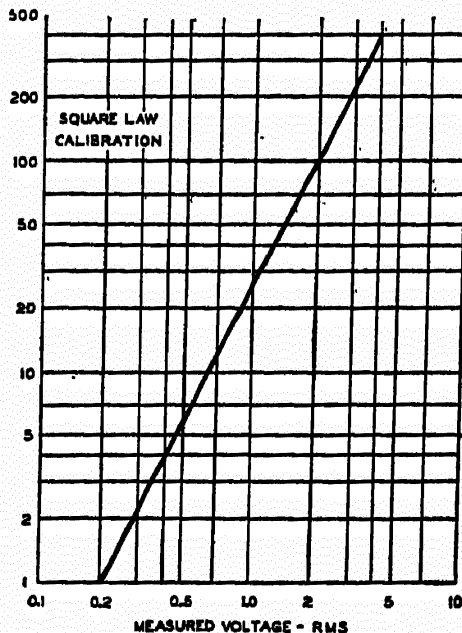

Fig. 10-4. The calibration of square-law v-t voltmeters can be simplified by using log-log graph paper. Compare this curve with the equivalent curve shown in Fig. 3-7b.

between the plate current and the input voltage, the calibration curve plotted on log-log paper will be a straight line over the portion of the calibration which shows a square-law response. The calibration curve of Fig. 3-7b plotted on log-log paper is shown in Fig. 10-4. Note that the calibration procedure is simplified considerably since only relatively few points are required to determine the straight line.

Checking a Decibel or Logarithmic Calibration

In the calibration of decibel or logarithmic v-t voltmeters, it is frequently desirable to check the accuracy of the scale calibration. This can readily be done without any special equipment since v-t voltmeters of this type are usually provided with a calibrated input attenuator which covers a wider range than the direct-reading decibel scale.

To check the accuracy of the scale calibration, the input attenuator (use an external attenuator if the instrument does not have one) can be adjusted to the middle of its range, and a signal applied so that a mid-scale reading is obtained. The input attenuator can then be varied on both sides of the initial setting, and the meter reading noted to see whether it agrees with the attenuator reading. Thus if the attenuator is changed by 6 db, the meter reading should also change 6 db. In commercial instruments, adjustments are usually provided for making the scale track accurately. The manufacturer's instructions should be followed in making these adjustments, since the procedure varies depending upon the design of the circuit.

Calibration of D-C V-T Voltmeter

The calibration of d-c v-t voltmeters is considerably simpler than that of a-c v-t voltmeters because frequency response is not a factor. Essentially, the calibration procedure is to place the v-t voltmeter in parallel with a good d-c voltmeter which is known to be accurate to within $\frac{1}{2}$ to 1%, depending upon the desired accuracy. Various values of d-c voltage are then applied, and the reading of the v-t voltmeter compared with the reading of the standard voltmeter at a sufficient number of points on each range. Usually d-c v-t voltmeters are provided with a calibration adjustment for each range. This adjustment should be set so that the v-t voltmeter reading is accurate at full-scale deflection. If a decade voltage divider or calibrated potentiometer is available, the calibration procedure can be simplified considerably as previously explained. In this case the input voltage to the decade voltage divider is standardized, and then any desired value of output voltage can be obtained.

Sensitive d-c v-t voltmeters which do not have sufficient accuracy to hold a calibration over a long period of time may be used in conjunction with a standard source of d-c voltage to make possible the accurate measurement of small voltages, while retaining the high input resistance characteristic of the v-t voltmeter. The decade voltage divider is extremely useful for this application.

Measuring Grid Current and Input Resistance of D-C V-T Voltmeters and V-T Ohmmeters

The importance of low grid current and high input resistance in d-c v-t voltmeters has already been covered. The following procedure may be used to measure the grid current: First insert a high value of resistance in the grid circuit, of the order of 100 megohms or higher, and set the zero adjustment so that a zero reading is obtained on the most sensitive range. The control grid should then be shorted to ground, and the change in the zero reading noted. The grid current can then be computed by dividing (1) the voltage reading corresponding to the change by (2) the resistance inserted in the grid circuit. The grid current is of course not constant, but depends upon the value of resistance in the grid circuit. However, the above method can be used to check the grid current for any value of grid resistance which is large enough to cause a change in the voltage reading of the instrument on the most sensitive range.

In connection with the above measurement, any leakage currents which may exist in the input circuit will cause a change in the reading which is not due to grid current. As previously mentioned, these leakage currents can be completely eliminated by proper design and layout. An important precaution to note in making the above measurement is that the resistor through which the grid circuit is completed must be mounted close to the control grid in order to minimize leakage and stray a-c pickup in the grid circuit.

The input resistance of d-c v-t voltmeters can readily be measured by inserting a resistance in series with a source of d-c voltage which is sufficient to drop the voltage reading to one-half. The input resistance will then be equal to the above required value of series resistance. The input resistance varies with the value of applied voltage, so that the measurement should be made at those voltages which are of interest.

A rapid check for the presence of grid current in v-t ohmmeters can be made by rotating the range switch from the low-resistance ranges to the highest-resistance range. If there is negligible grid current, no change in the full-scale position of the meter pointer will be observed, while the presence of grid current will be indicated by a decrease in the deflection.

Chapter XI

APPLICATIONS OF V-T VOLTMETERS

THE applications of v-t voltmeters are so numerous and varied that without exaggeration they can be said to cover the entire field of radio measurements. This is to be expected since voltage is one of the fundamental electrical quantities, and the v-t voltmeter provides virtually the only means for measuring voltage with a reasonably small reaction on the circuit under test. In view of the practically unlimited number of applications, we must consider only those in this chapter that are fundamental in character.

The various types of v-t voltmeters which have been described provide for every type of voltage measurement which need be made. Thus v-t voltmeters are available for measuring d-c voltages; for measuring the peak, average, and rms values of a-c voltages; and the peak and trough values of pulsating voltages. In addition, amplifier type v-t voltmeters make it possible to measure very small voltages such as those encountered in the various stages of radio receivers.

Amplifier Stage Measurements

The v-t voltmeter is useful in checking the operation of a single amplifier or oscillator stage. To measure the gain of an amplifier stage, a source of voltage of approximately 1 volt should be applied to the control grid. The gain of the stage can then be determined by measuring the input and output voltages by means of a v-t voltmeter. When this measurement is made at radio frequencies, the high-voltage output of a signal generator (providing approximately 1 volt) can be used to feed the input of the stage. The probe type of v-t voltmeter is almost indispensable for making measurements of this type at radio frequencies.

Peak and Trough Voltage Measurement—In checking the operation of amplifier and oscillator stages, the use of a peak and trough v-t voltmeter (see Chapter II) provides a convenient method for determining the maximum and minimum voltages on the grid and plate. For example in Class B amplifier circuits it is necessary that the plate voltage should not drop below the grid voltage during the positive peak of the

grid excitation. By using a *peak v-t voltmeter* to measure the positive grid excitation, and a *trough v-t voltmeter* to measure the lowest voltage to which the plate drops, the optimum operating conditions can be established. These v-t voltmeters can be used in a similar way in the design of oscillator circuits.

Signal Tracing—Checking Amplifier and Receiver Operation

In Chapter VII a number of sensitive audio-frequency v-t voltmeters which permit measurements of audio-frequency voltages from a millivolt to several hundred volts were described, while in Chapter VI the tuned amplifier type of v-t voltmeter was described. Using both of these v-t voltmeters, it is possible to check the operation of an amplifier or receiver by connecting a source of voltage to the input and measuring the signal voltage developed at every point of interest in the amplifier. Commercial signal-tracing instruments have been developed which contain two v-t voltmeters of the type described, one for measuring audio-frequency signal voltages and one for measuring radio-frequency and intermediate-frequency voltages. With such an instrument it is possible to measure the signal voltage at the input and output of each stage in a receiver and in this way to check gain, hum, distortion, and to localize any defective condition which may be present. In servicing intermittent receivers in particular, these v-t voltmeters or signal-tracing instruments have proved to be extremely valuable since they permit a continuous monitoring of the signal voltage at key points in the receiver.

A complete description of the methods of signal tracing would take up far more space than is available here. A further discussion of this subject can be found in "Servicing by Signal Tracing" by John F. Rider.

Measuring Transformer Turn Ratio

The v-t voltmeter provides a rapid method for measuring the turn ratios of all types of audio transformers. The procedure for this measurement is to apply a 60-cycle or 400-cycle voltage to the primary winding and to measure the voltages across the primary and secondary. The ratio between the secondary and primary voltages, both of which can be measured with the v-t voltmeter, is then equal to the turn ratio. Although it is usually more convenient to make this measurement at 60 cycles, greater accuracy will be secured if 400 cycles is used since the voltage drop across the resistance of the primary will then be negligible in comparison with the inductive voltage drop across the primary. If the measurement is made at a high audio frequency, an error will be introduced because of a resonance effect due to the capacitance of the secondary winding.

Power-Supply Measurements

The various types of v-t voltmeters can be used to advantage in power-supply measurements. Thus the peak v-t voltmeter can be used to measure the peak voltage which is applied to the first filter condenser. The conventional a-c v-t voltmeter can be used to measure the ripple voltage at any point in the filter circuit. For this application a blocking condenser having low d-c leakage should be used. Where the filter output is exceptionally well filtered, a more accurate indication of the hum voltage can be secured by using the amplifier type of audio-frequency v-t voltmeter described in Chapter VII. The d-c v-t voltmeter can of course be used to measure any of the d-c voltages, although a conventional voltmeter is usually satisfactory because the loading is of no consequence.

Low-Frequency Impedance Measurements

A simple circuit for the measurement of impedance at low frequencies is shown in Fig. 11-1. In this arrangement the impedance Z_x to be

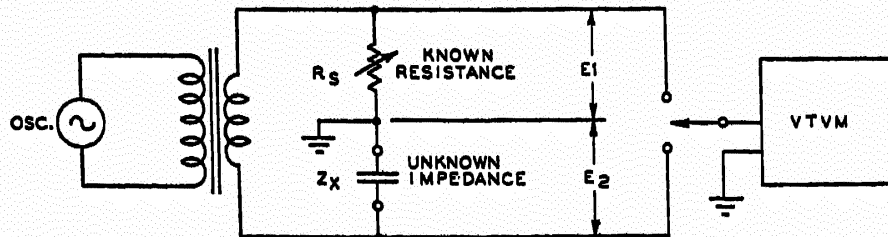

Fig. 11-1. The unknown impedance Z_x is measured by comparing the voltage drop across Z_x with the voltage drop across the standard resistor R_s .

measured is placed in series with a variable resistance R_S and connected to a source of low-frequency voltage. The impedance to be measured may consist of a condenser, a choke or any combination of resistance, capacitance and inductance. When the resistor R_S is adjusted so that the voltage E_1 across R_S is equal to the voltage E_2 across the unknown impedance, it follows that the unknown impedance is equal to the value of R_S . R_S can be measured readily with a good ohmmeter or bridge, if a direct-reading resistance box is not available. For any other relation between the voltages E_1 and E_2 , the unknown impedance can be found from the following equation.

$$Z_x = R_S \frac{E_2}{E_1}$$

Because of the effect of stray circuit capacitance, including shunt capacitance across R_g , this method of measuring impedance is most suitable for power and audio frequencies. Where the impedances involved are relatively low, the method will give accurate results up to low radio frequencies, although the circuits shown in the following section are more suitable for use at radio frequencies. A transformer, delivering approximately 1 watt, should be used between the oscillator and the impedance-measuring circuit in order to secure an ungrounded voltage source.

Measuring Inductance, Capacitance, and Resistance

Two basic circuits for the measurement of inductance, capacitance, resistance, and Q are shown in Fig. 11-2. Basically measurements are made with these circuits by making the coil, condenser or resistor to be measured a part of a tuned circuit, and determining the unknown quan-

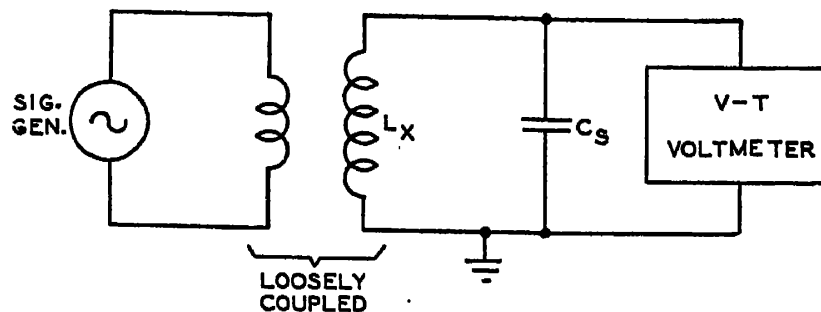

Fig. 11-2a. By using the v-t voltmeter to determine the resonant frequency and selectivity of the tuned circuit, it is possible to measure inductance, capacitance, and resistance.

tity in terms of the behavior of the tuned circuit when a voltage is applied to the tuned circuit.¹ In the circuit shown at (a), the r-f voltage is induced in the tuned circuit by using a small coil loosely coupled to the tuned circuit. In the set-up at (b), the r-f voltage is fed into the tuned circuit by placing it in the plate of an r-f pentode. The latter circuit has the advantage that no special coupling coil is required. The shunting effect of the tube can ordinarily be neglected, although for high-frequency measurements it is recommended that an acorn type tube be used.

For the measurement of inductance, the usual procedure is to employ a standard condenser in parallel with the unknown coil. With the standard condenser set at some convenient value such that the total

¹ For further data on the use of the v-t voltmeter for such measurements, see Terman, F. E., "Measurements in Radio Engineering," McGraw-Hill Book Co.

capacitance across the coil is equal to several hundred micromicrofarads, the signal-generator frequency should be varied until the v-t voltmeter indicates resonance by a maximum output indication. For this condition the inductance of the coil can be found by the following equation:

$$L_x = \frac{25.330}{f^2 C_s}$$

where L_x is in microhenrys, f is in megacycles, and C_s in micromicrofarads.

For the measurement of capacitance, the same general procedure is followed with the exception that a standard coil having a known value of inductance is used. This coil is placed in shunt with the unknown condenser and the frequency varied until the v-t voltmeter shows a maximum output indication, indicating resonance. For this resonant condition, the capacitance of the condenser can be obtained from the following equation:

$$C_x = \frac{25.330}{f^2 L_s}$$

The r-f resistance or Q of a tuned circuit can also be determined with this same circuit. One method for making this measurement is the so-

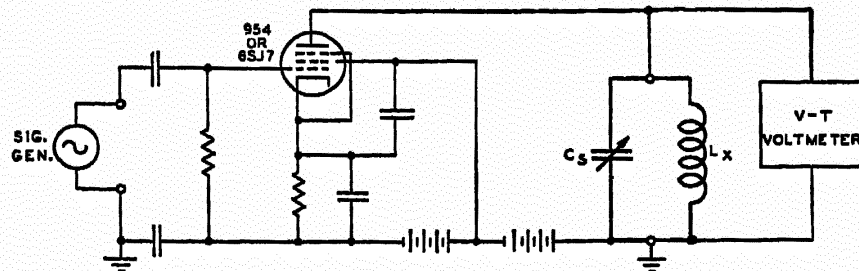

Fig. 11-2b. An arrangement for measuring the characteristics of tuned circuits in which the voltage is coupled into the tuned circuit by placing it in the plate circuit of an r-f pentode.

called *frequency-variation* method. As the name implies, the procedure is to determine the selectivity of the tuned circuit by varying the frequency of the input voltage on either side of resonance, using the v-t voltmeter to measure the voltage across the tuned circuit. The sharpness of resonance is then an indication of the resistance of the tuned circuit, and by means of calculations which are beyond the scope of this book, it is possible to determine the resistance of the tuned circuit.¹

With suitable modifications, this circuit can be used to measure r-f resistance over a wide range. In general, low values of resistance are

¹ See footnote on preceding page.

measured by inserting them in series with the tuned circuit so that they may be considered as part of the coil resistance, while relatively high values of resistance are measured by shunting them across the tuned circuit and noting the effect on the selectivity of the tuned circuit.

Other methods for making similar measurements are described in the standard engineering texts on radio-frequency measurements. A widely-used method employing the v-t voltmeter is the *capacitance-variation* method, in which the selectivity curve resulting from the capacitance variation of a standard condenser is determined.

In all of these circuits employing v-t voltmeters, it is essential that the losses of the v-t voltmeter be small in comparison with the losses of the tuned circuit under measurement. Preferably the v-t voltmeter should be of the probe type employing an acorn tube to minimize losses in the v-t voltmeter itself. For accurate measurements, an allowance must be made for the input resistance of the v-t voltmeter.

V-T Voltmeter for Measuring Alternating Currents

The a-c v-t voltmeter can be used for measuring alternating currents by providing a suitable shunt across the input of the instrument. In general two types of shunts are used for this purpose. Where a wide frequency range must be covered, the resistive type of shunt should be employed. Where the measurements are to be carried out at a single frequency, as for example in working with resonant circuits, it is preferable to use a condenser as a shunt in order to reduce the losses introduced into the tuned circuit.

The v-t voltmeter used in this way as a current meter has the advantage that greater sensitivity can be secured and that less power is taken from the circuit under test. The sensitive audio-frequency v-t voltmeters described in Chapter VII can be readily adapted to the measurement of very small a-f currents with a minimum of power consumption from the circuit under test and with a minimum of voltage drop across the current meter.

Where the capacitive type of shunt is used, there will be an appreciable waveform error in measuring complex or distorted currents since the condenser shunt offers a smaller reactance to the high-frequency components of the current wave.¹

V-T Voltmeters in Modulation Indicators

The modulation indicator illustrates an application of v-t voltmeters in which three types of v-t voltmeters are used in one instrument. In measuring the modulation percentage of a modulated wave, it is neces-

¹ Sinclair, D. B., "The Type 726-A V-T Voltmeter as an R-F Ammeter," Gen. Radio Experimenter, Aug.-Sept. 1938.

sary to know the average amplitude of the modulated wave (the carrier), the peak amplitude, and the trough amplitude. To determine these values, it is customary to use an *average-reading v-t voltmeter* to measure the carrier, a *peak v-t voltmeter* to measure the positive peak modulation, and a *trough v-t voltmeter* to measure the negative peak modulation. In one widely used arrangement, the r-f input to the modulation indicator is first adjusted so that the carrier v-t voltmeter indicates some fixed reference value of input voltage. A positive peak v-t voltmeter can then be calibrated directly in terms of the positive percentage modulation, while a trough v-t voltmeter can be calibrated directly in terms of the negative percentage modulation. A phase-reverser stage may be used so that the same peak v-t voltmeter will also indicate the negative percentage modulation.¹

V-T Voltmeters in Wave Analyzers

The v-t voltmeter is the basis of several types of harmonic or wave analyzers which are used to determine the harmonic content of complex waves. These instruments are extremely useful in many applications, particularly in analyzing the distortion of audio amplifiers.

In one type of harmonic analyzer, the voltage wave to be analyzed is fed to the input of a square-law v-t voltmeter. At the same time a search or exploring frequency is fed into the input in series with the unknown voltage. When the search frequency is adjusted to within a few cycles of any of the harmonics, a beat frequency will be obtained, and the pointer of the v-t voltmeter will oscillate slowly about the mean reading. From the amplitude of this swing, it is possible to determine the amplitude of the harmonic component.²

In a more recently developed wave analyzer a highly selective calibrated superheterodyne amplifier type of v-t voltmeter is employed. In one commercial instrument, a superheterodyne amplifier having an intermediate frequency of 50 kc is used and a selectivity within a few cycles obtained by using a crystal filter in the i-f amplifier. By tuning the amplifier to each of the harmonics in turn, it is possible to determine the harmonic content of the wave.³

D-C Voltage, Current, and Resistance Measurements

The trend toward the use of high-resistance circuits makes the d-c v-t voltmeter extremely useful and accounts for its present popularity. In

¹ Arguimbau, L. B., "Monitoring of Broadcast Stations," Gen. Radio Experimenter, Feb. 1935.

² Suits, C. G., "A Thermionic Method for Analysis of Electrical Waves," Proc. I. R. E., Jan. 1930, p. 178.

³ Arguimbau, L. B., "Wave Analysis," Gen. Radio Experimenter, June-July 1933; Dec. 1938.

such circuits the d-c v-t voltmeter makes possible measurement of the true operating and control voltages with a minimum of reaction on the circuit under test. Typical applications of the d-c v-t voltmeter include the measurement of tube electrode voltages where these are fed through high resistances, the measurement of control voltages in automatic volume control, automatic frequency control, automatic volume expansion and contraction circuits, etc. In obtaining discriminator characteristics and making adjustments on frequency-modulation receivers, the d-c v-t voltmeter is particularly useful. In fields where minute currents and voltages must be measured, such as in electronic and biological research, the d-c v-t voltmeter has supplemented and in many cases entirely replaced, the sensitive suspension type of galvanometer.

The application of the d-c v-t voltmeter to the design of d-c v-t ohmmeters has already been covered in Chapter VIII. These instruments are extremely sensitive, and suitable for the measurement of almost any value of resistance ranging from a fraction of an ohm to the highest resistances encountered.

COMMERCIAL V-T VOLTMETERS

SLIDE-BACK VACUUM-TUBE VOLTMETER

Ranges 0-25 V. and 0-250 V.

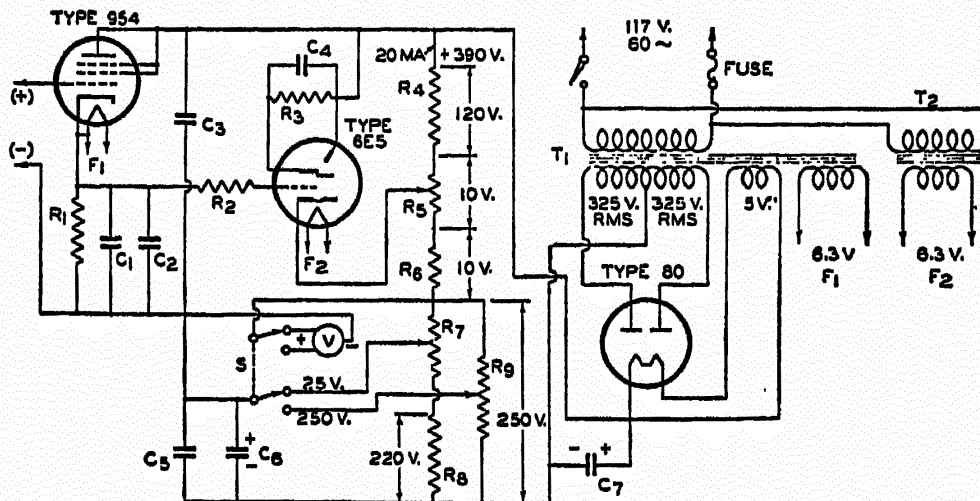

$C_1 = 4 \mu\text{f}$ paper, 400 v
(low-leakage)
 $C_2, C_3, C_4 = 0.01 \mu\text{f}$ mica
 $C_5 = 0.25 \mu\text{f}$ paper, 200 v
 $C_6 = 8 \mu\text{f}$ electrolytic, 350 v.
 $C_7 = 30 \mu\text{f}$ electrolytic, 450 v
 $R_1 = 2$ megohms, 0.5 watt
 $R_2 = 200000$ ohms, 0.5 watt
 $R_3 = 500000$ ohms, 0.5 watt

$R_4 = 6000$ ohms, 5 watts
 $R_5 = 500$ ohm wire-wound linear potentiometer, 2 watts
 $R_6 = 500$ ohms, 1 watt
 $R_7 = 3000$ ohm wire-wound linear potentiometer, 2 watts
 $R_8 = 22000$ ohms, 5 watts
 $R_9 = 25000$ ohm wire-wound linear potentiometer, 4 watts

S = Ganged D.P.D.T. switch
V = 1000-ohms-per-volt volt meter, 0-25 v. and 0-250 v. scales
 T_1 = Midget power transformer
 T_2 = Midget filament transformer

NOTE: If the 954 is mounted at the end of a shielded "goose-neck" probe, C_1 can be mounted on the main chassis. R_1 , C_2 , and C_3 should be mounted close to the 954 socket. For "zero" adjustment of the 6E5, short the 954 input terminals, set R_7 or R_9 so that "V" reads zero volts, and adjust R_8 until the 6E5 "eye" is just closed. The d-c or a-c voltage to be measured will cause the eye to reopen. Then adjust R_7 or R_9 until the eye is just closed again. "V" will then read the d-c or peak a-c value of the input voltage. The V-T voltmeter requires calibration only for very low values of a-c input voltage.

Courtesy RCA Manufacturing Co., Inc.

A rectifier type v-t voltmeter in which the rectified voltage developed at the cathode of the 954 acorn tube is measured by a slide-back method. The 6E5 electron ray tube is used as the balance indicator.

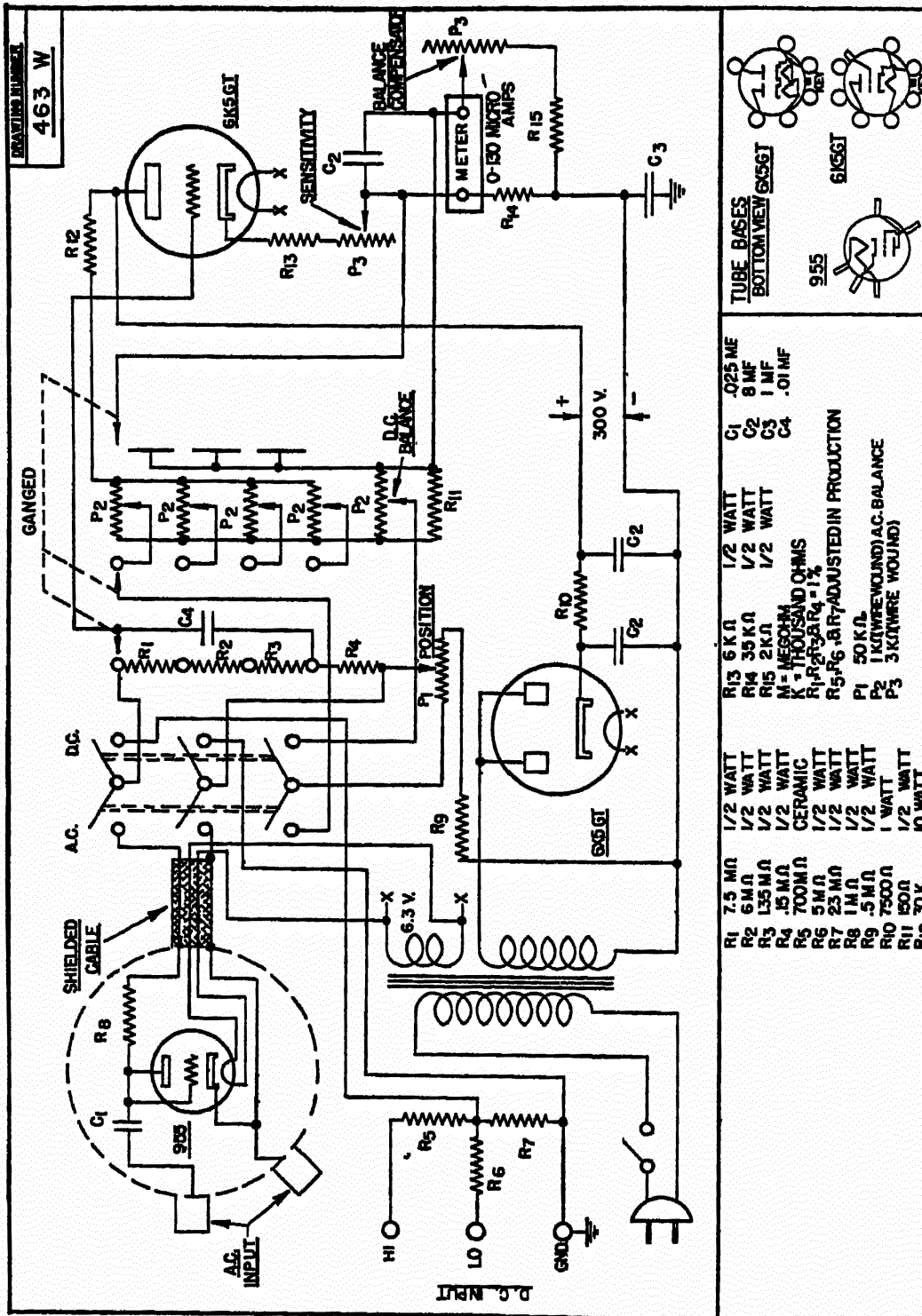

Courtesy Hickok Electrical Instrument Co.

Schematic of the Hickok Model 110 v-t voltmeter.

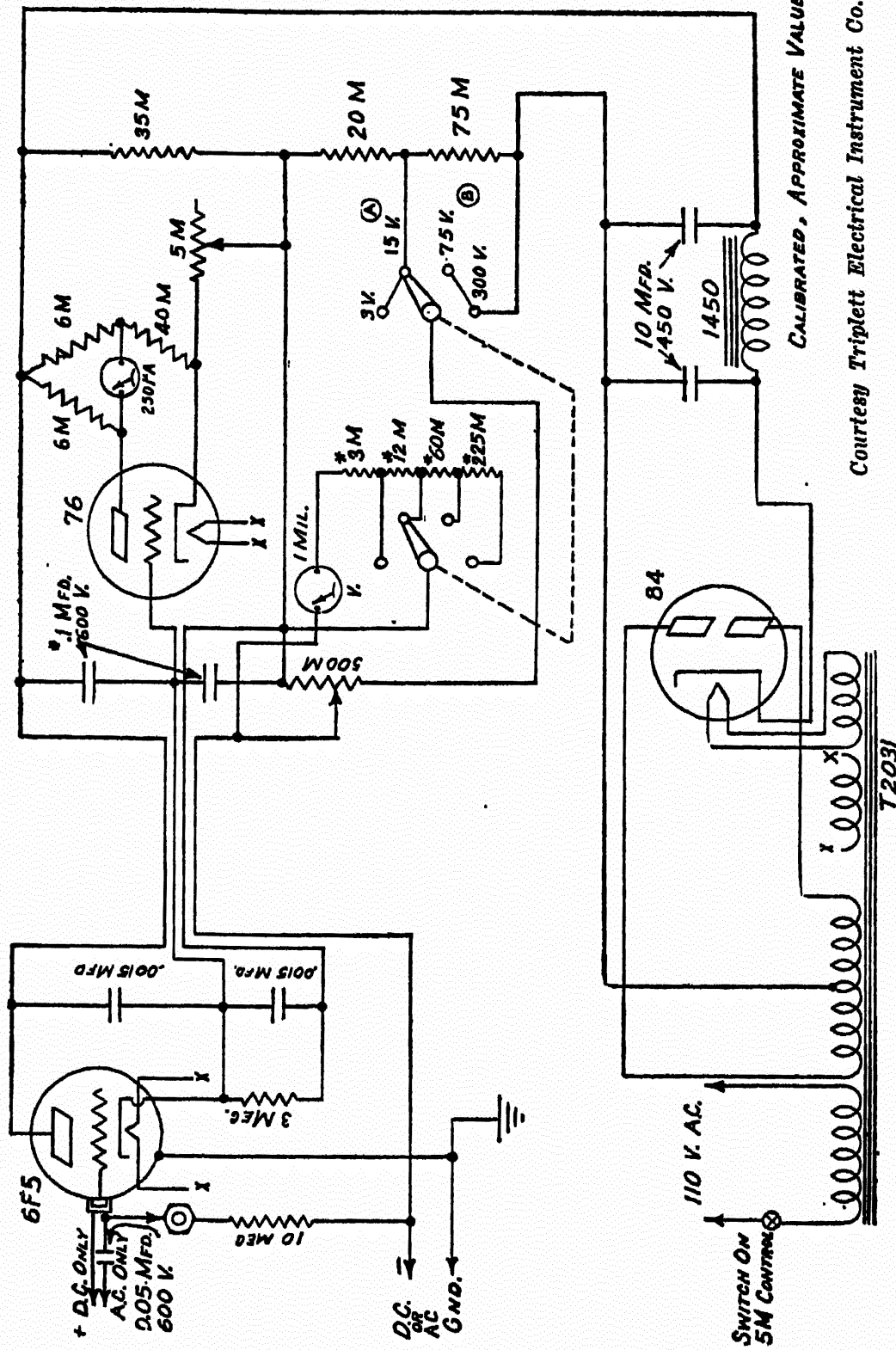

Schematic of the Triplet Model 1252 v-t voltmeter.

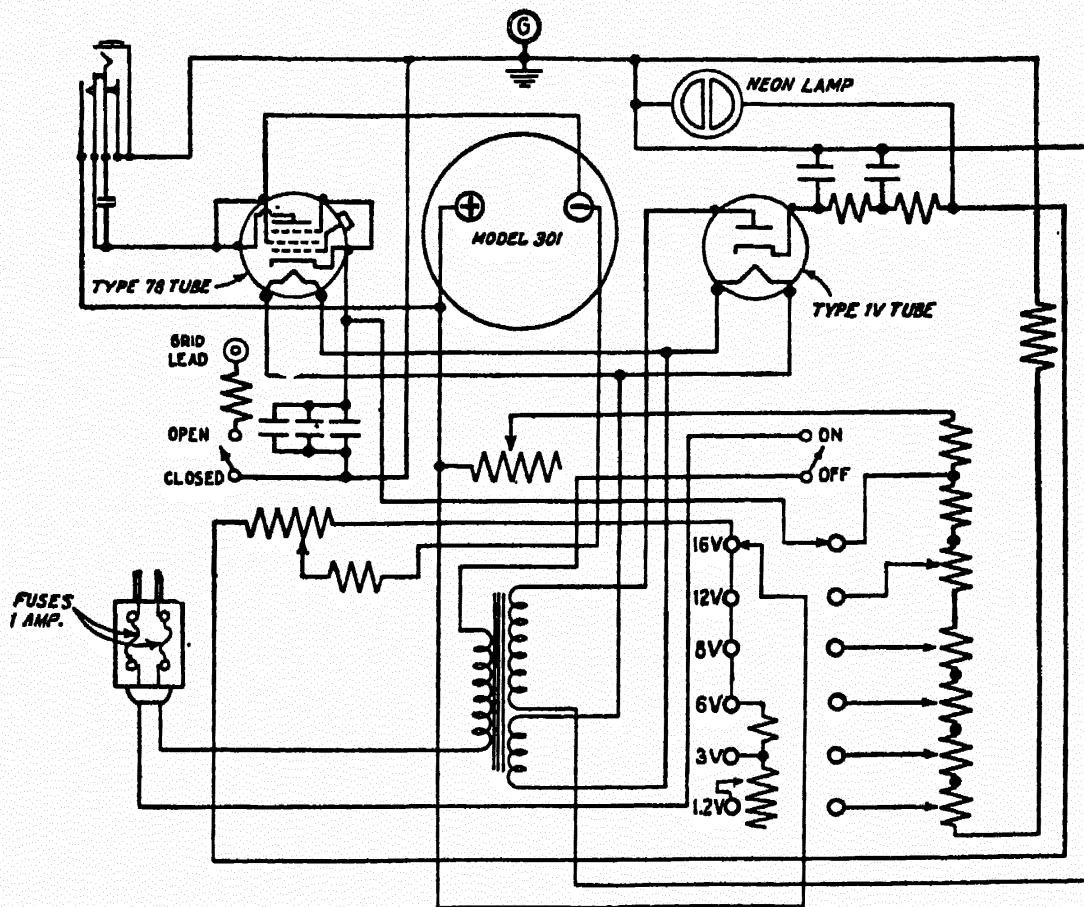

Courtesy Weston Electrical Instrument Corp.

Schematic of the Weston Model 669 v-t voltmeter.

BIBLIOGRAPHY

- Aiken, C. B., Theory of the Diode Voltmeter, Proc. I.R.E., Vol. 26, No. 7, p. 859, July, 1938.
- Aiken, C. B., and Birdsall, L. C., Sharp Cutoff in Vacuum Tubes, with Applications to the Slide-Back Voltmeter, Electrical Engineering, Vol. 57, No. 4, p. 171, April, 1938.
- Andrewes, H., and Lowe, F. A., Probe Valve Voltmeter, Wireless World, Vol. 46, No. 3, p. 83, Jan., 1940.
- Albin, F. G., A Linear Decibel-Scale Volume Indicator, Jour. Soc. Mot. Pic. Eng., Vol. 29, No. 5, p. 489, Nov., 1937.
- Anonymous, Peak Voltages, Aerovox Research Worker, Vol. 8, No. 6, June, 1936.
- Anonymous, An Ideal Valve Voltmeter, Wireless World, Vol. 41, No. 3, p. 62, July 16, 1937.
- Anonymous, Vacuum-Tube Voltmeters, Aerovox Research Worker, Vol. 10, No. 8, Aug., 1938, Vol. 10, No. 9, Sept., 1938.
- Anonymous, Valve Voltmeters in Theory and Practical Use, Electronics, Television, S-W World, Vol. 12, No. 140, p. 594, Oct., 1939.
- Ardenne, M. von, A Sensitive Valve Voltmeter Without "Backing Off," Wireless Eng., Vol. 6, No. 75, p. 669, Dec., 1929.
- Ardenne, M. von, Voltage Measurements at Very High Frequencies, Wireless Eng. and Experimental Wireless, Vol. 14, No. 164, p. 248, May, 1937.
- Arguimbau, L. B., Wave Analysis, General Radio Experimenter, Vol. 8, No. 1-2, p. 12, June-July, 1933.
- Arguimbau, L. B., Monitoring of Broadcast Stations, General Radio Experimenter, Vol. 9, No. 9, Feb., 1935.
- Arguimbau, L. B., The New Wave Analyzer, General Radio Experimenter, Vol. 13, No. 7, Dec., 1938.
- Bacon, W., Peak Voltage Measurements, Electronics, Television, S-W World, Vol. 13, No. 149, p. 323, July, 1940.
- Ballantine, S., Variable- μ tetrodes in logarithmic recording, Electronics, Vol. 2, No. 1, p. 472, Jan., 1931.
- Ballantine, S., Electronic Voltmeter Using Feedback, Electronics, p. 33, Sept., 1938.
- Barber, A. W., A Diode-Triode Peak Voltmeter, Electronics, Vol. 7, No. 10, p. 322, Oct., 1934.
- Best, F. H., Decibel Meters, Bell Lab. Rec., Vol. 15, No. 5, p. 167, Jan., 1937.
- Boyle, H. G., A Highly Flexible V.T. Voltmeter, Electronics, Vol. IX, p. 32, Aug., 1936.
- Brown, H. A., Radio Frequency Electrical Measurements, McGraw-Hill Book Co., Second Edition, 1938, Chapter 6, p. 264.
- Brumbaugh, J. M., and Vance, A. W., A Feedback D-C Meter, Electronics, p. 16, Sept., 1938.
- Brunetti, C., and Harrison, C. W., The Design of a Diode Millivoltmeter, Communications, Vol. 21, No. 1, p. 14, Jan., 1941.
- Builder, G., A Multi-Range Push-Pull Thermionic Voltmeter, Journ. I.E. (Aust.), Vol. 6, No. 11, p. 444, Nov., 1934.

- Builder, G., and Bailey, J. E., Audio Frequency Level Indicators, A.W.A. Tech. Rev., Vol. 3, No. 6, p. 321, Oct., 1938.
- Burgess, R. E., An Improved Circuit for the Direct Current Amplifying Valve of a Valve Voltmeter, Journ. Sci. Instr., Vol. 15, No. 5, p. 171, May, 1938.
- Burroughs, R. E., and Ferguson, J. E., On the Use of the Vacuum Tube Electrometer with Extremely High Input Resistance, Rev. Sci. Instr., Vol. 4, No. 7, p. 406, July, 1933.
- Carter, C. W., A 6H6 A.C.-D.C. Voltmeter, QST, Vol. 23, No. 4, p. 45, April, 1939.
- Chaffee, J. G., The Determination of Dielectric Properties at Very High Frequencies, Proc. I.R.E., Vol. 22, No. 8, p. 1009, Aug., 1934.
- Chinski, G. R., Multiplying the Range of a Vacuum Tube Voltmeter, Electronics, Vol. 11, No. 5, p. 42, May, 1938.
- Chubb, L. W., and Fortescue, C. L., Trans. Am. Inst. Elec. Eng., Vol. 32, p. 739, 1913.
- Chubb, L. W., Trans. Am. Inst. Elec. Eng., Vol. 35, p. 109, 1916.
- Clapp, J. K., A-C Operated Direct-Current Amplifier for Industrial Use, General Radio Experimenter, Vol. 13, No. 9, Feb., 1930.
- Cola, R. de, A dynatron vacuum-tube voltmeter, Electronics, Vol. 2, No. 5, p. 623, May, 1931.
- Colebrook, F. M., The Rectification of Small Radio Frequency Potential Differences by means of Triode Valves, Wireless Eng., Vol. 2, No. 26, p. 865, Nov., 1925, Vol. 2, No. 27, p. 946, Dec., 1925, Vol. 3, No. 28, p. 34, Jan., 1926, Vol. 3, No. 29, p. 90, Feb., 1926.
- Colebrook, F. M., A Valve Voltmeter for Audio Frequencies, Wireless Eng., Vol. 10, No. 117, p. 310, June, 1933.
- Colebrook, F. M., A Valve-Voltmeter with Retroactive Direct-Voltage Amplification, Wireless Eng., Vol. 15, No. 174, p. 138, Mar., 1938.
- Davis, R., Bowdler, G. W., and Standing, W. G., J. Inst. Elec. Eng. (London), Vol. 68, p. 1222, 1930.
- Dearle, R. C., and Matheson, L. A., Exact Compensation for the Effect of A and B Battery Changes when Using the Vacuum Tube as a DC Amplifier, Rev. Sci. Instr., Vol. 1, No. 4, p. 215, April, 1930.
- DuBridge, L. A., Phys. Rev., Vol. 37, p. 392, 1931.
- DuBridge, L. A., and Brown, H., An Improved d.c. Amplifying Circuit, Rev. Sci. Instr., Vol. 4, No. 10, p. 532, Oct., 1933.
- Duncan, D. C., A Self-Powered V.T. Voltmeter of High Sensitivity, QST, Vol. 19, No. 10, p. 42, Oct., 1935.
- Eglin, J. M., J. Opt. Soc. Am. and Rev. Sci. Instr., Vol. 18, p. 393, 1929.
- Ellis, S. B., and Kiehl, S. J., A Practical Vacuum-Tube Circuit for the Measurement of Electromotive Force, Rev. Sci. Instr., Vol. 4, No. 3, p. 131, Mar., 1933.
- Ferris, W. R., Input Resistance of Vacuum Tubes as Ultra-High-Frequency Amplifiers, Proc. I.R.E., Vol. 24, No. 1, p. 82, Jan., 1936.
- Fortescue, C. L., Thermionic Peak Voltmeters for Use at Very High Frequencies, Journ. I.E.E. (London), Vol. 77, p. 429, Sept., 1935.
- Gilbert, J. C. G., Design for a Linear Diode-Condenser Valve Voltmeter, Electronics, Television, S-W World, Vol. 13, No. 152, p. 456, Oct., 1940.

- Gilbert, R. W., A Potentiometric Direct-Current Amplifier and Its Applications, Proc. I.R.E., Vol. 24, No. 9, p. 1239, Sept., 1936.
- Grieg, J., and Wroe, H. N., A Low Reading Mean Voltmeter, Wireless Eng., Vol. 15, No. 183, p. 658, Dec., 1938.
- Griffin, F. T., A General Purpose V.T. Voltmeter with Ray-Tube Indicator, QST, Vol. 20, No. 8, p. 19, Aug., 1936.
- Hayman, W. G., A Compensated Vacuum Tube Voltmeter with Balanced Bridge Output, Wireless Eng., Vol. 7, No. 85, p. 556, Oct., 1930.
- Hoar, T. P., The Use of Triode and Tetrode Valves for the Measurement of Small D.C. Potential Differences, Wireless Eng., Vol. 10, No. 112, p. 19, Jan., 1933.
- King, R., A Screen-Grid Voltmeter Without External Leak, Proc. I.R.E., Vol. 22, No. 6, p. 771, June, 1934.
- King, R., Electrical Measurements at Ultra-High-Frequencies, Proc. I.R.E., Vol. 23, No. 8, p. 885, Aug., 1935.
- Kuebler, R. E., An Improved Volume Indicator, Bell Lab. Rec., Vol. 13, No. 4, p. 122, Dec., 1934.
- Lampkin, G. F., A Simple A-C Voltage Regulator, Electronics, p. 30, Aug., 1937.
- Lane, C. T., D-C Amplifier for Measuring Potentials in Living Organisms, Electronics, p. 31, June, 1937.
- Likel, H. C., A V-T Voltmeter For Audio Frequencies, Electronics, Vol. 13, No. 12, p. 32, Dec., 1940.
- Lorenzen, R., Vacuum-Tube Voltmeters, Service, p. 12, Jan., 1939.
- Lubcke, H. R., Vacuum Tube Voltmeter Design, Proc. I.R.E., Vol. 17, No. 5, p. 864, May, 1929.
- Lutz, C. W., Physik Ztsch., Vol. 13, p. 924, 1912.
- Lyons, W., and Heller, R. E., A Direct Reading Vacuum Tube Millivoltmeter, Electronics, Vol. 12, No. 11, p. 25, Nov., 1939.
- MacDonald, Physics, Vol. 7, p. 265, 1936.
- MacDonald, P. A., and Campbell, E. M., Physics, Vol. 6, p. 211, 1935.
- McLaughlin, J. L., A Linear Electronic Voltmeter, QST, Vol. 16, No. 5, p. 18, May, 1932.
- Marique, J., Notes on the Theory of Diode Rectification, Wireless Eng., Vol. 12, No. 136, p. 17, 1933.
- Medlam, W. B., and Oswald, U. A., The Thermionic Voltmeter, Wireless Eng., Vol. 3, No. 37, p. 589, Oct., 1926, Vol. 3, No. 38, p. 664, Nov., 1926.
- Medlam, W. B., and Oswald, U. A., Further Notes on the Reflex Voltmeter, Wireless Eng., Vol. 5, No. 53, p. 56, Feb., 1928.
- Megaw, E. C. S., Voltage Measurement at Very High Frequencies, Wireless Eng., Vol. 13, No. 149, p. 65, Feb., 1936, Vol. 13, No. 150, p. 135, Mar., 1936, Vol. 13, No. 151, p. 201, Apr., 1936.
- Metcalf, G. F., and Thompson, B. J., Phys. Rev., Vol. 36, p. 1489, 1930.
- Michels, W. C., A Double Vacuum Tube Voltmeter, Rev. Sci. Instr., Vol. 9, No. 1, p. 10, Jan., 1938.
- "Microwave," Valve Voltmeters—A Comprehensive Survey, Television and S-W World, Vol. 10, No. 114, p. 462, Aug., 1937.
- Miles, W. R., Einhoven String Galvanometer Used with a Vacuum Tube Microvoltmeter, Rev. Sci. Instr., Vol. 10, No. 4, p. 134, Apr., 1939.
- Moles, F. J., Gen. Elec. Rev., Vol. 36, p. 156, 1933.

- Moullin, E. B., *Wireless World*, Vol. 10, p. 1, 1922.
- Moullin, E. B., A Direct-Reading Thermionic Voltmeter and Its Applications, *Journ. I.E.E. (London)*, Vol. 61, p. 295, 1923.
- Moullin, E. B., A Thermionic Voltmeter for Measuring the Peak Value and the Mean Value of an Alternating Voltage of any Waveform, *Journ. I.E.E. (London)*, Vol. 66, No. 380, p. 886, Aug., 1928.
- Moullin, E. B., Some Developments of the Thermionic Voltmeter, *Jour. I.E.E. (London)*, Vol. 68, No. 404, p. 1039, Aug., 1930.
- Moullin, E. B., and Turner, L. B., *Jour. I.E.E. (London)*, Vol. 60, p. 706, 1922.
- Nelson, H., A Vacuum Tube Electrometer, *Rev. Sci. Instr.*, Vol. 1, No. 5, p. 281, May, 1930.
- Nergaard, L. S., Electrical Measurements at Wave Lengths Less than Two Meters, *Proc. I.R.E.*, Vol. 24, No. 9, p. 1207, Sept., 1936.
- Hoare, S. C., *Trans. Am. Inst. Elec. Eng.*, Vol. 46, p. 541, 1927.
- Hopper, F. L., Power-Level Indicators For Sound Recording, *Jour. Soc. Mot. Pic. Eng.*, Vol. 29, No. 2, p. 184, Aug., 1937.
- Hughes, E., *J. Sci. Instr.*, Vol. 10, p. 180, 1933.
- Hund, A., *High Frequency Measurements*, McGraw-Hill Book Co., First Edition, Chap. IV, p. 137, 1933.
- Hunt, F. V., A Vacuum-Tube Voltmeter with Logarithmic Response, *Rev. Sci. Instr.*, Vol. 4, No. 12, p. 672, Dec., 1933.
- James, E. G., and Polgreen, G. R., Instruments Incorporating Thermionic Valves and Their Characteristics, *Journ. I.E.E. (London)*, Vol. 85, No. 512, p. 242, Aug., 1939.
- Jansky, C. M., and Feldman, C. B., *J. Am. Inst. Elec. Eng.*, Vol. 47, p. 126, 1928.
- Johnson, E. A., and Neitzert, C., The Measurement of Small Alternating Voltages at Audiofrequencies, *Rev. Sci. Instr.*, Vol. 5, No. 5, p. 196, May, 1934.
- Kauter, W., Vacuum Tube Voltmeter Capable of Standing Heavy Overloads, *El. Nachr. Tech.*, Vol. 14, p. 45, 1937. (Summarized in *Electronics*, p. 48, June, 1937.)
- King, R., A Screen-Grid Voltmeter and Its Application as a Resonance Indicator, *Proc. I.R.E.*, Vol. 18, No. 8, p. 1388, Aug., 1930.
- Murray, C., Thermocouple used in low-voltage tube voltmeter, *Electronics*, Vol. 8, No. 6, p. 190, June, 1935.
- Nergaard, L. S., A Survey of Ultra-High-Frequency Measurements, *R.C.A. Review*, Vol. 3, No. 2, p. 156, Oct., 1938.
- Nottingham, W. B., Measurement of Small D.C. Potentials and Currents in High Resistance Circuits by Using Vacuum Tubes, *Jour. Franklin Inst.*, Vol. 209, No. 3, p. 287, March, 1930.
- Paine, R. C., A Self-Checking Vacuum Tube Voltmeter, *Electronics*, Vol. 12, No. 6, p. 60, June, 1939.
- Payne, E. L., and Story, J. G., A Portable Programme Meter, *Wireless Eng.*, Vol. 12, No. 146, p. 588, Nov., 1935.
- Penick, D. B., Direct-Current Amplifier for Use with the Electrometer Tube, *Rev. Sci. Instr.*, Vol. 6, No. 4, p. 115, April, 1935.
- Peterson, E., U. S. Patent 1,586,553; 1926.

- Pierce, J. R., A Proposed Wattmeter Using Multielectrode Tubes, Proc. I.R.E., Vol. 24, No. 4, p. 577, April, 1936.
- Pollard, R. E., A New Idea in V.T. Voltmeter Design, QST, Vol. 23, No. 3, p. 56, Mar., 1939.
- Potts, J. H., V-T Voltmeters, Radio Service-Dealer, Vol. 1, No. 5, p. 9, Aug., 1940.
- Preisman, A., High resistance measurement with vacuum tubes, Electronics, Vol. 8, No. 7, p. 214, July, 1935.
- Ragazzini, J. R., and Boymel, B. R., A Square-Law Vacuum-Tube Voltmeter, Rev. of Sci. Instr., Vol. 11, No. 10, p. 312, Oct., 1940.
- Razek, J., and Mulder, P. J., J. Opt. Soc. Am. and Rev. Sci. Instr., Vol. 18, p. 460, 1929.
- RCA Application Note No. 47, Application Note on the Use of the 954 as a Vacuum-Tube Voltmeter, May 20, 1935.
- Reed, M., The Problem of "Turn-over," Wireless Eng., Vol. 6, No. 69, p. 310, June, 1929.
- Reed, M., Some Applications of an A.C. Valve Bridge, Wireless Eng. and Experimental Wireless, Vol. 11, No. 127, p. 175, Apr., 1934.
- Reich, H. J., Marvin, G. S., and Stoll, K. A., Vacuum tube voltmeter of high sensitivity, Electronics, Vol. 3, No. 3, p. 109, Sept., 1931.
- Reich, H. J., Theory and Application of Electron Tubes, McGraw-Hill, First Edition, Chap. 15, p. 555, 1939.
- Reid, D. G., A Thermionic Voltmeter with a Linear Law, Journ. Sci. Instr., Vol. 15, No. 8, p. 261, Aug., 1938.
- Reynor, J. H., Sensitive Valve Voltmeter, Wireless World, Vol. 40, No. 11, p. 246, Mar. 12, 1937. (Correction p. 285, Mar. 19, 1937.)
- Rose, G. M., A Method for Measuring Very High Values of Resistance, Rev. Sci. Instr., Vol. 2, No. 12, p. 810, Dec., 1931.
- Rothchild, Lord, A Thermionic Voltmeter for Low Voltages, Journ. Sci. Instr., Vol. 14, No. 11, p. 373, Nov., 1937.
- Ruiz, J. J., A Peak Voltmeter, Rev. Sci. Instr., Vol. 6, No. 6, p. 169, June, 1935.
- Salzberg, B., and Burnside, D. G., Recent Developments in Miniature Tubes, Proc. I.R.E., Vol. 23, No. 10, p. 1142, Oct., 1935.
- Sayce, L. A., An Experimenter's Wireless Laboratory, Experimental Wireless and The Wireless Eng., Vol. 3, No. 30, p. 144, Mar., 1926, Vol. 3, No. 31, p. 243, April, 1926.
- Scott, H. H., and Packard, L. E., The Sound-Level Meter in the Motion Picture Industry, Jour. Soc. Mot. Pic. Eng., Vol. 30, No. 4, p. 458, Apr., 1938.
- Sharp, C. H., and Doyle, E. D., Trans. Am. Inst. Elec. Eng., Vol. 35, p. 99, 1916.
- Sinclair, D. B., The Type 726-A Vacuum-Tube Voltmeter As a Radio-Frequency Ammeter, General Radio Experimenter, Vol. 13, No. 3-4, Aug.-Sept., 1938.
- Sinclair, D. B., A Voltage Multiplier for Use with the Vacuum-Tube Voltmeter at Radio Frequencies, General Radio Experimenter, Vol. 14, No. 12, May, 1940.
- Smyth, C. N., A Multi-range Mains Operated Valve Voltmeter, Wireless Eng., Vol. 10, No. 114, p. 134, Mar., 1933.

- Sohon, H., Supervisory and Control Equipment for Audio-Frequency Amplifiers, Proc. I.R.E., Vol. 21, No. 2, p. 228, Feb., 1933. (Discussion in Proc. I.R.E., p. 1497, Oct., 1933.)
- Somers, R. M., An Improvement in Vacuum Tube Voltmeters, Proc. I.R.E., Vol. 21, No. 1, p. 56, Jan., 1933.
- Starr, A. T., Proc. Phys. Soc. London, Vol. 46, p. 35, 1934.
- Starr, A. T., A Trigger Peak Voltmeter Using "Hard" Valves, Wireless Eng., Vol. 12, No. 146, p. 601, Nov., 1935.
- Taylor, J., J. Sci. Instr., Vol. 3, p. 113, 1925.
- Taylor, D. P., Transmitter Measurements, Wireless World, Vol. 44, No. 2, p. 513, June 1, 1939.
- Terman, F. E., The Inverted Vacuum Tube, A Voltage-Reducing Power Amplifier, Proc. I.R.E., Vol. 16, No. 4, p. 447, April, 1928.
- Terman, F. E., Measurements in Radio Engineering (First edition), McGraw-Hill Book Co., p. 18, 1935.
- Tulauskas, L., A multi-range vacuum tube voltmeter, Electronics, Vol. 1, No. 4, p. 170, July, 1930.
- Turner, L. A., On Balanced d.c. Amplifying Circuits, Rev. Sci. Instr., Vol. 4, No. 12, p. 665, Dec., 1933.
- Turner, L. A., and Siegelin, C. O., An Improved Balanced Circuit for Use with Electrometer Tubes, Rev. Sci. Instr., Vol. 4, No. 8, p. 429, August, 1933.
- Tuttle, W. N., Type 726-A Vacuum-Tube Voltmeter, General Radio Experimenter, Vol. 11, No. 12, May, 1937.
- Usselman, G. L., A V-T Voltmeter for Coaxial Line Measurements, Electronics, Vol. 13, No. 7, p. 32, July, 1940.
- Vance, A. W., An Improved Vacuum Tube Microammeter, Review of Sci. Instr., Vol. 7, No. 12, p. 489, Dec., 1936.
- Van der Bijl, The Thermionic Vacuum Tube (First edition), Chapter 10, pp. 367, 369, McGraw-Hill Book Co., 1920.
- Vollrath, R. E., A Duo-Triode Bridge Voltmeter, Rev. Sci. Instr., Vol. 10, No. 12, p. 361, Dec., 1939. (Summarized in Electronics, p. 62, Feb., 1940.)
- Wagner, T. B., A Thermionic-Tube Measuring Instrument, Electrical Engineering, Vol. 53, No. 12, p. 1621, Dec., 1934.
- Waller, L. C., Amateur Applications of the "Magic Eye," QST, Vol. 20, No. 10, p. 35, Oct., 1936, Vol. 20, No. 11, p. 23, Nov., 1936.
- Waller, L. C., Applications of Visual-Indicator Tubes, R.C.A. Review, Vol. 1, No. 3, p. 111, Jan., 1937.
- Warren, G. W., The Electrometer Triode and Its Applications, G.E.C. Jour., Vol. 6, p. 1, 1935.
- Williams, F. C., A New Modulation Meter, Wireless Eng., Vol. 15, No. 176, p. 257, May, 1938.
- Winch, G. T., J. Sci. Instr., Vol. 6, p. 376, 1929.
- Wold, P. I., U. S. Patent 1,232,879; 1916-1917.
- Wolff, I., Alternating-Current Measuring Instruments as Discriminators Against Harmonics, Proc. I.R.E., Vol. 19, No. 4, p. 647, April, 1931.
- Wynn-Williams, C. E., Phil. Mag., Vol. 6, p. 324, 1928.
- Wynn-Williams, C. E., Proc. Cambridge Phil. Soc., Vol. 23, p. 810, 1927.

INDEX

- A-c v-t voltmeter
 - basic operation, 6
- Accuracy
 - a-c v-t voltmeter, 134
 - compensation for variations, 135
 - d-c v-t voltmeter, 110
 - high frequency error reduction, 136
 - slide-back correction curve, 151
- Advantages, 2
- Amplifier, degenerative d-c, 116, 118, 130
- Amplifier operation check, 158
- Amplifier stage measurements, 157
- Applications of v-t voltmeters, 157
- Audio-frequency v-t voltmeter, 87
 - high-sensitivity type, 91
 - logarithmic types, 96
 - simple type, 88
- Average reading v-t voltmeter, 17

- Balanced v-t voltmeter, 59, 118, 121
- Balancing circuits, 12, 55
 - cathode balancing, 58
 - two-tube bridge circuit, 59
 - using voltage divider, 57
- Bucking circuits—see Balancing circuits
- Bypassing, 54, 60, 137

- Calibration, 12
 - accuracy, 134
 - a-c calibration set-up, 148
 - at ultra-high frequencies, 152
 - checking decibel calibration, 155
 - checking logarithmic calibration, 155
 - choice of standards, 146
 - comparison voltmeter, 153
 - contact potential effect in diode vtm, 25, 26
 - d-c v-t voltmeter, 155
 - decade voltage divider, 149
 - general precautions, 147
 - permanence, 134
 - 60-cycle calibration, 149
 - use of tube-tester transformer, 147
 - use of variable ratio transformer, 148
 - use of Variac, 148
 - waveform considerations, 150
- Capacitance measurement, 159, 160
- Center-zero, 111
 - for galvanometer applications, 115
- Complex waves, 7, 150
- Contact potential
 - a-c vtm, 140
 - diode vtm, 25, 26
 - d-c vtm, 109, 137
- Current measurement, 129
 - a-c current measurement, 162
 - d-c current measurement, 163
 - ultra-sensitive, 129, 132

- D-c v-t voltmeter
 - balanced push-pull, 118
 - calibration, 155
 - center-zero, 111
 - high input resistance type, 128
 - measurement of grid current, 156
 - measurement of input resistance, 156
 - RCA Junior VoltOhmyst, 121
 - single-tube degenerative, 116
 - slide-back, triode, 65
 - triode, slide-back, 65
- Design and construction, 133
- Decibel scale, 98
- Diode characteristic, 13
- Diode rectifier operation, 15
- Diode v-t voltmeters, 13
 - application, 17
 - contact potential, 25, 26
 - high voltage, peak reading, shunt type, 22
 - peak reading, series type, 17
 - peak reading, shunt type, 19, 21, 22
 - slide-back type for negative peak voltages, 29
 - slide-back type for positive peak voltages, 27
 - slide-back type for trough voltages, 30
 - time constant, 23

- Frequency range, 133
 - bypassing, 137

- diode, peak reading, series type, 19
- diode, peak reading, shunt type, 20
- diode v-t voltmeter, 17
- triode, half-wave square-law, 35
- v-t voltmeters, 3
- Fundamentals of vtvm, 1
- General Radio 726-A Voltmeter, 77
- Grid-circuit of v-t voltmeters, 140
- Grid current in d-c v-t voltmeter, 109
 - measurement, 156
 - see Contact potential
- Guard terminal, 127
- Hickok Model 110 VTVM, 166
- High-frequency error, 136
- Impedance measurement at low frequency, 159
- Inductance measurement, 159, 160
- Input impedance, 133
 - diode peak reading vtvm, series type, 19
 - diode v-t voltmeter, 17
 - d-c v-t voltmeter, 109
 - high input impedance vtvm, 128
 - measurement of, 152
 - slide-back, triode, 63
 - triode, grid-rectification, 47
 - triode, half-wave square law, 35
 - triode, self-bias, 52
 - triode, slide-back, 63
- Isolating resistor, 113
- Leakage reduction, 141
- Logarithmic milliammeter, 100
- Logarithmic scale, 97, 98
- Logarithmic v-t voltmeter, 96
 - amplifier-rectifier type, 105
 - controlled-amplifier type, 102
 - types, 99
 - using logarithmic milliammeter, 101
- Meters for v-t voltmeters, 138
- Microammeter, v-t, 130
 - multi-range, 131
 - using inverse feedback, 131
- Milliammeter, logarithmic, 100
- Modulation indicator, 162
- Multiplier
 - for a-c vtvm, 83, 143
 - for d-c vtvm, 145
- Negative peak vtvm
 - phase reverser, 163
 - slide-back, diode, 29
- Ohmmeter, v-t, 122
 - direct reading, 123
 - guard terminal, 127
 - high resistance measurement, 128
 - leakage reduction, 141
 - measurement of grid current, 156
 - measurement of input resistance, 156
 - slide-back type, 128
 - with external voltage supply, 125
- Overload, 134
- Peak v-t voltmeter
 - amplifier, slide-back, 68
 - diode, series type, 17
 - diode, shunt type, 19, 21, 22
 - diode, slide-back, 27, 29
 - rectifier-amplifier, 70
 - space charge, slide-back, 66
 - triode, plate rectification, 44
 - triode, slide-back, 64
- Power supply measurement, 159
- Probe, 82, 113
- Power supply, 142
 - regulated voltage supply, 143
- Radio receiver operation check, 158
- RCA Junior VoltOhmyst, 121
- Rectifier-amplifier v-t voltmeters, 70
 - diode rectifier, 71
 - General Radio 726-A voltmeter, 77
 - rectifier, degenerative amplifier, 76
 - reflex rectifier, 72
 - voltage-divider, 74
- Resistance measurement
 - d-c, 122

- r-f, 161
 - see ohmmeter, v-t
- Resistors in v-t voltmeters, 139
- Rms v-t voltmeter
 - see square-law vtvm
- Ruggedness, 3

- Signal tracing, 158
- Sine wave, 7
 - average value, 9
 - peak value, 8
 - rms value, 10
- Slide-back vtvm, 61
 - amplifier type, 68
 - diode vtvm for negative peak voltages, 29
 - diode vtvm for positive peak voltages, 27
 - diode vtvm for trough voltages, 30
 - error, 62
 - for d-c measurements, 110
 - space-charge type, 66
 - triode slide-back voltmeter, 61
- Square-law
 - ideal square-law vtvm, 40
 - operating point, 42
 - pentode, 138
 - scale distribution, 41
 - triode, full-wave vtvm, 38, 163
 - triode, half-wave vtvm, 33
 - use of log-log paper, 154

- Stability, 134
- Supreme Model 549 VTVM, 168

- Television amplifier v-t voltmeter, 93
- Testing vtvm, 146
- Time constant
 - definition, 23
 - diode peak vtvm, 23, 24
- Transformer turn ratio measurement, 158
- Triode vtvm, 32
- Triplet Model 1252 VTVM, 167
- Trough vtvm
 - slide-back, diode, 30
 - slide-back, triode, 64
- Tube selection, 137
- Tuned v-t voltmeter, 81
- Turnover, 150

- Ultra-high frequency vtvm, 53, 79, 136, 152

- Vacuum tubes, 136, 137
- Voltage range, 133
 - extension of a-c types, 143
 - extension of d-c types, 145
- VoltOhmyst, RCA Junior, 121

- Wave analyzer, 163
- Waveform, 7, 33, 38, 134, 150
- Weston Model 669 VTVM, 169